

Robotic Arm Control Using Arduino

Rajashekar K¹, Hanumantha Reddy², Ruksar Begum T K³, Shaheena Begum⁴, Syeda Ziya Fathima⁵, Saba Kauser⁶

^{1, 2} Assistant Professor, Department of Electrical & Electronics Engineering

^{3,4,5,6} B.E Student, Department of Electrical & Electronics Engineering
Rao Bahadur Y. Mahabaleswarappa Engineering College

Ballari, Karnataka, India.

Abstract – Today technology is developing in the same direction in line with rapidly increasing human needs. The work done to meet these needs makes life easier every day, and these studies are concentrated in robotic arm studies. Robot arm works with an outside user or by performing predetermined commands. Nowadays, the most developed field of robot arms in every field is the industry and medicine sector. Designed and realized in the project, the robot arm has the ability to move in 4 axis direction with 5 servomotors. Thanks to the holder, you can take the desired material from one place and carry it to another place, and also mix it with the material it receives. While doing this, robot control is provided by connecting to the android application via Bluetooth module connected to Arduino Nano microcontroller.

Keywords: Arduino , Robotic.

I. INTRODUCTION

The term robot comes from the Czech word ‘robota’, generally translated as “forced labor”, this describes the majority of robots fairly well. Most robots in this world are designed for heavy, difficult to manufacture in work. They handle tasks that are difficulty, dangerous or boring to human beings. The most common robot is the robotic arm. This robotic arm is type of mechanical model arm, it is usually programmed, like of a human arm may be the sum total of mechanism or may be part of more complex robot. The links of such a manipulator are connected by joints allowing either rotational motion (such as in a articulated robot) or linear displacement.

An industrial arm with six joints similarly to a human arm it has equivalent of a shoulder, elbow and a wrist. Typically, the shoulder is mounted on a stationary base structure rather than to a movable body. This type of robot has six degree of freedom, meaning it can pivot in six different ways. A human arm by comparison has seven degree freedom.

Like as we have our arm whose job is to move your hand from place to place. Similarly job of robotic arms is to move an object from one place to other that is what a pick and place robotic arm. Industrial robots are designed to do exactly in a controlled environment, over and over again.

In this project, Arduino Nano microcontroller written in java language is programmed and servo motor control is provided. Thus, it is possible to perform the desired operations by means of elements located on the arduino without any circuit construction other than the circuit where the servo motor inputs are located. For the mechanical part, the robot arm is drawn with solid works program and dimensions of the

Circuit construction other than the circuit where the servo motor inputs are located. For the mechanical part, robot arm are

specified. A 5v power supply is also preferred for the robot to work.

II. LITERATURE SURVEY

Various researches have been made by different researches for developing this project. However, they serve a different application and have different technologies implemented. Some of those papers are mentioned below stating their technology and application.

Jorge Kazacos Winter [2] has developed android controlled robot automation. Main aim of his project was the transfer of information wirelessly between a Smartphone and the robot and developing the robot and its communication system underneath a low price and open source philosophy. He used 3D design technique to style the structure of the robot with the facilitation of parametrical modeling software. The style, when fed to the 3D printer can print the parts of the robot in a layered manner one by one and can then use these parts to assemble the robot simply. He has used arduino micro-controller and Wi-Fi technology in this robot.

M. Selvam [4] in his paper has design to develop a robotic system which has a wireless camera attached to the surveillance. Bluetooth was implemented in his project for providing connection between robot and smart phone. Wireless night vision camera was used for providing the robot surveillance. The video which is recorded by camera is then transmitted to TV unit through radio frequency signal. He used 8051 micro-controllers for the robotic unit.

Ranjith Kumar Goud and B. Santosh Kumar [3] have invented a pick and drop robot. They wanted it to be used for diffusing a bomb remotely with safety. For the robotic arm, they used a pair of motors and another pair as the wheels of the robot for controlling the movement. Connectivity is established using Bluetooth. The micro-controller used is LPC2148. They had also attached wireless camera for remote surveillance. They have worked on this project mainly for industrial and military applications.

Arpit Sharma, Ritesh Verma, Saurabh Gupta, Sukhdeep Kaur Bhatia [9] has configured an android Smartphone which can control a robot via Bluetooth technology. The phone uses motion sensors and records the gestures sent via an android mobile phone. It also has an inbuilt accelerometer and Bluetooth module for controlling the movements of a robot.

III.OBJECTIVES

The important objectives that are associated in installing of robotic systems in industries are; . 1) Saving of manpower.

Improved quality and efficiency.

Save human's life.

Ability to work in any hostile environment.

IV. BLOCK DIAGRAM

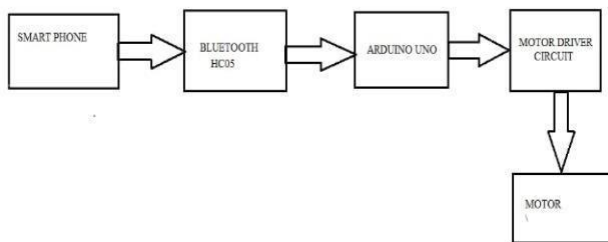

Fig 1: Block diagram of robotic arm using arduino

METHADODOLOGY

The robot has been design to mimic the movement of a human arm. This section will present a full description of the hardware of the robot design and it is divided into two main sections: mechanical and electrical design.

Mechanical Design: The robot had a round base with a diameter of 22cm and the height of 15cm. the robot degree-of-freedom mechanism is directly powered by servo motors. Acrylic is used as the robot base because it is easy to be formed, cheap, strong and can bear the motor weight and movement. The robotic arm is constructed using servo brackets that are made of aluminums because it is light weight but stiff to mimic the bone structure of a human arm. The robot gripper is also made of aluminum because of the same reason as the main robot arm structure.

Electrical Design: The block diagram is as shown above. Basically, this robot has 5 outputs which consist of the robot base, the robot shoulder, the robot elbow, the robot wrist, and the robot gripper.

VI. PROBLEM STATEMENT

In the high voltage engineering lab, during the sphere gap arrangement experiment the neutral point has to be grounded after the flash over occur with the help of electrode rod which is a potential dangerous work. In order to avoid this problem that is instead of manual grounding we are using

VII. CIRCUIT DIAGRAM

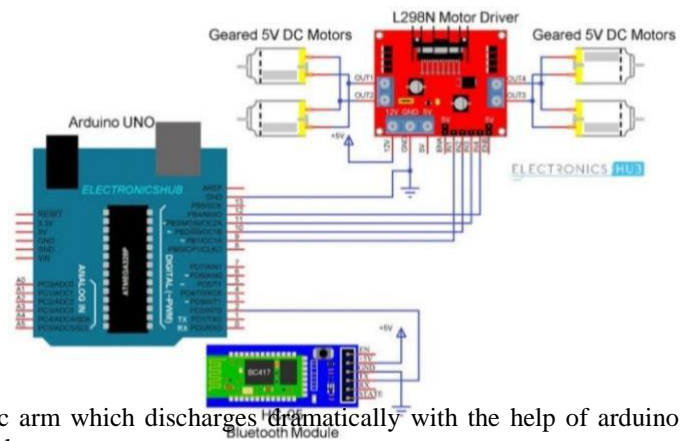

robotic arm which discharges dramatically with the help of arduino technology.

Fig 2: Circuit diagram of robotic arm using arduino

Robotic arm: A robotic arm is a type of mechanical arm, usually programmable with similar functions to a human arm; the arm may be sum total of the mechanism or may be part of a more complex robot. The links of such a manipulator are connected by joints allowing either rotational motion or translational displacement. The links of the manipulator can be considered to form a kinematic chain. The terminus of the kinematic chain of the manipulator is called end-effector and it is analogous to the human hand. The end-effector, or robotic hand, can be designed to perform any desired tasks such as welding, gripping, spinning etc., depending on the application.

Servomotors: Servo; detects the operation error of a mechanism, provides feedback and corrects faults. The servo motor can have alternating current (AC), direct current (DC) or stepper motors. In addition to these, there are drive and control circuits. Servo motors are the kinds of motors that can fulfill the commands we want. They can operate steadily even at very small or very large speeds. The large moment can be obtained from the small size.

Servo motors are used in control systems such as fast operation, excessive axis movement, condition control and so on. Servo motors are the last control element of a mechanism. They are highly sensitive and servo motors are used in conjunction with electronic or programmable circuits. These engines are divided into AC and DC. When the AC servo motors are brushless type motors, the servo motors brush. Servo motors are mostly three cables. These are a red cable for power, black for grounding and yellow cables for control (data, data). One of the servo motors used in the production phase of the project.

Power Supply: It is basically consist of transformer, rectifier filter and regulator circuits. Power supply units (PSU) are used in computers. Amateur radio transmitters and receivers and all other electronic equipments that used dc voltage as an input. A power supply takes the ac from the ac source and the step down transformer which is connected to ac source decrease the voltage from 230v to 12v ac, and then it is converted to unregulated dc by rectifier unit. This rectified unregulated dc voltage is filtered by filter capacitor and regulated by electronic regulated i.e., ic7812, ic7809, ic7805.

Manipulator: The manipulator is the entire mechanism of the robot that provides movement of any degree of freedom. The joints to the robotic manipulator are the movable components, which enables relative motion between adjoining links. Further they consist of base, arm and gripper.

Arduino UNO: Although microcontroller type PIC is usually used in programming and software fields, arduino UNO is an open-source microcontroller board based on the microchip ATmega328P microcontroller and developed by arduino.cc. The board is equipped with sets of digital and analog input/output pins that may be interfaced to various expansion boards and other circuits. Arduino has become very popular in the world in recent times. It is based on arduino's past wiring and processing projects. Processing is written for non-programming users. Arduino wiring is produced on the basis of programming language.

HC-05 Bluetooth: This module is used to communicate between two microcontrollers like arduino or communicate with any device via Bluetooth. This module communicates with the help of USART at 9600 baud rate. The HC-05 has two operating modes, 1 is the data mode in which it can send and receive data from other Bluetooth devices and the other is AT command mode where the default device setting can be changed.

L298N Motor Driver: The L298N is a dual H-bridge motor driver which allows speed and direction control of two dc motors at the same time. The module can drive dc motors that have voltages between 5 and 35 volts with a peak current upto 2amps. The driver module can drive two motors. The enable terminals ENA and ENB are effective at high level. ENA and ENB pins are speed control pins for motor A and motor B, the enable A pin must be high to turn on the motor to drive motor to A direction say, clockwise, the pin input 1 must be high while pin input 2 must be low, to drive a motor to a direction say counter clockwise the pin input 1 must be low while pin input 2 must be high. Although we need to do is to apply signal to input and make motor to certain direction.

VIII. ADVANTAGES

Automatic grounding of high voltage system.
Retrieving suspicious objects without endangering humans.
iii) Dig trenches.

IX. APPLICATIONS

Instead of manual grounding of high voltage system which is dangerous so we are going for automatic grounding of high voltage system by robotic arm.

X. EXPECTED RESULT

“Manual Setting” for manual control of robotic arm.

ii) “Automatic function” for pre-programmed robotic arm movements.

The arduino controlled via Bluetooth controlled robotic arm as shown has been developed and will be applied in real world application. It can mimic the movement of a human arm such as pick and place and maneuver around.

ACKNOWLEDGEMENT

We would like to extend our sincere thanks to **Principal & HOD EEE of the RYMEC** institution, we would like to express our deepest appreciation to **Mr. Rajashakar K** for encouraging our project proposal for paper publishing work, we extremely grateful for **Institute lecturers**, we would also like to extend our deepest gratitude to **friends, & family members** for useful discussions.

References:-

- WMHW Kadir, RE Samin, BSK Ibrahim. Internet controlled a robotic arm. Procedia Engineering. 2012.
- AM Al-Busaidi, Development of an educational environment for online control of a biped robot using MATLAB and Arduino, (MECHATRONICS), 9th France-Japan.2012.
- Nakamura, Y. (1991). Advanced Robotics: Redundancy and Optimization. Addison-Wesley, Boston.
- Ceccarelli, M. (2004). Fundamentals of Mechanics of Robotic Manipulation, Kluwer, Dordrecht.
- Surbhi Verma, Android App Controlled Bluetooth Robot. International Journal of Computer Applications (0975-8887).
- Afzal, Waseem. (2017). Gesture Control Robotic Arm Using Flex Sensor. Applied and Computational Mathematics. 6. 171. 10.11648/j.acm.20170604.12.
- Jayabala, Pradeep. (2016). Design and Implementation of Gesture Controlled Robotic Arm for Industrial Applications. International Journal of Scientific Research. 3. 202-209.
- MAK Yusoff, RE Samin, mobile robotic arm. Procedia Engineering. 2012.
- HS Juang, KY Lurr. Design and control of a two-wheel self-balancing robot using the Arduino microcontroller board. Control and Automation (ICCA), 2013.
- Gosselin, C.M. (1992). The optimum design of robotic manipulators using dexterity indices. Robotics and autonomous systems, vol. 9, p. 213-226.