

Materials and analyses imposed in helicopter rotor blade vibrations: Review

¹P. A. Patil, ²D. D. Shinde, ³Mikhail K. Bhavsar

¹MTech Student, ²Associate Professor, ³Professor

¹Department of Design,

¹Sandip University, Nashik, Maharashtra, India.

Abstract: The aerospace industries focus on the vibration analysis of the components; it causes malfunction of the system and, in extreme condition, causes catastrophic failure. The helicopter comprises several issues primarily caused due to vibrations. In the vibrations issue, the failure due to resonance phenomena is a significant concern. The other problems caused due to vibration are fatigue failure, operator discomfort, components, uneven wear, and poor stealth performance. The primary source of vibration in a helicopter is the primary rotor system (i.e., rotor blade). The resonance depends on the natural frequency of the material, and natural frequency depends on material stiffness and mass. In order to reduce the occurrence of resonance, the rotor blade must be designed with low mass and high stiffness principle. The composite materials comprise the high strength to weight ratios, which makes them ideal for application in the rotor blade. This paper provides a review of the materials applied and vibration analyses utilized for the helicopter rotor blade. The purpose of vibration analyses is to measure or evaluate the vibrational characteristics of any components, so the methods applied for it are included in the review. The methods for vibration analysis, such as modal analysis, operational modal analysis (O.M.A.), Fast Fourier Transform (FFT) analysis, Spectral Power Density (S.P.A.) Analysis, spectrum analysis, and other experimental analyses are studied for the review. It was discovered that the composite materials consist of higher natural frequencies than the metal alloys, and the modal analysis was the most utilized method for vibration analysis.

Index Terms - Helicopter rotor blade, rotor blade material, vibration analyses.

I. INTRODUCTION

The vibrations in the helicopter is a major interest among the scientists from the beginning of its operation in aerospace industries. The vibrations adversely affect the integrity and life of the components of the helicopter. It causes major issues, such as a reduction in rotor blade structural integrity, components life, instrument accuracy, structural member strength, operator comfort, and the stealth in radar (noise due to vibrations). Also, vibrations in other systems primarily caused due to imbalance of rotating masses and insufficient lubrication. In the case of the helicopter, the primary cause of vibrations is the main rotor blades (which are considered as high-speed rotating masses). The aerodynamic conditions, as turbulence in the air and air density change during hovering or forward flight conditions, are also the causes of vibrations. The vibrations in a helicopter may cause the malfunction of the control system or of the rotor system, which affect into catastrophic failure. There are several kinds of research ongoing for detection and reduction of vibrations, but it is impossible to eliminate them fully. The vibrations in the rotor blade primarily depend on the material characteristics and geometry design of the blade. Several composites and alloy materials are deployed in the rotor blade research, and for detection and reduction of vibrations, several analyses are also deployed. In this paper, the materials deployment and the analyses utilized for vibration analysis are studied through a literature survey. This paper executes a review of the vibration analyses and material deployments in the helicopter rotor blade.

The rotor blade of the helicopter undergoes several types of unwanted vibrations, due to its operating conditions. This necessitates the need to consider the vibration analysis in its design process. The factors ruling the amplitude and frequency of the vibration are the applied excitation and the response to such excitations [1]. The dynamic stresses and strains cause fatigue and, apparently, the failure of the rotor system, which is generated due to vibrations [1][2]. The fretting corrosion and noise generation are also the potential causes of vibration, which affect the function and life of the rotor blade. The vibration analysis comprises the evaluation of natural frequencies and response to the excitation [1]. If the blade is excited at its natural frequency, the resonance phenomena occur, which increases the amplitude of vibrations, noise levels, dynamic stresses, and, lastly, failure of the system [2]. For avoiding resonance, the expected frequency range of natural frequencies must be evaluated and avoided to be excited. The natural frequency depends on the design and material properties of the rotor blade. The natural angular frequency defined as the square root of the ratio of stiffness to the mass of the material. The natural frequency is the ratio of natural angular frequency to 2π .

Dimitrius, Mirko, et al. have carried out vibration analysis through three stages, which are as following [3]:

- Prepare a mathematical model of the system which is to be analyzed.
- Further, construct the equations of motion.
- And finally, calculate the response to specific excitation.

They have computed the natural frequencies and mode shapes through solving the Eigen Value problem. Vibration analysis is applied to a modified Gazelle helicopter blade, which consists of Nomex honeycomb structure core, carbon fiber cross-ply wrap, stainless steel tube, carbon fiber inner wrap, glass fiber spar, and carbon fiber cross-ply skin. The Fig.No.1 shows the modified Gazelle helicopter blade structure [1][4]. The equation of motion for natural frequencies and normal modes is reduced in the analytic solution [5]. The transformation methods and tracking methods, which are eigenvalue methods, were analyzed for accounting the most efficient method [6][7]. The transformation methods consist Givens method, Householder method, modified Givens, and Householder method. The tracking methods consist inverse power method, and Sturm modified inverse power method [6][7]. In modeling of the blade, the eight nodal hexahedron elements were utilized in the sandwich structure's meshing, and for plate elements, the Kirchoff thin plate theory is applied. In modeling further, the honeycomb core model single hexagon cell, the stress-strain analysis, was performed [8]. In face sheets modeling, they considered them as composite lamina with continuous fiber, and their stress-strain relations were expressed [9]. Further, in modeling, the adhesive model was prepared. The mounting of facesheets on honeycomb core is bonded and considered as elastoplastic adhesive behavior [10]. Considering all the models, modal analysis

was performed on the blade. It was concluded that the most efficient method was the Lanczos method. As the composite honeycomb core comprises many degrees of freedom, it becomes essential to apply equivalent plate theories [1].

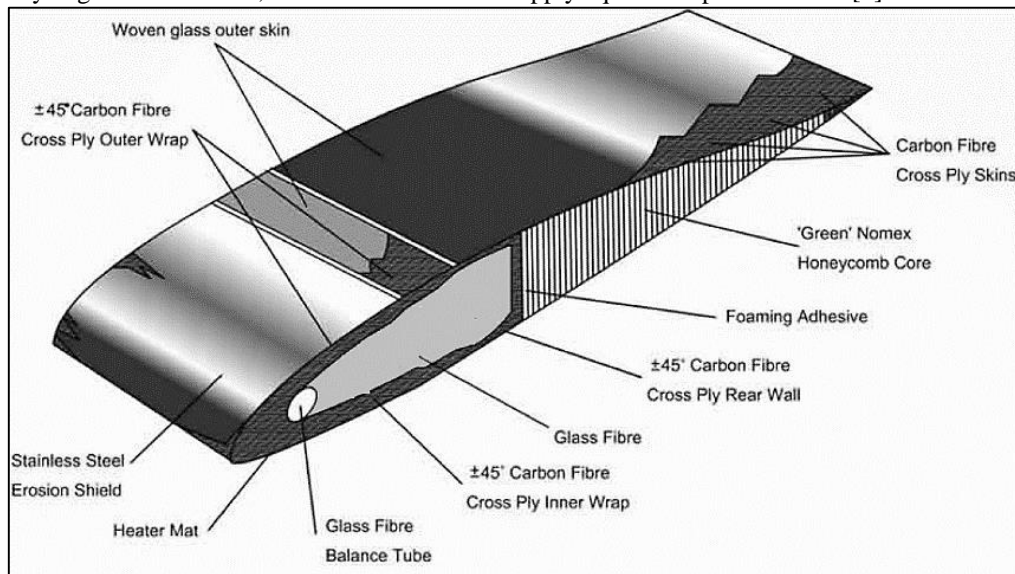

Figure 1. The Modified Gazelle Helicopter Blade Structure [1]

Sebastian M. Z. has performed modal analysis on a helicopter blade, for evaluating the natural frequencies and their occurrences. Due to the availability of flight phenomena simulation instruments and advanced fabrications technology, the components such as fuselage, blades, rotors, engines, and other several components were produced with higher performance and reliability. In order to reduce fatigue effects, it is essential to reduce vibration levels. Reduction in vibration level also results in increasing the components of life. The rotor and blade vibration levels are more effective than fuselage in case of losing control and total destruction of the helicopter [11]. The parameters such as crew efficiency, safety of operation, passenger comfort, onboard electronic and mechanical components, and fatigue life of structural components, are taken into account for finalizing the acceptance level of vibrations [12]. The helicopter rotor undergoes the Coriolis, centrifugal forces, and axial tension, during the different flight conditions [11]. The flutter and divergence of the blade are the major aspects of increasing vibration level. The instability state and in case of blade oscillatory motion at a certain speed and frequency is known as flutter. The divergence of the blade is also known as pitch-flap instability of the blade [13][14]. The most important damping systems are the DAVI (dynamic anti-resonant vibration isolator) and supple platinum [11]. DAVI is situated between the transmission box and the hull [12][14]. The supple platinum is situated in between the transmission box and the mechanical board [15]. The mechanical strength, profile dimensional precision, corrosion resistance, static and dynamic balancing, and rigidity in flapping, feathering, and lagging movements of the blade, are the characteristics that must be considered while designing a helicopter blade. The modeling and modal analysis in this paper was carried out in ANSYS 15 Workbench. The profile of the blade selected was SIKORSKY SC1095 with particular characteristics. The modeling parameter was 600 mm chord, rectangular shape, length of 6.25 m, and skin thickness 0.6 mm. Mechanical characteristics of carbon fiber were applied as 70 GPa Young's modulus (at 0° and 90°), 0.10 Poisson's ratio, and 1.60 g Cm⁻³ density. Modal natural frequencies were evaluated for the first six modes. The frequency-domain discovered is 2 Hz to 13 Hz. It is concluded that the results were under the expected limit, so the blade is safe to put into operation [11]. The rotor blades main movements are shown in Fig. No. 2. [11].

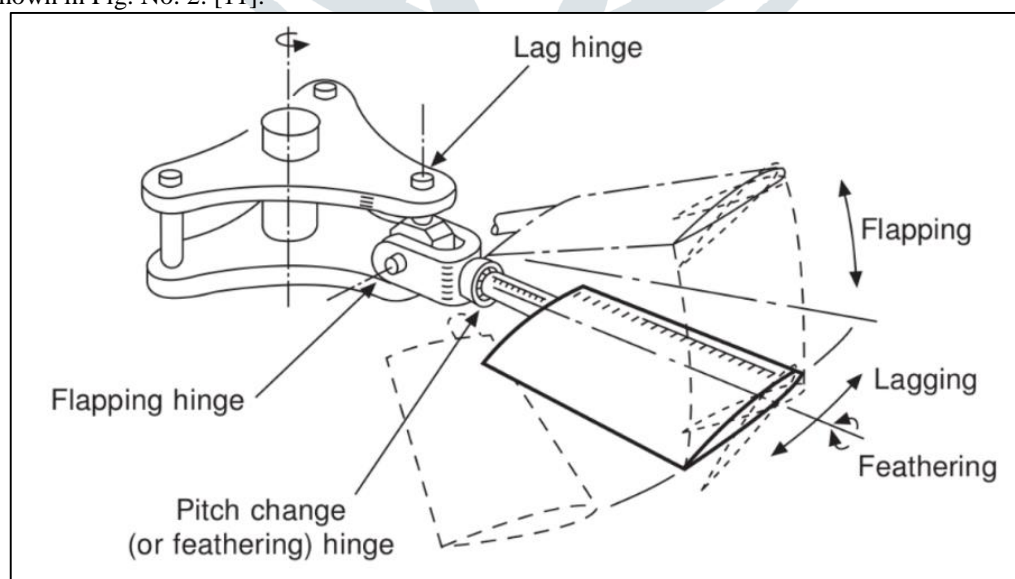

Figure 2. Rotor Blade Movements (Flapping, Feathering, and Lagging) [11]

M. S. Gupta et al. have selected and carried out a literature survey on the Black Hawk UH-60 helicopter main rotor blade. The material applied in the analysis is carbon fiber reinforced plastic (CFRP) with different stacking sequences. Specifications and performance characteristics of the Black Hawk UH-60 helicopter are presented in the paper. The material for the blade is T700S 12K/3900-2, with 700000 psi, which was incurred from the general supplier. The blade dimensional and configurational data were collected, and the blade was modeled in AutoCAD. The SC-1094R8 and SC-1095 airfoil at the tip was applied in the modeling along with required cord length and thickness. Three types of symmetrical stacking sequences were considered as the cases for

modal analysis, which was carried out in ANSYS. After comparing the displacement and maximum stress values for the cases, it is concluded that the quasi-isotropic stacking sequence is good for manufacturing the blade [16]. R. S. Reddy et al. have mainly concentrated on the local operating conditions, fuel efficiency, noise, and vibration reduction of the helicopter, which are also the benefits expected from the active blade concepts for the rotor blade. In this paper, the active twist rotor (A.T.R.) is applied instead of the conventional pitch control, which is actuated by swashplate (a component of a rotor control system). The materials considered are the steel and aluminum alloy with solid and shell elements. The modeling is carried out in CATIA and analysis in ANSYS. Active twist rotor (A.T.R.) blade comprises the twisting application through direct strain actuation with active fiber composites (A.F.C.). Materials applied in the modal analysis are steel, aluminum 7475, glass fiber, and carbon fiber. The stress-strain results are compared, and static computational fluid dynamic (C.F.D.) analysis is also carried out for accounting the lift and drag forces [17]. Jyothi et al. have performed dynamic analysis for evaluating vibration in a helicopter rotor blade with considering the aerodynamic and centrifugal forces. This study focuses on performing modal analysis for evaluating the modal frequencies and mode shapes of the rotor blade while applying aluminum and composite materials. The materials applied in the analysis are aluminum, H.M. carbon/epoxy, and E-glass/epoxy. After performing a modal analysis, the harmonic analysis is performed on the rotor blade. The modeling of the blade is carried out in NX-CAD and the analysis in ANSYS. Further, the results are obtained and documented with respect to materials. It was concluded that the H.M. carbon/epoxy is the best alternative among the other. The potential material, among others, was selected on the basis of weight, strength, and vibration values obtained from results [18]. M. M. Krishna et al. have carried out a static and dynamic analysis on the turbine comprising pre twist and composite material. The composite materials are applied for achieving their advantages such as low weight and high strength. In this paper, the variable parameters for the blade are the twist angle, thickness, and the number of layers, while the constant parameter is the material. The design parameters (i.e., width, length, and thickness) for modeling blade are adopted from "NASA Technical Paper 3641". The loading conditions are adopted from "Code Book 875-3". The material applied for the blade is Carbon Fiber Epoxy Resin Matrix with a shell model. The twist angles considered are 0° , 15° , and 45° , whereas the number of layers is considered as 1, 3, and 5. The modeling is done in Pro-E and the analysis in ANSYS with coarse meshing. Further static analysis is carried out for evaluating deformation and Vonmises stress values for different combinations of twist angles and the number of layers. Further same values are evaluated for the non-composite material blade. Further modal analysis is carried out for evaluating modal frequencies and mode shapes. Lastly, going through the obtained results, some conclusions were concluded. In static analysis, it was concluded that the maximum safe stress was obtained for 5mm thickness and 45° twist angle blade. It is also concluded that the composite blade poses better properties than non-composite. It was also concluded that the natural frequency increase with an increase in twist angle of the blade [19]. Andrzej Teter et al. have performed the modal analysis with different methods on the rotor consisting of three active composite blades. The rotor blades are applied with glass-epoxy unidirectional laminate material along with the Active Macro Fiber Composite (M.F.C.) adhered elements. On the basis of the accuracy of the results, three different methods are applied in this paper for evaluating the natural frequencies of the real structure. The active blades were designed and produced by the Lubin University of Technology. The experimental modal analysis is carried out by two dissimilar methods. The first method is carried out through utilizing a non-contact laser vibrometer (by Polytec), shown in Fig. No. 6, while second through L.M.S. analyzer (SC305) with a modal hammer (P.C.B. 086D80), is shown in Fig. No. 5. And both methods were applied for a single active blade and for three active blades, respectively. Their results were processed through P.S.V. Software. The one composite blade model was produced through numerical simulation and validated through a literature survey [21-24]. The validated model was further converted into a numerical modal and analyzed with one and three blades rotor. The finite element analysis based on the numerical model is performed in ABAQUS Software. After comparing the results of the different methods, good agreement of experimental with numerical was discovered. And also, the numerical analysis was based on the Lanczos method. It was concluded that the numerical results were differed by 8% by experimental results [20].

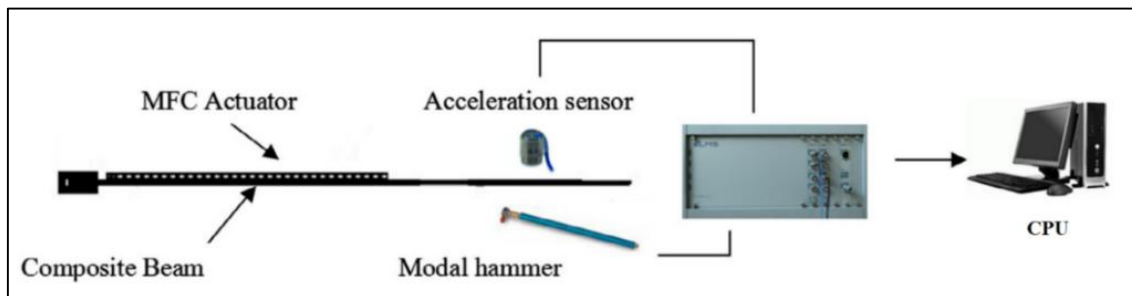

Figure 5. A measuring system utilizing L.M.S. Analyzer with Modal Hammer [20]

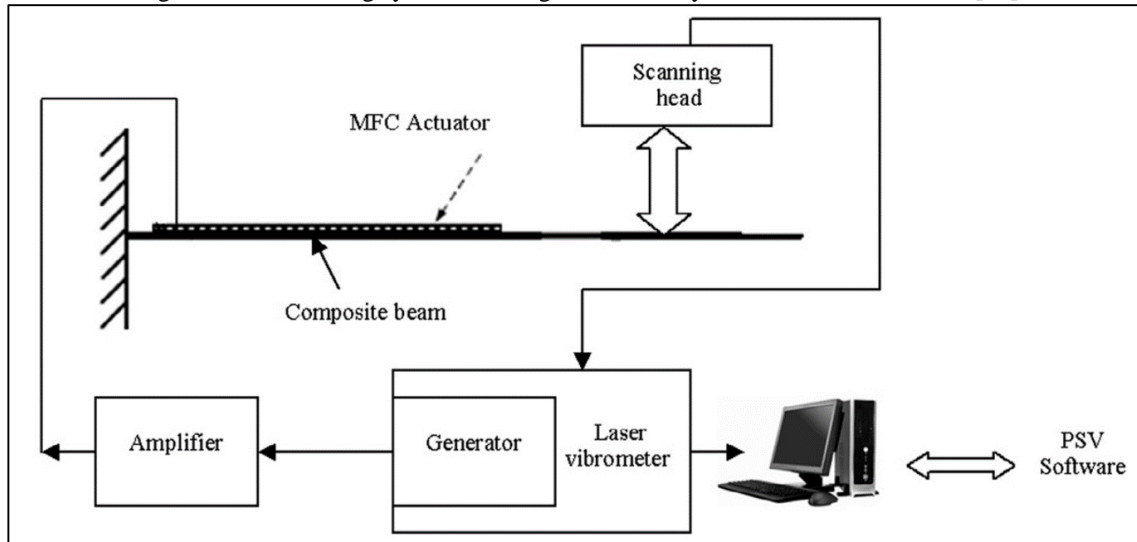

Figure 6. A measuring system utilizing Non-Contact Laser Vibrometer [20]

S. Selva Jeba Darling et al. have performed modal analysis and static linear analysis with an objective of noise reduction in helicopter rotor blades. In this paper, the sources of noise presented, which are thickness noise, loading noise, blade vortex interaction (B.V.I.) noise, broadband noise, high-speed impulsive (H.S.I.) noise and tail rotor noise. It is also discovered 65% of the noise is generated from the main rotor blade. This noise causes community annoyance and adversely affects stealth performance. Materials applied for the rotor blade in this paper are the carbon fiber epoxy, glass fiber epoxy, and titanium alloy. The NACA 230011 series airfoil is utilized for blade modeling. Modeling is carried out in CATIA and the analysis in ANSYS. First, theoretically, the natural frequency and drag force are calculated. Further, the modal analysis and the static linear analysis with drag force and boundary conditions are performed. The results obtained were documented, and it was concluded that a carbon fiber epoxy is a potential option, among other materials [25]. B. Peeters et al. have performed two types of vibration-based damage detection on helicopter real composite main rotor blade. The damages comprising potential occurrence are the impact damage, matrix cracks, delamination, and blade unbalance. The monitoring and damage detection methods are dependent on the modal properties, whereas here, the coordinate modal assurance criterion (COMAC) and modal strain energy method are utilized. These techniques are dependent on the law, which consists of the changes in the local system that affect the modal properties at the global level. These techniques consider the modal properties as baseline and detect or compare the failures in the system. The main rotor blade utilized in this paper is adopted from PZL SW-3 Sokoi Helicopter [27]. This rotor blade structure consists of roving glass fiber, D-spar, Nomex honeycomb core, and glass fiber reinforced plastic (GFRP) skin. Experimental modal analysis was carried out on a non-rotating suspended rotor blade for evaluating modal properties. The components utilized in the experimental modal analysis are LMS SCADAS III, P.C. with the L.M.S. Test. Lab 11A software, 55 P.C.B. 333B30 accelerometers, P.C.B. 086C03 impact hammer, P.C.B. 208C03 impedance head and electrodynamic shaker with stinger and amplifier. After experimental modal analysis, the two model-based monitoring methods were applied, and an unbalance mass was attached to stimulate the damage. Finally, it was concluded that the COMAC technique was less sensitive and wasn't able to detect the location of the added mass. The strain energy method uses several approximations for evaluating damage index but consists of good detection possibilities and sensitivity [26]. P. D. Haridas et al. have performed experimental analysis on a thin-walled composite rotor blade through structural health monitoring (S.H.M.). A composite rotor blade undergoes various damages, such as delamination, vibrating load impact, low-velocity impact, matrix cracking, etc. The S.H.M. provides focused prediction over the damages. In this paper, the material utilized for the thin-walled rotor blade is unidirectional carbon fiber. In detail, the Carbon Fiber Unidirectional Fabric-6 K.U.D. Fabric-360 GSM material is utilized. It also consists of 0° and 90° plies with eight layers of geometry. The tip deflection experiment with various loads for the four composite rotor blades is carried out. The natural frequency is evaluated at its undamaged condition. It was concluded that the deflection increases with an increase in load in the case of a static tip deflection experiment. The strain values induced in dynamic experimentation in X, Y and Z direction for damage and undamaged rotor blade are increased with the increase in rpm of rotor blade [28]. Pratik Sarker et al. have performed coupled free and force bending-torsion vibration analysis on a helicopter composite rotor blade at hovering condition. The helicopter rotor blade undergoes continuous bending and twisting, which causes a higher vibration level leading to failure. The blade utilized in this paper is adopted from Messerschmitt Bolkow Blohm Bo 105 helicopter [30]. The cross-sectional properties and material properties are adopted from the literature [31-33]. The material utilized for the blade consists of outer orthotropic fiberglass-epoxy outer skin, inner honeycomb structure, and Polymethacrylimide (PMI) inner core [31-33]. The mathematical model is solved by a governing equation consist of cross-sectional parameters. Initially, for the rotating and non-rotating cases, the natural frequencies and mode shapes are evaluated. Validation of an analytical solution is achieved by comparing it with the finite element model. The modeling and analysis are performed in ABAQUS Software. It was concluded that the frequencies in the non-rotating case are lower than that in the rotating case due to centrifugal force stiffness in

the rotating case. Due to the closeness of the mass center and shear center, it was also discovered that the effect of coupling on bending and torsion is less. It was also discovered the time-varying harmonic, and torsional deflection frequency is higher than bending deflection [29]. Daiju Uehara et al. have performed optical deformation measurement and operational modal analysis (O.M.A.) on a flexible rotor blade, a hovering condition. Operational modal analysis (O.M.A.) is a technique that is utilized for extracting modal properties of a structure in working condition. O.M.A. only requires measurement of response under operation or ambient conditions, whereas the classical modal analysis requires the measurement of input force and output response. This makes O.M.A. well suited for measuring dynamic parameters of rotating rotor blades, especially in case of aerodynamic excitation forces measurement. In O.M.A., there is a need for on-blade sensors, which are connected to the power supply through electrical slip rings. This raises the blade sensor integration problems. The optical techniques utilized for deformation measurement are divided into laser-based and image-based techniques. Some of the examples of laser-based optical deformation measurement techniques are holographic interferometry, projection Moiré interferometry, and electronic speckle pattern interferometry [35-38]. These techniques utilize the laser, specialized optical setups, and procedure in order to measure full-field deformations. The image-based optical technique utilizes the images of the structure captured through the camera. The photogrammetry is a common example of an image-based optical technique and is applied widely due to its robustness and ability to capture full-field deformation. The examples of image-based optical techniques are Stereo Pattern Recognition (S.P.R.), Multi-Camera Stereo Photogrammetry, and Three-Dimensional Point tracking (3DPT). A novel technique that falls under the photogrammetric measurement technique is Digital Image Correlation (D.I.C.). The Digital Image Correlation (D.I.C.) components setup is shown in Fig. No. 7. This paper focuses on a combined DIC-OMA approach for measuring the time-dependent continuous deformation of an extremely flexible two-bladed helicopter rotor blade at hovering condition. The rotor blade is produced through a thin carbon fiber ribbon with negligible stiffness, and this makes the D.I.C. potential option for measuring its deformation. In this paper, the two O.M.A. algorithms utilized are the Natural Excitation Technique (NExT)-Eigensystem Realization Algorithm (E.R.A.) and Complexity Pursuit (C.P.). The NExT-ERA and C.P. algorithm flow diagram is shown in Fig. No. 8. For capturing blur-free images, the rotor blades were painted with fluorescent paint, and a laser strobe was utilized. It was concluded the D.I.C. technique was very beneficial in measuring full field deformation. Further, these deformations were inputs to O.M.A. algorithms in order to evaluate the modal frequencies, mode shapes, and damping ratio of the rotating frame. It was discovered that the modal frequencies found through C.P. were well agreed with numerical predictions, but the NExT-ERA raised some discrepancies. It was also concluded that the damping part remains to be most difficult in the modal analysis. Finally, it was concluded that the D.I.C. deformation measurement with C.P. modal identification is very versatile [34].

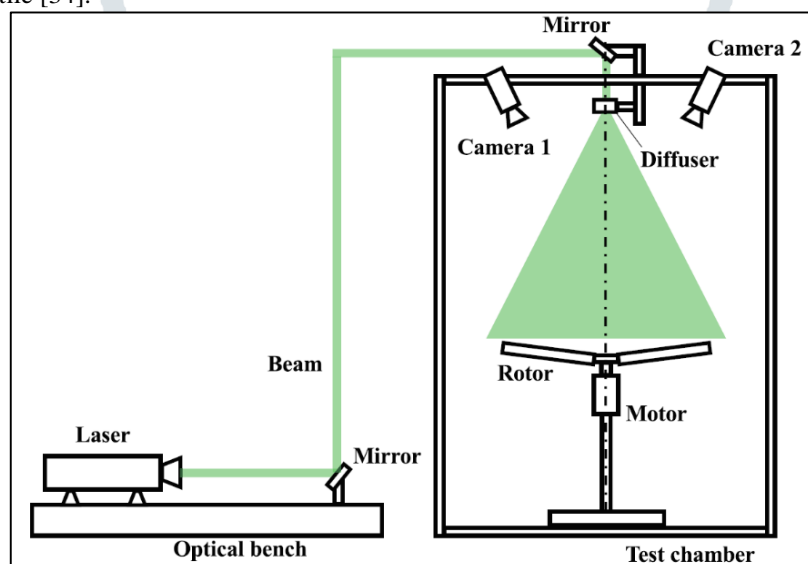

Figure 7. Schematic representation of Digital Image Correlation (D.I.C.) Components Setup [34]

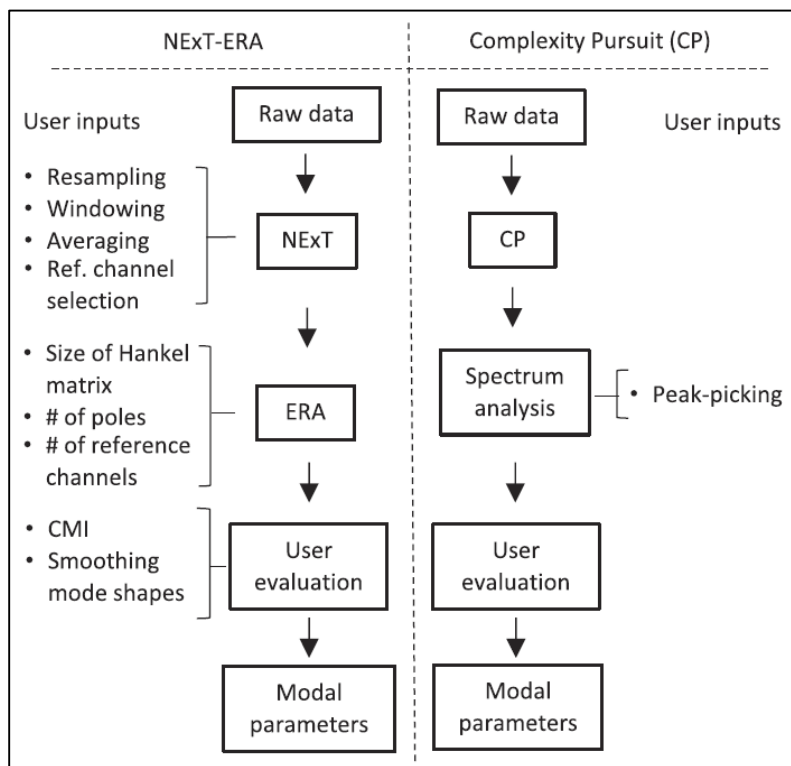

Figure 8. Block Diagram of NExT-ERA and C.P. Algorithms [34]

S. Rizo Patron et al. has performed the operational modal analysis with Digital Image Correlation (D.I.C.) on a 2m diameter helicopter rotor (reduced scale) blade. The rotor blade utilized in this paper consists of a composite rotor blade with a foam core wrapped in carbon fiber layers along with a carbon fiber stiffening cuff at the root. A pattern of black speckles on the matte white background of the rotor blade is painted for D.I.C. measurements. The evaluation of modal properties experimentally comprises providing a known excitation, then measuring the resulting response, and finally extracting of modal properties. The blade is rotating at 900 rpm, and the images are captured at 1000 fps (frames per second) with pair of high-speed digital cameras. Bending deformation is measured by D.I.C. with these captured images with a spatial resolution of 7.2 mm and an accuracy of 60 microns. The modal parameters are evaluated by applying the Ibrahim Time Domain (I.T.D.) method. The model parameters comprise natural frequencies and mode shapes evaluated from bending deformation. The initial three bending modes are evaluated for each rotation speed and further compared with the analytical finite element model. It was discovered that the mode shapes evaluated through an experimental analysis were in a close match with analytical predictions. Increasing the image capturing is affecting the decrease in sampling rate. It is also discovered that this may increase accuracy and spatial resolution. The experimental and analytical results agreed to within 0.2% in the best case, and 10% in the worst-case [39]. A.D. Gardner et al. have carried out a review on measurement techniques for unsteady helicopter rotor flows. This paper summarized the work of helicopter aerodynamics group in Gottingen on measurement techniques for unsteady flow on the helicopter rotor blade. The helicopter rotor blade undergoes unsteady flow during the forward flight in order of 1 to 10 Hz. The pulse phenomena comprising the Blade-Vortex interaction (B.V.I.), Dynamic Stall (D.S.), or Shock-Buffer needs frequencies acquisition in the range of 500 Hz to 10 kHz. The techniques for the data gathering during unsteady aerodynamic conditions are Particle Image Velocimetry (PIV), Background Oriented Schlieren (B.O.S.), Infrared Thermography (I.R.T.) are utilized. These techniques are compared with each other in this paper. It is concluded that all the methods provide a better understanding of unsteady flow over the helicopter rotor blade [40].

Material properties of the rotor blade play a very critical role in its performance under vibrations. The natural frequency of material depends on the mass and stiffness of the components. For improving the natural frequency, the material stiffness must be high, and mass must be low. These properties are discovered in the composite materials, but for there application in replacement of metals must be firmly proven. In this paper, the composite materials deployed for the rotor blade for improving its vibration characteristics are reviewed. The materials applied for the helicopter rotor blade with respect to the literature are presented in Table No.1 [1,11,16-20,25-29,34,39].

Materials	Analyses Utilized	References
Nomex Honeycomb Structure Core, Carbon Fiber Crossply Wrap, Stainless Steel Tube, Carbon Fiber Inner Wrap, Glass Fiber Spar and Carbon Fiber Crossply Skin.	Eigen Value Extraction through Lanzos Method and the Modal Analysis	[1]
Carbon Fiber	Modal Analysis	[11]
Carbon Fiber Reinforced Plastic (CFRP)	Modal Analysis	[16]
Steel and Aluminum Alloy	Modal Analysis	[17]
Aluminium, HM Carbon/Epoxy And E-Glass/Epoxy	Static Analysis, Modal Analysis and Harmonic Analysis	[18]
Carbon Fiber Epoxy Resin Matrix	Static Analysis and Modal Analysis	[19]
Glass-Epoxy Unidirectional Laminate	Experimental Modal Analysis	[20]
Carbon Fiber Epoxy, Glass Fiber Epoxy and Titanium Alloy	Linear Static Structural Analysis and Modal Analysis	[25]
Roving Glass Fiber, D-Spar, Nomex Honeycomb Core and Glass Fiber Reinforced Plastic (GFRP) Skin	Experimental Modal Analysis	[26]

Carbon Fiber Unidirectional Fabric-6 KUD Fabric-360 GSM	Experimental Analysis (Fast Fourier Transform (FFT) Analysis)	[28]
Outer Orthotropic Fiberglass-Epoxy Outer Skin, Inner Honeycomb Structure and Polymethacrylimide (PMI) Inner Core	Numerical Analysis and Modal Analysis	[29]
±45 AS4/3501-6 Prepreg with Tungsten Rod	Operational Modal Analysis (OMA) with Digital Image Correlation (DIC)	[34]
Foam Core wrapped in Carbon Fiber Layers	Operational Modal Analysis (OMA) with Digital Image Correlation (DIC)	[39]

Table 1. Materials and analyses deployed for helicopter rotor blade

Modal Analysis:

In the last three decades, the modal analysis has achieved enormous interest among the scientists, when it comes to determining, optimizing, and improving the dynamic properties of any structure. It has become a very efficient and potential tool for studying the dynamic properties of any structure. Modal analysis has discovered its applications not only in mechanical and aeronautic engineering but also in several engineering regions as civil engineering, biomechanical engineering, space research, acoustical engineering, transportation, and nuclear engineering. Modern technology demands for lighter, flexible, and strong components in dynamic conditions, which necessitates the study of their dynamic characteristic responses. The space operations and the modern super vehicles require the highest strength to weight ratios for achieving specific performance under extreme conditions, which also raises a requirement of evaluating and analyzing their dynamic properties [41].

Modal analysis can be defined as the process carried out for determining the dynamic properties (i.e., modal parameters) of any structure, which are modal frequencies (natural frequencies) and mode shapes. The resonance is nothing but a destructive phenomenon that occurred due to the equating of forced and natural frequency of any structure in its operation. Modal analysis is the most utilized tool when it comes to determining the natural frequencies of any component, which is also found in the literature [1,11,16-20,25,26]. The alone modeling of the component cannot evaluate the dynamic characteristics; the modal analysis is required in addition. The terms in a modal analysis like a modal model and modal data represent the mathematical formulation and the information of characteristics, respectively. The modal analysis also provides the basic input parameters for the spectrum analysis and harmonic or transient analysis. Modal analysis in ANSYS software is referred to as linear analysis, as it ignores the non-linearities such as plasticity and the gap between the elements. The modal analysis also provides validation or comparison results data for the different experimental analysis [1,11,20,26]. The structure in modal analysis with no loading condition is possible to analyze because it only requires the materials properties, geometry model, and boundary conditions as input parameters. The steps performed during any general modal analysis in ANSYS are as follows [41]:

1. Initially, specify the material properties.
2. Define the 2D or 3D model geometry of the component.
3. Specify the boundary conditions and meshing parameters.
4. Determine the modal frequencies and mode shapes through the solution.
5. Lastly, observe and review the obtained results.

Operational Modal Analysis (O.M.A.):

Operational modal analysis (O.M.A.) is also known as the ambient modal identification method. O.M.A. comprises the detection of the modal properties of any structure under its ideal operating condition. Simply it is defined as the method utilized for accounting the modal properties of any structure, which consists of natural frequencies, damping ratios, and mode shapes. O.M.A. was initially utilized in civil engineering for structures like buildings and bridges, whose free vibration or forced vibration tests with known inputs are very expensive and difficult to evaluate. The ability to identify and to measure the output vibration characteristics without applying or need of any inputs makes it a potential option for vibration analysis applications. The O.M.A. also comprises some drawbacks, such as it requires proper data of loading conditions, and the modal properties obtained are at ambient vibration level (which are lower than actual service vibration level). The O.M.A. methods are classified in several domains, which are represented in Fig. No. 9 [42-46]. In the literature, it is discovered that the O.M.A. is possible to apply in combination with full-field optical deformation measurement and digital image correlation (D.I.C.) [34, 39].

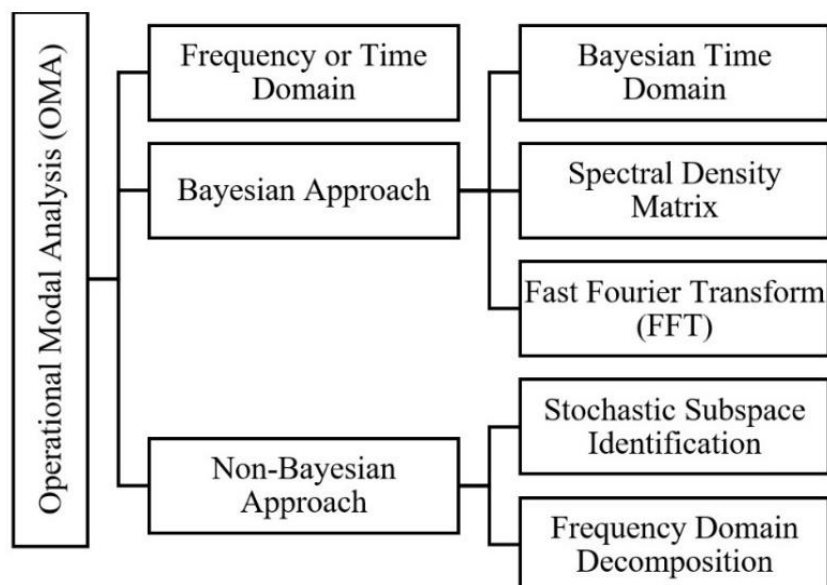

Figure 9. Types of Operational Modal Analysis (O.M.A.) [42,46]

Fast Fourier Transform (FFT) Analysis:

The combination of a series of simple sinusoids with dissimilar frequencies, amplitudes, and phases is known as a waveform. The series of such sine waves is the Fourier series, in which the Fourier or spectrum analysis is utilized for separating the signal into sine wave components. The vibration is nothing but displacements with certain frequencies, which make its analysis fall under frequency domain analysis. Fast Fourier Transform (FFT) is the analysis which utilizes separate Fourier transform waves in an efficient algorithm. Separate Fourier transform is also known as the discrete Fourier transform (DFT), which comprises the same principle of sine waves with discrete frequencies. DFT is the power of two of the signal lengths, which increases the processing speed. Explaining through an example, if N is signal length, then DFT needs N^2 and FFT needs $N \log_2(N)$ operations. Similarly, the number of frequency lines will be $N/2$ [47]. In the literature, for clear understanding, the simple time-domain waveform is compared with its FFT waveform. This simple wave consists of frequencies as 22, 60, and 100 Hz, with amplitude 1, 2, and 1.5g; and with some added noise. The comparison is represented in Fig. No. 10 [47].

Giovanni Betta et al. have proposed a digital signal processing (D.S.P.) based FFT-analyzer for fault diagnosis based on vibration analysis. A small-size three-phase asynchronous motor was utilized for testing and excellent detection, low false alarm rate with good diagnostic performance was discovered [48]. Yukun Liu et al. performed an amplitude recovery method (A.R.M.) with FFT as a signal pre-processing for induction motor fault diagnosis [49]. S. S. Patil et al. have performed vibration analysis on electrical rotating machines through utilizing FFT. The electrical rotating machine utilized for the experiment is a permanent magnet DC-motor with 0.25 HP, 3000 rpm, and with variable speed. The obtained frequencies were compared with ISO and German V.D.I. Standards, and on the basis of the frequency range, the faults were identified [50].

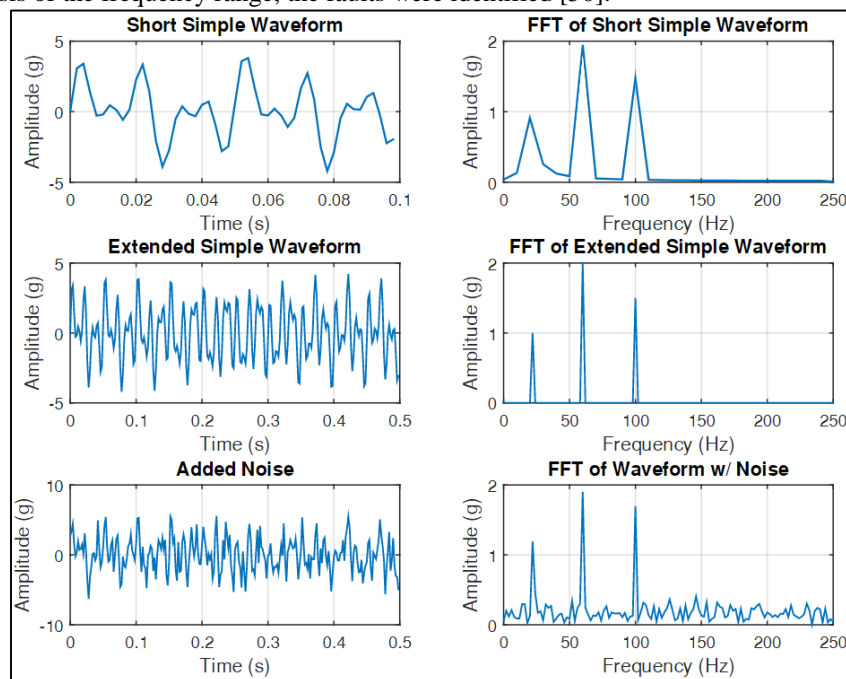

Figure 10. Comparison of Simple Waveform with FFT Waveform [47]

Power Spectral Density (PSD):

The vibrations that occurred in the actual operation mostly consist of random vibration caused due to random events. The random frequency comprises infinite and unpredictable frequency components. The FFT analysis deals with finite frequency components, but in the case of random vibration, power, spectral densities are utilized. Power spectral densities (S.P.D.) is also known as spectral acceleration densities (A.S.D.). PSD comprises the multiplication of frequency signals from FFT by its complex conjugate and the amplitude than becomes g^2 . Further, the amplitude values are normalized (with the unit as g^2/Hz) to a frequency bin width, which sum-up the advantage of bin width independency. It results in its comparative nature with vibration environments like MIL-STD-810G. For better understanding, the jet aircraft cargo exposed to some acceleration levels (which are needed to be provided to the government for any cargo) is represented in Fig. No. 11 [47, 51].

S. Lieratore, et al. have performed a power spectral density (S.P.D.) analysis on a simply supported aluminum beam. The analytical analysis was performed before S.P.D., as it is preferred as experimental analysis. The experimental setup consists of an aluminum beam with a piezoelectric actuator and sensor for estimating resonance frequencies; small mass and cuts were utilized to simulate the damages. Finally, good agreement between analytical and experimental was discovered [52]. Stephen Corda et al. have performed a vibration analysis on NASA F-15B/Flight Test Fixture 2 testbed. The vibration analysis is carried out for evaluating the in-flight vibration environment advantages on its design and integration basis. Power spectral density is utilized for accelerometer in-flight data, which consists of frequency ranging from 15 to 1325 Hz. Further, the results are compared with flight-qualification random vibration test standards. It was discovered that the in-flight vibrations were lower than the random vibrations obtained. Yinlong Rong et al. has performed acoustic fatigue analysis on a thin-walled shell structure by utilizing the power spectral density method. The structure utilized for testing is the thin-walled shell structure of the aluminum alloy. The S.P.D. was performed with a noise of 145, 148, and 151 dB, and the linear length of material 7075 aluminum is 300 mm with 1.5 mm thickness. The PSD was utilized in combination with fatigue damage theory. It was discovered that the position of the damage was located at their constraint location, where the random vibration effect was critical [54].

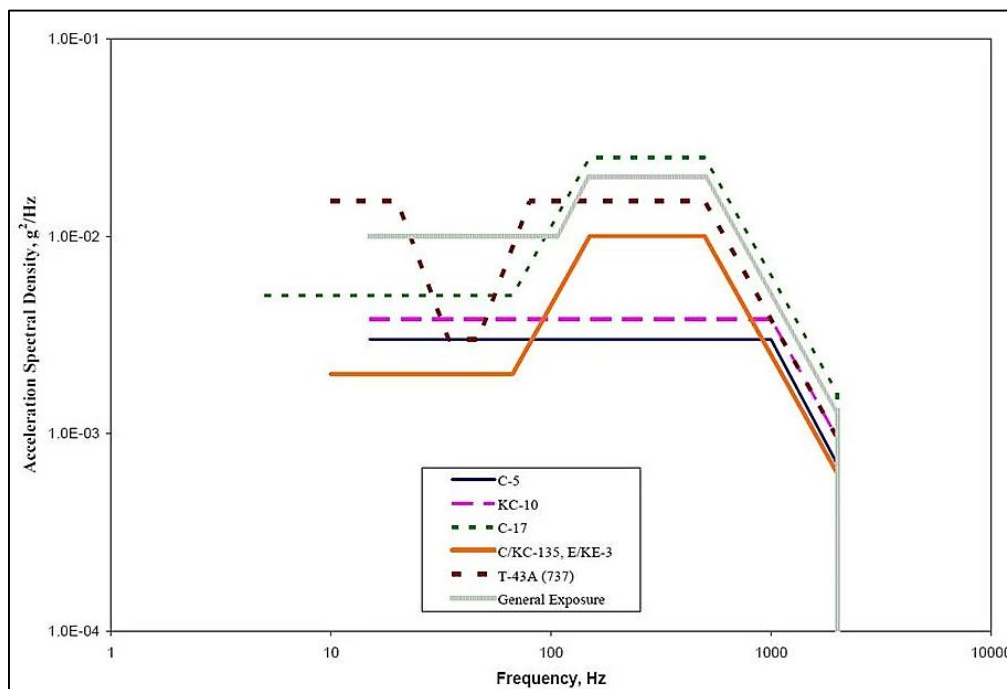

Figure 11. Jet Aircraft Cargo Exposed to some Acceleration Levels (S.P.D.) [47,51]

Spectrogram:

A spectrogram is a tool utilized for representing the frequency and amplitude data with respect to time. It divides the time domain data into parts, and the FFT of these parts is combined in one another for the purpose of visualization. It consists of combining the frequency, amplitude, and time data into a 3D plot, further turning this plot in a logarithmic scale and also consist of the addition of colors for better visualization. It can be better understood through an example in which a vibration data of car engine revving is represented through a spectrogram, as shown in Fig. No. 12 [47].

Arun P. et al. have extracted the normal vibration data of bearing operation, further spectrogram images and their Peak-Signal-To-Noise ratio (PSNR) are generated and evaluated respectively. It was discovered that the results from the Spectrogram were differing from baseline vibration data when it comes to Inner Race Failure (I.R.F.), Roller Element Defect (R.E.D.), and Outer Race Failure (ORF). It was also concluded that the method comprises 96.77% sensitivity and 100% specificity when it comes to discrimination of faulty bearings [55].

Conclusion:

Extensive research has been carried out on the materials and analyses deployment in the helicopter rotor blade, which is being reviewed in this paper. In vibration analysis, the measurement and evaluation of modal frequencies (i.e., natural frequencies) and mode shapes play an important role. After observing the literature, it is concluded that the modal analysis in Finite Element Analysis (F.E.A.) software (such as ANSYS, ABAQUS, etc.) is mostly utilized for vibration analysis of a helicopter blade. The modal analysis is the most estimable F.E.A. tool for evaluating the modal frequencies and mode shapes of the helicopter rotor blade. Further, in the experimental vibration analysis methods, the operational modal analysis (O.M.A.) with Digital Image Correlation (D.I.C.), the FFT analysis, the Spectrogram, and PSD analysis is a most beneficial tool in vibration analysis of the rotor blade. In material deployment, it is discovered that the composite materials are potential alternatives for the metal alloys (which are still utilized). The honeycomb structure and metal-based or polymer-based foams are utilized for filling the inner core of the blades, which provides better weight reduction and stiffness to the structure. For the strengthening and structural integrity purpose, a metal spar with high stiffness is deployed. The performance and durability under harsh vibrations are found to greater in the composite blade than the metal or alloys one. The initial modal frequencies obtained for the composite blade are higher than the metal ones. It is also discovered that the modal deformations for respective frequencies are lower in composite material blades. These beneficial characteristics of composite material in the helicopter blade depends on their unidirectional properties. The material having higher modal frequencies and lower deformations is the carbon fiber composite material.

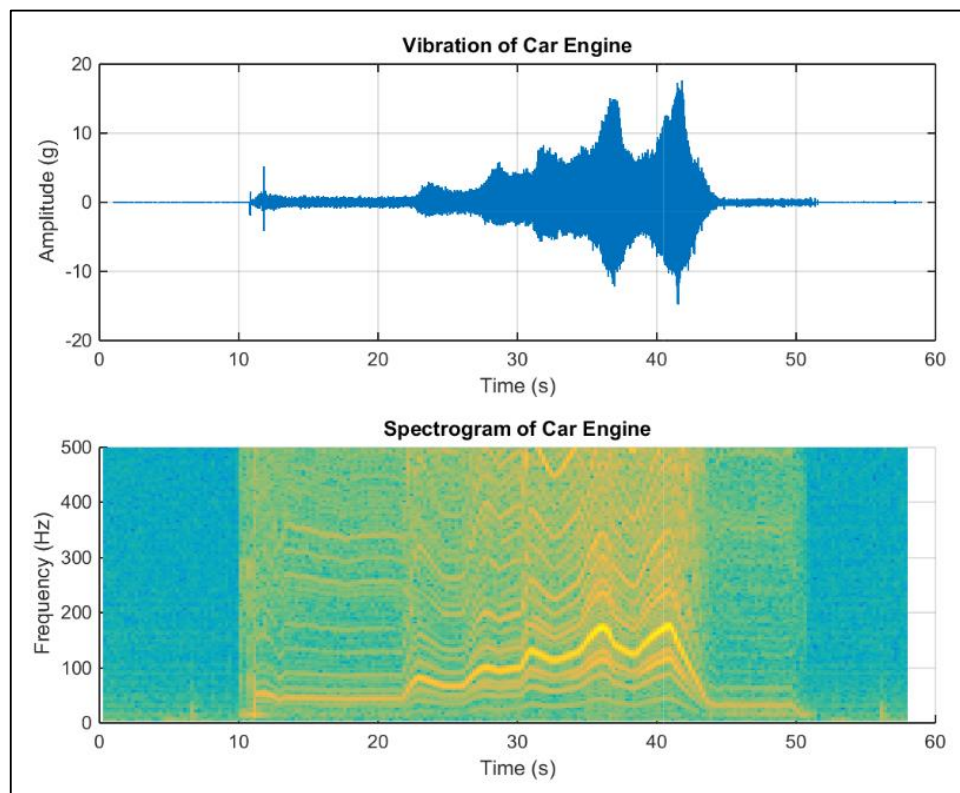

Figure 12. Vibration data and Spectrogram of Car Engine Revving [47]

REFERENCES

- [1] Dimitrios Garinis, Mirko Dinulovic, and Bosko Rasuo, "Dynamic analysis of modified composite helicopter blade," *F.M.E. Transactions*, VOL 40, P.P. 63-68, 2012.
- [2] W.T. Thomson and M.D. Dahleh, "Theory of vibration," Prentice-Hall, New Jersey, 1998.
- [3] C. F. Beards, "Structural vibration analysis and damping," Butterworth Heinemann, Oxford, 1996.
- [4] Hyeonsoo Yeo and Wayne Johnson, "Assessment of comprehensive analysis calculation of air loads on helicopter rotors," *Journal of Aircraft*, Vol. 42, 2005.
- [5] Ding-he Li, Jian-Xin Xu, and Guang-hui Qing, "Free vibration analysis and eigenvalues sensitivity analysis for the composite laminates with interfacial imperfection," *Composites Part B: Engineering*, Vol. 42, No 6, P.P. 1588-1595, 2011.
- [6] Mitsuhiro Kashiwagi, "A numerical method for Eigen solution of locally modified systems based on the inverse power method, *Finite Elements in Analysis and Design*," Vol. 45, P.P. 113-120, 2009.
- [7] Barbara M. Johnston and Peter R. Johnston, "A modified nonlinear transformation method for evaluating weakly singular boundary integrals," *Applied Mathematics and Computation*, Vol. 148, P.P. 519-535, 2004.
- [8] T. Sadowski and J. Bec, "Effective properties for sandwich plates with aluminum foil honeycomb core and polymer foam filling Static and dynamic response," *Computational Materials Science*, Vol. 50, PP.1269-1275, 2011.
- [9] Randolph A. Odi and Clifford M. Friend, "A comparative study of finite element models for the bonded repair of composite structures," *Journal of Reinforced Plastics and Composites*, Vol. 21, P.P. 311-322, 2002.
- [10] J. A. Garcia, A. Chiminelli, B. Garcia, M. Lizaranzu, and M. A. Jimenez, "Characterization and material model definition of toughened adhesives for finite element analysis," *International Journal of Adhesion & Adhesives*, VOL. 31, P.P. 182-192, 2011.
- [11] Sebastian Marian Zaharia, "The modal analysis of a carbon fiber helicopter blade," *Journal of Industrial Design and Engineering Graphics*. VOL. 10, ISSUE. 2, 2015.
- [12] John Watkinson, "The art of the helicopter," Elsevier Butterworth-Heinemann, ISBN. 0750657154, 2004.
- [13] Abdelkader Nour, Mohamed Tahar Gherbi and Yon Chevalier, "Modes shape and harmonic analysis of different structures for helicopter blade," *30th European Conference on Acoustic Emission Testing & 7th International Conference on Acoustic Emission*, www.ndt.net/EWGAE-ICAE2012/, 2012.
- [14] A. R. S. Bramwell, George Done, and David Balmford, "Bramwell's helicopter dynamics second edition," Butterworth-Heinemann, ISBN. 0750650753, 2001.
- [15] Sebastian Marian Zaharia, Ionel Martinescu, and Cristin Olimpiu Morariu, "Lifetime prediction using accelerated test data of the specimens from mechanical element," *Eksplotacja, Niezawodnosc Maintenance and Reliability*, VOL. 14 No. 2, 2012.
- [16] M. S. Gupta and Badugu Uday Kumar, "Design and analysis of black hawk uh-60 rotor blade using composite materials", *IJMETMR (International journal and magazine of engineering, technology, management and research)*, VOL. 3, ISSUE. 9, ISSN. 23484845, 2016.
- [17] R. S. Reddy, G. Narendra Babu, and K. Bavaji, "Design and analysis of an active twist rotor blades with D-spar model using C.F.D. simulations," *International Journal of Innovative Research in Advanced Engineering (IJIRAE)*, ISSN. 23492163, ISSUE. 12, VOL. 5, 2018.
- [18] J. Padmaja K. and K. Hari Babu, "Design and structural analysis of helicopter rotor blade for different materials," *International Journal of Mechanical Engineering Research and Technology (IJMERT)*, ISSN 2454535, VOL. 2, 2015.

- [19] M. M. Krishna and G. S. Karuna, "Static and dynamic analysis of composite rotor blade," Third International Conference on Recent Innovations in Science Engineering and Management, Sri Venkateshwara College of Engineering and Technology (Andhra Pradesh), ISBN. 9788193207413, 2016.
- [20] Andrzej Teter and Jarosław Gawryluk, "Experimental modal analysis of a rotor with active composite blades," *Composite Structures*, P.P. 451-467, 2016.
- [21] Arpit Kumar and Vipin Kumar, "Numerical analysis of the crack effect on the natural frequency of cantilever composite beam," *International Journal of Engineering Research (IJOER)*, VOL. 01, ISSUE. 03, 2015.
- [22] Li Jun, Hua Hongxing, and Shen Rongying, "Dynamic finite element method for generally laminated composite beams," *International Journal of Mechanical Sciences*, VOL. 50, P.P. 466-480, 2008.
- [23] Levent Malgaca, "Integration of active vibration control methods with finite element models of smart laminated composite structures," *Composite Structures*, VOL. 92, P.P. 1651-1663, 2010.
- [24] Y. Teboub and P. Hajela, "Free vibration of generally layered composite beams using symbolic computations," *Composite Structures*, VOL. 33, P.P. 123-134, 1995.
- [25] S. Selva J. Darling, C. Sri Devi, and Janany Shri Pon, "Analysis of noise reduction in helicopter rotor blades using composite materials," *Journal of Basic and Applied Engineering Research*, ISSN. 23500077, VOL. 02, P.P. 544-549, 2015.
- [26] F.L.M. dos Santos, B. Peeters, H. Van der Auweraer, L.C.S. Goes and W. Desmet, "Vibration-based damage detection for a composite helicopter main rotor blade," *Case Studies in Mechanical Systems and Signal Processing*, 2016.
- [27] K. Z. Dragan and S. Klimaszewski, "Holistic approach for structural integrity evaluation of composite main rotor blades," 17th World Conference on Nondestructive Testing, P.P. 25-28, Shanghai, China, 2008.
- [28] P. D. Haridas and P. M. Pawar, "Experimental analysis of thin-walled composite rotor blade model from structural health monitoring aspect," *Materials Today: Proceedings* 5, P.P. 5679-5691, 2018.
- [29] P. Sarker, C. R. Theodore, and U. K. Chakravarty, "Vibration analysis of a composite helicopter rotor blade at hovering condition," *Proceedings of the ASME 2016 International Mechanical Engineering Congress and Exposition*, P.P. 11-17, Phoenix, Arizona, U.S.A., 2016.
- [30] R. L. Peterson, "Full-scale hingeless rotor performance and loads," National Aeronautics and Space Administration (NASA) Technical Memorandum 110356, 1995.
- [31] "Product Information-Rohacell RIST," Evonik Industries, Essen, Germany.
- [32] "HexWeb Honeycomb Attributes and Properties," Hexcel Corporation, Stamford, Connecticut.
- [33] H. A. Rasheed, "Strengthening design of reinforced concrete with F.R.P.," *Composite Materials: Analysis and Design*, C.R.C. Press is an imprint of the Taylor & Francis Group, 2015
- [34] D.Uehara and J. Sirohi, "Full-field optical deformation measurement and operational modal analysis of a flexible rotor blade," *Mechanical Systems and Signal Processing*, VOL. 133, 2019.
- [35] W. F. Fagan, M. A. Beeck, and H. Kreitlow, "The holographic vibration analysis of rotating objects using a reflective image derotator," *Optics and Lasers in Engineering*, VOL. 2, P.P. 21-32, 1981.
- [36] G. A. Fleming and S. A. Gorton, "Measurement of rotorcraft blade deformation using Projection Moir'e Interferometry," *Shock and Vibration*, VOL. 7, P.P. 149-165, ISSN. 10709622, 2000.
- [37] M. K. Sekula, "The development and hover test application of a projection Moiré Interferometry Blade Displacement," *American Helicopter Society 68th Annual Forum*, Fort Worth, Texas, 2012.
- [38] A. Macovski, S. D. Ramsey, and L. F. Schaefer, "Time-lapse interferometry and contouring using television systems," *Applied Optics*, VOL. 10, 1971.
- [39] S. R. Patron and J. Sirohi, "Operational modal analysis of a helicopter rotor blade using digital image correlation," *Experimental Mechanics*, VOL. 57, P.P. 367-375, 2017.
- [40] A.D. Gardner, C.C. Wolf and M. Raffel, "Review of measurement techniques for unsteady helicopter rotor flows," *Progress in Aerospace Sciences*, <https://doi.org/10.1016/j.paerosci.2019.100566>, 2019.
- [41] Jimin He and Zhi Fang Fu, "Modal Analysis", Butterworth-Heinemann, ISBN. 0750650796, 2001.
- [42] Peter Van Overschee and Bart De Moor, "Subspace identification for linear systems (theory, implementation, and applications)," Kluwer Academic Publishers, 1996.
- [43] Ka Veng Yuen and Lambros S. Katafygiotis, "Bayesian time-domain approach for modal updating using ambient data," *Probabilistic Engineering Mechanics*, Vol. 16, P.P. 219-231, 2001.
- [44] Lambros S. Katafygiotis and Ka Veng Yuen, "Bayesian spectral density approach for modal updating using ambient data," *Earthquake Engineering and Structural Dynamics*, Vol. 30, P.P. 1103-1123, 2001.
- [45] Ka Veng Yuen and Lambros S. Katafygiotis, "Bayesian Fast Fourier Transform approach for modal updating using ambient data," *Advances in Structural Engineering*, VOL. 6, 2003.
- [46] Siu-Kui Au, Feng Liang Zhang, and Yan Chun Ni, "Bayesian operational modal analysis: Theory, computation, practice," *Computers and Structures*, VOL. 126, P.P. 3-14, 2013.
- [47] Steve Hanly, "Vibration analysis: FFT, PSD and Spectrogram Basics," ENDAQ. Com Blog, <https://blog.endaq.com/vibration-analysis-fft-psd-and-spectrogram#fft>, 2016.
- [48] Giovanni Betta, Consolatina Liguori, Alfredo Paolillo, and Antonio Pietrosanto, "A DSP-based FFT-analyzer for the fault diagnosis of rotating machine based on vibration analysis," *IEEE Transactions on Instrumentation and Measurement*, VOL. 51, 2002.
- [49] Yukun Liu, Liwei Guo, Qixiang Wang, Guoqing An, Ming Guo, and Hao Lian, "Application to induction motor faults diagnosis of the amplitude recovery method combined with FFT," *Mechanical Systems and Signal Processing*, VOL. 24, P.P. 2961-2971, 2010.
- [50] S. S. Patil and J. A. Gaikwad, "Vibration analysis of electrical rotating machines using FFT," *IEEE-31661*, 2013.
- [51] Steve Hanly, "Why the Power Spectral Density (PSD) Is the Gold Standard of Vibration Analysis," ENDAQ. Com Blog, <https://blog.endaq.com/why-the-power-spectral-density-psd-is-the-gold-standard-of-vibration-analysis>, 2017.
- [52] S. Liberatore and G.P. Carman, "Power spectral density analysis for damage identification and location," *Journal of Sound and Vibration*, VOL. 274, P.P. 761-776, 2004.

- [53] Stephen Corda, Russell J. Franz, James N. Blanton, M. Jake Vachon, and James B. DeBoer, "In-Flight Vibration Environment of the NASA F-15B Flight Test Fixture", NASA/TM-2002-210719, 2002.
- [54] Yinlong Rong and Shiji Li, "Acoustic fatigue life prediction of structure based on power spectral density method," ICAACE, I.O.P. Conf. Series: Journal of Physics: Conf. Series 1213, 2019.
- [55] Arun P., Madhukumar S., and Careena P., "A method for the investigation of bearing vibration based on spectrogram image comparison," RAEREST, I.O.P. Conf. Series: Materials Science and Engineering, VOL. 396, 2018.

