

# Design and Development of Automatic Operated Multi-Task Machine

<sup>1\*</sup> Mihiretu Gezahagn, <sup>2</sup>Mulugeta Tadesse, <sup>3</sup>Chernet Merkneh

<sup>1</sup>Research Assistant, <sup>2</sup>Assistant professor, <sup>2</sup> Research Assistant

<sup>1</sup>Mechanical and Industrial Engineering, <sup>2</sup>Mechanical Engineering, Material Science and Engineering  
<sup>1,2,3</sup> Wolaita Sodo University, Wolaita Sodo, Ethiopia

**Abstract:** Now days with increasing level of furniture needs profiling, sawing, drilling, and grinding machine have a great effects or positions for making the metal and wood ready to produce desired shapes. The efforts required in achieving the desired output can be effectively and economically be decreasing by the implementation of better designs. Profiling, splitting and drilling machine are used in most applications; like wood splitting machine to make naturally circular woods to give shapes and to get easier or decreasing weight; to make flat or rectangular shape. While drilling machine make a hole as we want and to make continuously manufactured hole which is used to produce socket and making desired shape by adjusting a lever. In this project a multi task wood and metal operation machine is designed to operate simply to saw, grind, smooth and drill metal and woods in various operation to produce various products. And it is also designed to be economically accepted cheapest and very simple to use.

**IndexTerms - Productivity, Furniture, safety, Multi-task, Holder.**

## I. INTRODUCTION

### 1.1. Multi-Task Machine

Multi task metal and wood machine is best and widely using machine in metal and wood work shop for the furniture making and modification of machine component. Wood saw machine is typically with a circular thin blade and operated using a rotation from dynamo motor. It is a machine with a toothed rotating disc or moving band and it is the center piece of any work shop and is the first major purchase of wood working equipment for most wood workers. A circular saw is the best machine for cutting ferrous and non-ferrous materials. A circular saw is a tool for cutting many materials such as wood, sheet metal, masonry, plastic or sheet metals and may be hand-held or mounted to a machine. Circular saw blades are specially designed for each particular material. They are intended to cut and in cutting metal are specially for making rip-cuts, cross cuts, or combination of both. The designed machine is commonly powered by electricity, but may be powered by a gasoline engine or a hydraulic motor which allows it to be fastened to heavy equipment, eliminating the need for a separate energy source. The designed machine is to saw the wood in line with grains, to smooth work pieces with high quality, to drill through desired distance. It also efficiently operates drilling and grinding application. Whether a person interested to cut with or against the grain or at any angle it is possible by adjusting the lever on the machine body. The hole is generated by the rotating edge of a cutting tool known as the drill exert large force on the table of work clamped. Generally, sawing, grinding and drilling machine is the most essential machine in the workshop; there is no operations on metal and wood can be done without this machine.

### 1.2. Background

Before the invention of metal and wood working machines such as sawing, drilling, wood lathe machine etc. wood was shaped by using an axe and other traditional methods as shown in figure below.

These traditional methods lead to over weight on the desired objects when using an axe for shaping wood we cannot profile all dimensions accurately so they assume that increasing dimensions of overall desired object have better to strength These leads over weight on the desired objects and also the produced material have Poor surface finish due to these reason the object hasn't pleasant. by using modern finishing material like file (a tool with a roughened surface, used for smoothing or shaping a hard material) this process results wastage of products and forces:-when using axe; we consider only on getting desired object and no matter what happens to chips (a small, thin piece removed in the course of chopping, cutting or breaking a material. The process also needs more time to produce the desired shape. So the significance of this project focuses on designing of productive multipurpose machine with high productivity.



Fig-1: Traditional method of wood sawing.

### 1.3. Statement of Need

The continuous quest to have the problems of man and his growing needs has led to the establishment of factories and others industries, which necessities an intermediate technology.

The problem that initiates me to design automatic operated profiling machine is that there is no developed process to saw woods and sheet metals, to drill the hole through the desired distance and to smooth wood and metals in accurate dimension with safe operation. Due to this problem it has been identified that there is defect which affects the excellence of designing in the market which intern affects the income of one's country. However, woodworking machines that was in use before are:-

- No longer efficient for mass production;
- Dimensionally limited;
- The risk of injuries higher;
- Only have one operation;
- Have Limited power;
- Difficult to move place to place;
- Time taken.
- Poor surface finishing
- Wastage of products and forces



Fig-2: Injuries on machine operators.

Then, there comes the need for urgent attention to a better, safe, high productive and efficient wood, plastic, ceramic, metal and fiber glass machine.

### 1.4. Significance of The Project

The significant of the project are listed below;

- The design has good capacity for cutting, smoothing, shaping and grinding operation
- Easily operated
- Design with parts that are easily repair and replace

Generally, the significant of the project is to satisfy the customers in ceramics, metal and wood industries, workshops and garages to operate easily with accurate dimension.

## II. LITRUTURE REVIEW

### 2.1. One Directional Circular Saw

In America in city of Harvard, Massachusetts they believed a Shaker woman named Tabitha Babbitt appears to have also discovered a circular saw entirely of her creative idea. As legend has it, she got the point from watching two men trying to split wood. At the time, these saws have only ability to cut in single direction; making ripping logs was a horribly tedious task. She saw that the labor wastes their energy to draw back the saw blade and she designed and develop the machine as shown fig-3 below.

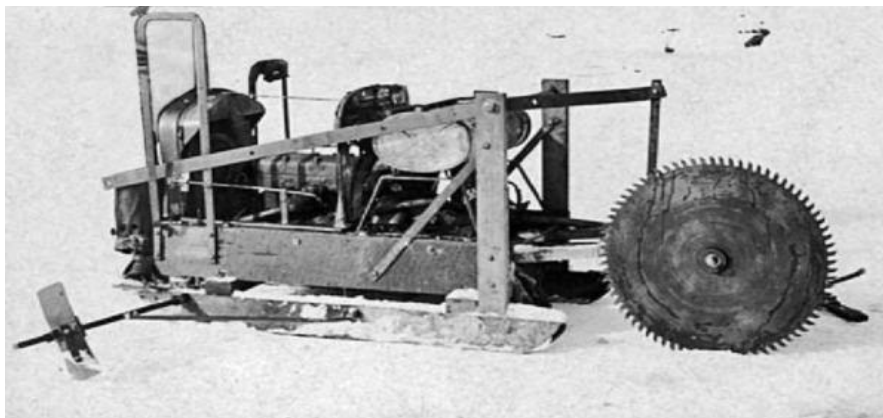

Fig-3: Wood saw machine invented by Tabitha Babbitt [3].

But Relatively the designed machine have ability to operate with both direction (forward and backward); The material with high length, width, and less thick is difficult to split by using recently invented machine but in proposed machine it is possible to do

this operation effectively in addition to this the machine can operate smoothing, drilling through distance, grinding and angle cutting machine.

## 2.2. Panel Saw

A panel saw is one of sawing machine with a sliding blade that cuts sheets into required sizes. A sliding panel saw was discovered by Wilhelm Elmendorf in 1906 in Germany. Its invention develops a new standard in woodworking, with some differences from recent machines. Up to that time, a table saw had no operation to create edge [2].

Limitation of panel saw:-Panel saw is designed mainly for cutting only woods previously it is not designed for cutting hardened materials even harden woods, Routers are not recommended for work piece that are smaller than the carriage. Do not cut pieces that are so small that the hand must behind the carriage to hold the piece in place

The designed new machine reduce the above limitation by reducing complexity of machine operation method, installing safety cover and using breaker switch to shut down automatically if any electrical accident happens, applying motor which have to operate wood, plastic and sheet metals with their blade.

## III. METHODOLOGY

### 3.1. Procedural Methodology

#### ➤ Recognition of need

A project of multi-task machine begins when a workshop or company recognizes a need, or identifies what the buyers and the company workers needs, for a product, device or process. So our need is simplified low cost multi-task metal and wood machine with safe operation principle.

#### ➤ Definition of problem:

This involves all the necessary product or process to be designed. We already described the problem why we are going to do this project

#### ➤ Data collection method

Different ways has been used while collecting, analyzing and evaluating data.

- ❖ Data collection; data recording about multi-task metal and wood machine, raw materials by referring books. All the necessary data is collected and arranged. It can be done in two data collecting methods:

Primary data about wood, metal and aluminum machine;

- Observation
- Interview with concerned body/operators

Secondary data about machines and working area

- Different books
- Literatures
- Collecting data about wood and metal machines from different sources like written books, internet websites and workshops.

- ❖ Data analysis about multi-task machine;
- ❖ Observation
- ❖ Design and sampling method of multi-task machine;

This involves the application of engineering which related to stress, torsion and deflection. Engineering area books which are dynamics, machine design and strength are used. In this stage the following tasks are performed.

Using basic design equations and based on specifications of data perform

- Engineering analysis of multi-task machine parts and systems;
- Stress and strength analysis of multi-task machine parts.

### 3.2. Organization of the project

This paper illustrates introduction of multi-task metal and wood machine, literature reviews that define the meaning and invention stage of the machine, material selection, geometrical analysis and part design calculations. It also gives result and conclusion about designed (multi-task machine).

### 3.3. Conceptual design

Before choosing the right outline for our multi-task machine, we have tried different conceptual designs. Thus, here we will see each and select the best based on the following criteria:

- Cost, Manufacturability, Maintainability and Lapping quality/efficiency

Deliverability of the project

- Depending on cost:-the machine with three main operations has less cost compared to market.
- Depending on power:- by changing the dynamo up to 4hp and 4500rpm we can use; so we can select our desired power amount;
- Depending on time:-times to get the machine from market kill more time;
- Depending on dimensional accuracy:-the accuracy of dimensions are perfect;

## IV. DESIGN OF COMPONENTS

### 4.1. Detail Design analysis

Design procedure any design procedure has to follow the essentials of the design process. The design procedure describes, in steps, the evolution of a design. The following sequence is often followed:

- Recognition, Synthesis, Analysis, Selection of material, Calculation, Revision and modification and Report.

**Material selection**

The following factors should be considered for the selection of materials for design of machine elements

1. Availability;
2. Cost;
3. Mechanical Properties;
4. Manufacturing consideration.

**4.2. Geometrical Analysis**

Geometric analysis of machine

Given parameters and assumptions:

- Length of table=1200mm
- Height of table=890mm
- Width of table=1000mm
- Overall height of machine=1100mm

Geometric analysis of material to be operate

Then these are the specifications;

- Material to be cut mild sheet metal, wood, metal and plastic
- Maximum diameter of work piece to be done= 300mm (round)
- Maximum length of work piece to be done=2000mm
- Maximum thickness of work piece to be done=100mm
- Type of saw blade=HSS(High speed steel)
- Blade diameter=250mm
- Blade bore diameter=40mm(32,40 and50mm are most common in ferrous cutting saw blades)
- Blade thickness=2.5mm
- Blade tooth style=C (Heller or Cochrane teeth) most common tooth style of blade for cutting ferrous metals.

Then taking maximum diameter, length and thickness of the work from the beneficiaries; this is due to determine power requirement. And also blade diameters are available in many dimensions.

**4.3. Detailed Design analysis of components****A. Motor**

- Motor selection consideration

The overall motor performance is related to the following parameters

- Acceleration capabilities, Breakdown torque, Efficiency, Enclosure type, Heating, Inrush current, Insulation class, Power factor, Service factor, Sound level, Speed and Start torque

A good motor specification should define performance requirement and describe the environment within which the motor operates.

Specification contents should include;

- Motor horsepower and service factors
- Temperature rise and insulation class
- Maximum starting current
- Minimum stall time
- Power factor range
- Efficiency requirement and test standard to be used
- Load inertia and expected number of starts

**Power of the motor**

To calculate the power rating of the electric motor Nm, first we calculate the cutting force (Fc) which is given by the formula:-

$$F_c = \pi D t F_s \quad (\text{For round}) \dots \dots \dots (4.1)$$

$$F_c = L t F_s \quad (\text{For others}) \dots \dots \dots (4.2)$$

Where: D=diameter of the work piece (mm)

t=thickness of the work piece (mm) =100mm from specification

F<sub>s</sub>=ultimate shear strength (N/mm<sup>2</sup>) =410Mpa (1023 plain carbon steel)

L=length of work piece (mm) =maximum up to 2000mm

But for our project the machine is cut the flat sheet metal and wood. So we have to use second equation.

$$F_c = 2000 \text{mm} * 100 \text{mm} * 410 \text{N/mm}^2$$

$$F_c = 82,000 \text{KN}$$

Then the next is calculating the total power required to cut the work piece NC, which is given by

The formula:-

$$N_c = F_c * \frac{V_c}{6120}, \text{KW} \dots \dots \dots (4.3)$$

Where: F<sub>c</sub>=cutting force

V<sub>c</sub>=cutting speed=0.2m/s recommended for ferrous

$$N_c = 82,000 * 0.2 / 6120$$

$$N_c = 2.68 \text{KW}$$

Then to calculate power rating of the electric motor Nm, which is given by the formula,

$$Nm = \frac{Nc}{\eta} [KW] \dots \dots \dots (4.4)$$

Where:  $\eta$ =coefficient of efficiency drive=0.96 for V-belt  
 $Nm=2.68/0.96=2.79KW$

by considering all the above preconditions motor having, the power of 2.79KW is selected. 1Hp=0.746KW from this formula we get 2.79KW becomes 3.7414Hp. From standard we take 4Hp.

Depending on the selected motor, which has a power of 4HP, is a corresponding revolution per minute of the shaft. This revolution per minutes of the shaft of this standard motor is given by the synchronous speed for an electric induction motor is determined by

The power supply frequency, and the number of poles in the motor winding.

The synchronous speed can be calculated as:

$$N = f * \frac{2}{p} * 60 \dots \dots \dots (4.5)$$

Where:  $N$  = shaft rotation speed (rev/min, rpm)  
 $f$  = frequency of electrical power supply (Hz, cycles/sec, 1/s) =50Hz  
 $p$  = number of poles=2

$$N=50(2/2)*60; N=3000rpm$$

The torque applied by the motor can be calculated by using the power equations,

$$P=T*\omega$$

Where  $p$ =the power of the motor

$T$ =torque of the motor

$\omega$  =angular velocity

$$\omega = (2*\pi *3000)/ (60) =314.159rad/sec$$

$$\text{now; } T=p/\omega =2.233KW (4hp)/366.52$$

$$T=9500Nmm$$

So based on the above specification we select an electric motor having 4HP, 50HZ, 2Poles, 3000rpm and torque of 9500Nmm.

**B. Frame**

**Design analysis of frame**

A structure is called a frame if at least one of its individual members is a multi-force member. A multi-force member is defined as one with three or more force acting on it, or one with two or more forces and one or more coupling acting on it. The frame is used to support and hold the loads arising from vertical and horizontal positions of the total loaded weight as counter balancing. Frames are structures which are designed to support applied loads and are usually fixed in position. These structure members are used to support and balance the total load.

From the material that we select for support frame should have full fill the following properties;  
 Initial cost-cheaper, better Shock absorption, low Maintenance, Good resistance to applied load and Use for long period of time.  
 The material selected for this is plain carbon steel of 25C8 sut =400N/mm<sup>2</sup> and young's modulus 210Gpa.  
 Specifications = 60mm h = 60mm L= 980 mm

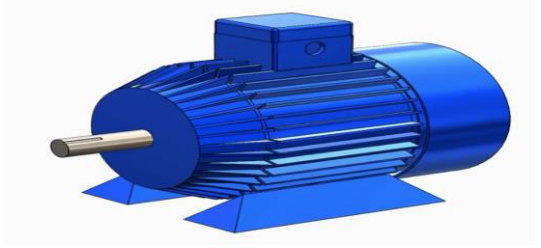

Fig-4: Motor

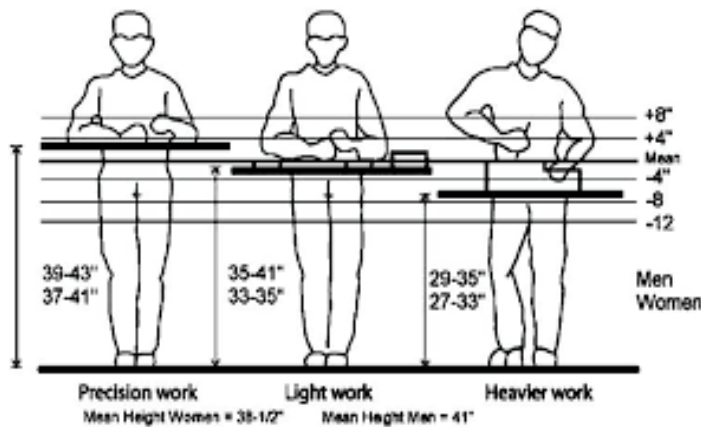

Fig-5: Standard human average height for machines

The crippling load according to Euler's formula,  $Wc = \frac{\text{crushing load}}{1+a/(\frac{L}{k})^2}$

Where,  $L$  = Equivalent length or effective length of the column,  $I$  = inertia of the section,  $E$  = modulus of elasticity  
 $Pc$ = crippling load or buckling load,  $Le$ =equivalent length from table below

Table4.1. Equivalent length

S.no	End conditions	Relation between Equivalent length (L) and actual length(l)
1	Both ends Hinged	$L=l$
2	Both end fixed	$L=l/2$
3	One end fixed and other end hinged	$L=l/\sqrt{2}$
4	One end fixed and other end free	$L=2l$

From the table  $L_e=L/2$ ;  $L_e=2/980=1960\text{mm}$ ,  $I=bh^3/12$ ,  $I = \frac{60 \cdot 60^3}{12} = 1.080 \cdot 10^6 \text{mm}^4$

Then crippling load can be calculated as follows,  $P_c=3.14 \cdot (EI)/L^2$ ,  $P_c = \pi \frac{210 \cdot 1080 \cdot 10^6}{1960^2} = 185.47 \text{KN}$

Where,  $F_s$ =factor of safety=1.5 from standard table ;  $P_s=P_c/F_s$   
 $=185.47/1.5=123.647 \text{KN}$  safe load > design load. Then the design is safe.

**C. Belt:-**

The belts on multi-task machine are used to transmit power from dynamo motor to shafts at the same speed or at different speeds if speed change gear applied.

**Material selection for belt**

In designed machine the material used for belts must be strong and flexible. It must have a high coefficient of friction.

We analyzed that A v-belt is best; having the following advantages over other belt types

- It can easily installed and removed in multi-task machine;
- The operation of the belt and pulley is quite;
- It improves longer life;
- The drive has found to be positive, because the slip between the belt and the pulley groove is very less and it may be negligible.
- There is no joint trouble.

Now the numbers of belts required for given application is given by following equation:

$$\text{No. of belts} = (P \cdot F_a) / (P_r \cdot F_c \cdot F_d) \dots \dots \dots (4.6)$$

Where:  $p$ =drive power to be transmitted (KW)

$F_a$ =correction factor for industrial service

$P_r$ =power rating for single V-belt

$F_c$ =correction factor for belt length

$F_d$ =correction factor for arc of contact

In this application we required a power of the motor is 2.79KW from the above calculation for approximately 12 hours per day.

For 10-16 operational hour per day the correction factor according to service  $F_a=1.3$

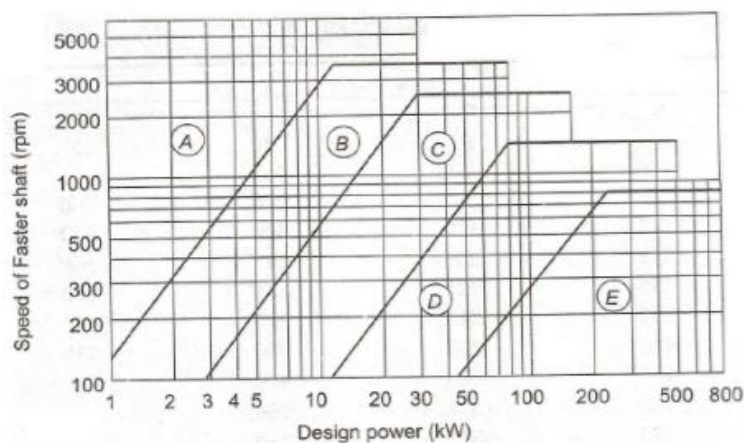

Fig.-6: Design power with speed

$$\text{Design power} = F_a \cdot (\text{drive power to be transmitted})$$

$$P = 1.3 \cdot (2.79 \text{KW}) = 3.627 \text{KW} \dots \dots \dots (4.7)$$

Now Plot a point with coordinates 3.627KW and 3000rpm speed in the above table. It is observed that the point is located in the region of A-section belt.

Therefore, for this application the cross-section of belt is A.

$d=75\text{mm}$  and  $D=200\text{mm}$ .

From table the preferred pitch length for A -section belt is listed; but from the design we take pitch length of belt 890mm. substitute this value of pitch length in the following equation.

$$890 = [3.14(D+d)/2]2C + [(D-d)^2/4C]; C^2 - 409C + 1953.125 = 0; C = 370.04\text{mm}$$

Therefore, the correct center distance is 370.04mm and from pitch length.  $F_c=0.86$ .

Therefore, the angle of contact on the pulley is

$$\text{Angle of contact} = 180 - 2(1/\sin) [(D-d)/2C]$$

Angle of contact = 160.0°

Now from table below by using this angle of contact i.e. 160.0° we can find or select correction factor (F<sub>d</sub>)

Table 4.2. Correction factor for arc of contact (F<sub>d</sub>).

$\frac{D-d}{C}$	Area of contact on smaller pulley(in degrees)	Correction factor
0.00	180	1.00
0.05	177	0.99
0.1	174	0.99
0.15	171	0.98
0.20	169	0.97
0.25	166	0.97
0.30	163	0.96
0.35	160	0.95
0.40	157	0.94
0.45	154	0.93
0.50	151	0.93

Thus, from table above F<sub>d</sub> = 0.95

(2880=3000rpm, 75mm pulley, A-section)(speed ratio 2.66)

Pr=1.42+0.35=1.77KW; No. of belts = (P\*Fa)/Pr\*Fc\*Fd; Therefore, No. of belts = (3.5\*1.2)/1.77\*0.86\*0.95=2.904

No. of belts = 3

This application required only three belts to transmit power.

The coefficient of friction between the belt and the pulley depends upon the following factors:

1. The material of belt;
2. The material of pulley;
3. The slip of belt;
- and 4. The speed of belt.

According to C.G. Barth, the coefficient of friction (μ) for oak tanned leather belts on cast iron pulley, at the point of slipping, is

given by the following relation.  $\mu = 0.54 - \frac{42.6}{152.6 + v}$  Where, v= is belt velocity

Coefficient of friction between belt and pulley will, determined by calculating belt velocity.

$$V = \frac{2\pi * Nr}{60} = \frac{2\pi * 3000 * 0.18502}{60} = 58.126 \text{ m/s } v = 58.126 \text{ m/s but } v \text{ should in m/min, } v = 3487.5 \text{ m/min}$$

$$\text{So, } \mu = 0.54 - \frac{42.6}{152.6 + 3487.5} ; \mu = 0.53$$

The α, for open belt is given by,  $\sin \alpha = \frac{D-d}{2C}$  or  $\alpha = \sin^{-1}(\frac{200-75}{2*370.04})$ , α = 9.72°

The lap angle, Θ of pulley is given by,  $\frac{180-2\alpha}{2} = 80.28^\circ = 1.40 \text{ radians}$

Leather oak tanned with less, μ, than leather chrome tanned is preferable for this machine; while its density is 1000kg/m<sup>3</sup>; Overload factor is 1.5

Dimensions of standard V-grooved pulleys according to IS:

Table 4.3. Dimensions of standard V-grooved pulleys

Type of belt	W	d	a	C	F	e	Grove angle (2β) in degree
A	11	12	3.3	8.7	10	15	32,34,38
B	14	15	4.2	10.8	12.5	19	32,34,38
C	19	20	5.7	14.3	17	25.5	32,36,38
D	27	28	8.1	19.9	24	37	32,36,38
E	32	33	9.6	23.4	29	44.5	-

The angle of groove on the v-belt is 34° from standard (32°, 34°, 38°)

The driving power, p is related with both tensions of the belt as follow,  $p = (T_1 - T_2)V$ ..... (4.8)

And we know,  $2.3 \log \left(\frac{T_1}{T_2}\right) = \mu * \theta * \text{cosec} \beta$ ..... (4.9)

Where; T<sub>1</sub> and T<sub>2</sub> are tension in tight and slack side respectively and, power delivered by motor. But, 2β=34°, so β=17°

From equation (2) we have  $2.3 \log \left(\frac{T_1}{T_2}\right) = 0.53 * 1.40 * \text{cosec} 17^\circ$ ; (T<sub>1</sub>/T<sub>2</sub>) = 12.7; T<sub>1</sub> = 12.7T<sub>2</sub>..... (4.10)

Now substituting equation (3) in to equation (1), we get

$$p = (12.7T_2 - T_2)V; p = 11.7T_2V; 2.79 \text{ KW} = 11.7T_2 * 58.126 \text{ m/s}$$

T<sub>2</sub> = 4.1 Nm and T<sub>1</sub> = 52.10 Nm

Dimensions of standard V-belts according to IS:

Table-4.4: Dimensions of standard V-belts

Types of belt	Power range in KW	Minimum pitch diameter of pulley(d)mm	width(b)mm	(t)mm
A	0.7-3.5	75	13	8
B	2-15	125	17	11
C	7.5-75	200	22	14
D	20-150	355	32	19
E	30-350	500	38	23

Accordinging IS: 2494-1974 dimensions of “A” type v-belt for 75mm pulley diameter are

- Top width, b, =13mm
- Thickness, t=8mm
- width, w=11mm
- d=12mm
- a=3.3mm
- e=15mm
- f=10mm
- Number of sheave grooves(n)=6

❖ Mass of belt, m is given by;

$$= m \cdot b \cdot t \cdot \rho = 0.013 \cdot 0.008 \cdot 0.89 \cdot 1000 \text{ m} = 0.093 \text{ kg/meter}$$

❖ The centrifugal tension between the contact pulley face and belt is given by;  $T_c = mv^2$

$$T_c = \frac{0.093 \text{ kg}}{m} * 58.126^2; T_c = 314.2 \text{ N}$$

So the maximum total tension in the tight side is given by;

$$T_m = T_1 + T_c; T_m = 52.10 \text{ N} + 314.2 \text{ N}; T_m = 366.3 \text{ N}$$

Now the working stress or safe stress can be calculated as follow,

$$\sigma_a = \frac{T_m}{A} = \frac{366.3}{0.013 * 0.008}; \sigma_a = 3.522 \text{ MPa}$$

Now the correction factor or over load factor, c will be;

Having the correction factor the design power,  $P_d$  should be considered to the overload factor for belt design.

$$P_d = 1.5 * P = 1.5 * 2.79 \text{ KW}; P_d = 4.185 \text{ KW}; \text{Where: } P_d = \text{design power.}$$

**D. Pulley**

The pulley used to transmit power to shaft by its grooved like shape and it must in line with the feeder (power source).

**Material selection for pulley**

The pulleys to the multi-task machine may be made of cast iron, cast steel or pressed steel. The cast materials should have good friction and wear characteristics. Due to this we decided select malleable cast iron having a tensile stress of 413.6Mpa and a density of 7300kg/m<sup>3</sup> to achieve this goal.

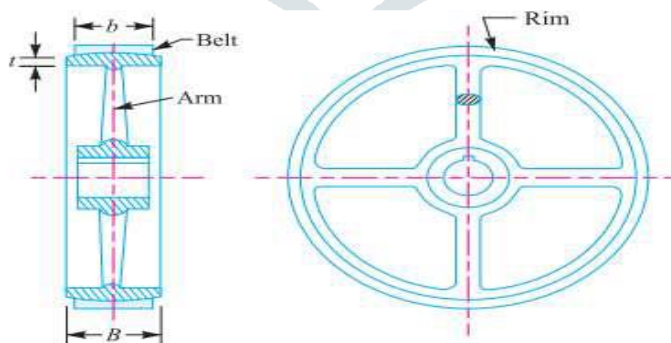

Fig.-7: Solid pulleys

Dimensions of pulley:-

The diameter of the pulley (D) may be obtained either from velocity ratio consideration or Centrifugal stress consideration. The centrifugal stress induced in the rim of the pulley:-

$$\sigma_t = \rho * v^2$$

Where:  $\rho$  = density of the rim material (= 7300 kg/m<sup>3</sup>)

$$v = \text{velocity of the rim} = \frac{\pi DN}{60}$$

Where: D the diameter of pulley and N is speed of the pulleys

$$D = 200 \text{ mm} = 0.2 \text{ m (selected from the table based on type of belt and the required power); } N = 3000 \text{ rpm}$$

Then



$$v = \frac{\pi DN}{60} = 3.14 * 0.075 * \frac{3000}{60} = \frac{3.14*0.075*3000}{60} = 11.8M/s; =7200Kg/m^3; (11.8m/s) = 86KN$$

Since the length of belt that passes over the driver in one minute is equal to the length of belt that passes over the follower in one minute. The speeds of the driven pulleys take N2 = 1200 rpm because the speed of the combine of stem is greater than the speed of the cutting bar. So determining the speeds the diameter of the driven pulleys greater than the drive pulleys,

Therefore;

$$\pi d1N1 = \pi d2N2$$

Then velocity ratio  $\frac{N2}{N1} = \frac{d1}{d2}$ ; Then d2 = = 200mm

The angular velocity of the combine is  $V = \frac{\pi DN}{60} = \frac{3.14*0.2*1200}{60} = 12.57m/s$

According to Indian Standards, IS: 2122 the width of pulley is fixed as given in table below.

If the width of the belt is known, then width of the pulley or face of the pulley (B) is taken 25% greater than the width of belt. . Since the width of the belt is b = 11mm from table below therefore width of the pulley,

Table-4.5: Standard width of pulley

Belt width in mm	Width of pulley to be greater than belt width by (mm)
Up to 125	13
125-250	25
250-375	38
475-500	50

∴ B =

1.25 b; B = 1.25 \* 11 = 13.75mm

Where B = width of pulleys

b= Width of belt.

f = width of pulleys to be greater than belt width (in mm)

So, face of the pulley (B) is taken 25% greater than the width of belt

Therefore B = 13.75 + 13 =26.75mm

Thickness of pulleys:-The thickness of the pulley rim (t) varies from  $\frac{D}{300} + 2mm$  to  $\frac{D}{200} + 3mm$  for single and  $\frac{D}{200} + 6mm$  for double belt. For smaller pulleys; Thickness (t) =  $\frac{75}{200} + 3mm = 3.375mm$ ; Say t = 4mm based on the standard for single

For the larger pulleys; Thickness (t) =  $\frac{200}{200} + 3mm = 4mm$ ; Weight of the driven pulley, wp

WP=mg, and m=ρ\*v, but v=AB

Where, m= mass of pulley=density of pulleys material, A= area and v=volume of pulley So WP=ρ\*A\*B\*  
=7200kg/m<sup>3</sup>\*(π\*(0.2)<sup>2</sup>/4)\*0.035\*9.81= 77.66N

**E. Design of shaft**

Standard Sizes of Transmission Shafts:-The standard sizes of transmission shafts are: 25 mm to 60 mm with 5 mm steps; 60 mm to 110 mm with 10 mm steps; 110 mm to 140 mm with 15 mm steps; and 140 mm to 500 mm with 20 mm steps. The standard lengths of the shaft are 5 m, 6 m and 7 m.

Material selection of shaft

The material used for ordinary shafts is carbon steel of grades 40C8, 45C8, 50C4 and 50C12.

Table-4.6: Mechanical properties of carbon steels used for shafts

Indian standard designation	Ultimate tensile strength, MPa	Yield strength, MPa
40C8	560 – 670	320
45C8	610 – 700	350
50C4	640 – 760	370
50C12	700 Min	390

But we select grade 50C4 because of the following reasons;

Ultimate tensile strength = 700Mpa

Yield strength = 370Mpa

- It should have high strength.
- It should have good machine ability.
- It should have low notch sensitivity factor.
- It should have good heat treatment properties
- It should have high wear resistant properties

Now to calculate the diameter of the shaft the following parameters and calculated values are set first.

Length of shaft L=1200mm (from geometry)

T1=52.10Nm, T2=4.1Nm (from belt design)

Next to this calculate the weight of cutter which is given by the formula, Wb=m\*g

Then;  $m = \rho_{\text{steel}} * V_{\text{circular}}$ ;  $\rho_{\text{steel}} = 7850 \text{ kg/m}^3$  (known)  
 $V = \pi d^2 t / 4$ ,  $d = 250 \text{ mm}$  and for blade diameter;  $t = 2.5 \text{ mm} = 0.0025 \text{ m}$   
 $V = \pi * (0.25 \text{ m})^2 * (0.0025 \text{ m}) / 4 = 0.000122718 \text{ m}^3$ ,  
 $m = 7850 \text{ kg/m}^3 * 0.000122718 \text{ m}^3 = 0.963339934 \text{ kg}$   
 $W_b = 0.96 \text{ kg} * 9.81 \text{ m/s}^2 = 9.45 \text{ N}$

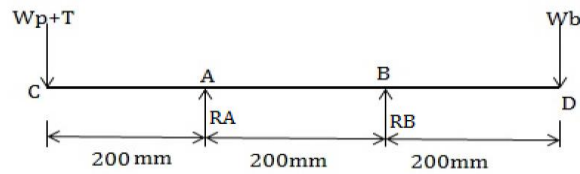

Fig-8: FBD of shaft 1

$\sum F = 0$ ,  
 $RA_v + RB_v = T_1 + T_2 + W_{\text{pulley}} + W_{\text{blade}}$   
 $RA_v + RB_v = (52.10 + 4.1) \text{ N} + 77.66 \text{ N} + 9.45 \text{ N}$   
 $RA_v + RB_v = 143.31 \text{ N} \dots \dots \dots (4.11)$   
 Taking bending moment at point A = 0,  
 $200 RB_v = 26372 \text{ N}$ ;  $RB_v = 132 \text{ N}$   
 $RA_v + RB_v = 143.31 \text{ N}$ ;  $RA_v = 143.31 - 131.86 \text{ N} = 11.5$   
 Bending moment at A

$MA_v = RA_v * 200 + RB_v * 400 = 55100 \text{ Nmm}$

Moment at B =  $RB_v (200) + RA_v (400)$

$= (132 * 200) + (11.5 * 400) = 31000 \text{ Nmm}$ ;  $MA = \sqrt{(MA_v^2 + MA_h^2)} = \sqrt{(55100^2)} = 55100 \text{ Nmm}$

Bending Moment at

$B = \sqrt{(MB_v^2 + MB_h^2)} = \sqrt{(31000^2)} = 31000 \text{ Nmm}$

Bending moment at c and d are zero;  $M_c = M_d = 0$

The resultant B.M diagram is shown in figure above it shows that the bending moment is maximum at A; therefore maximum B.M is = 55100

$$\tau_{\text{max}} = \frac{1}{2} \sqrt{\sigma b^2 + 4\tau^2}$$

$$\tau_{\text{max}} = \frac{1}{2} \sqrt{\left\{ \left( \frac{32M}{\pi d^3} \right)^2 + 4 \left( \frac{16T}{\pi d^3} \right)^2 \right\}} = \frac{16}{\pi d^3 \sqrt{(M^2 + T^2)}}$$

$$\frac{\pi}{16} * \tau_{\text{max}} * d^3 = \sqrt{(M^2 + T^2)}$$

The expression  $\sqrt{(M^2 + T^2)}$  is known as equivalent twisting moment and is denoted by  $T_e$ ;

$T_e = \sqrt{M^2 + T^2} = \frac{\pi}{16} * \tau * d^3$

$T = \sqrt{(T_1 - T_2)R} = (52.10 - 4.1) \text{ N} * 200 \text{ mm} = 9600 \text{ Nmm}$

Shear maximum =  $S_{sy} / F_s = 0.5 * S_{yt} / 3 = 0.3 S_{yt} = 0.3 * 370 \text{ Mpa}$

$T_e = \sqrt{(M^2 + T^2)} = \sqrt{(55100^2 + 9600^2)^{1/2}} = 55930.05 \text{ Nmm}$

$T_e = \pi / 16 * \tau * d^3 = 16 T_e / (\pi * \tau) = d^3$

$d = \sqrt[3]{(16 T_e / (\pi * \tau))} = \sqrt[3]{\left\{ \frac{(16 * 55930.05 \text{ Nmm})}{(\pi * \tau)} \right\}}$

$d = 29.59$  say standard value  $d = 30 \text{ mm}$  and also according to maximum normal stress theory, the maximum normal stress in shaft.

$\sigma_{b\text{max}} = \frac{1}{2} \sigma_b + \frac{1}{2} \sqrt{\sigma_b^2 + 4\tau^2} = \frac{1}{2} * \frac{32M}{\pi d^3} + \frac{1}{2} \sqrt{\left\{ \left( \frac{32M}{\pi d^3} \right)^2 + 4 \left( \frac{16T}{\pi d^3} \right)^2 \right\}} = \frac{32}{\pi d^3} \left[ \frac{1}{2} (M \sqrt{M^2 + T^2}) \right]$   
 $\frac{\pi}{32} * \sigma_{\text{max}} * d^3 = \frac{1}{2} [M + \sqrt{M^2 + T^2}]$

Equivalent bending moment  $M_e = \frac{1}{2} [M + \sqrt{M^2 + T^2}] = \frac{\pi}{32} * \sigma_{\text{max}} * d^3$

$555150.23 = \frac{\pi}{32} * \frac{466.67 \text{ N}}{\text{mm}^2} * D = \sqrt[3]{12123.3} = 22.97 \text{ mm} \approx 24 \text{ mm}$

Taking the large of the two value we have  $d = 30 \text{ mm}$ .

$\sum F_y = 0$

$RA_y + RB_y = 0$

$T = T_1 \cos \theta + T_2 \cos \theta = 52.1 \cos 30 + 4.1 \cos 30 = 48.67 \text{ Nmm}$

$RA_y + RB_y = 48.67 \dots \dots \dots (1)$

Taking Bending moment at A

$1200 RB_y = 48.67$ ;  $RB_y = 0.04 \text{ N} \dots \dots (2)$

$RA_y + RB_y = 48.67$ ;  $RA_y = 48.67 - 0.04 = 48.63 \text{ N}$

Section  $0 < X < 200$

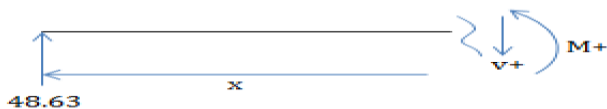

$M = 48.63x \dots \dots \dots (4.12)$

When at  $x = 0$ ;  $M = 0$

At  $x = 200$ ;  $M = 9726 \text{ Nmm}$

Section  $200 < x < 1200$ ;  $M + 48.67 + (x - 200) - 48.63x = 0$ ; At  $x = 200$ ;  $M = 48.63 * 200 = 9726 \text{ Nmm}$

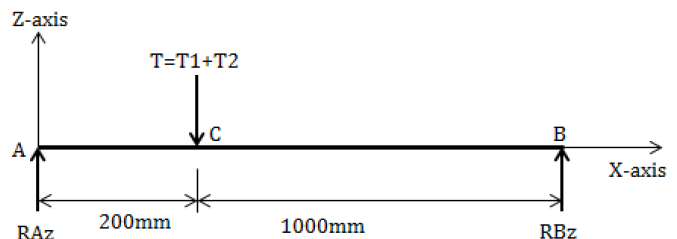
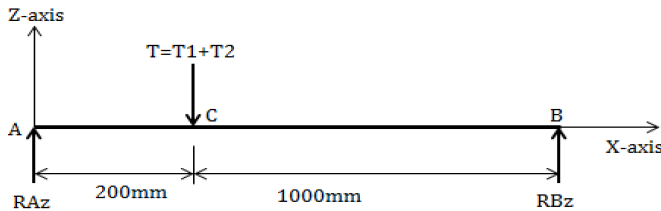

Fig-9: .FBD for shaft 2

At X=1200;  $M+48.67(1000)-48.63*1200=0$   
 $M+48670-58356=0$ ;  $M=9.686\text{Nmm}$



$\sum Fz = 0$ ;  $RAy+RBy=T$ ;  $T=T1\sin\theta+T2\sin\theta=52.1\sin30+401\sin30 =28.1\text{Nmm}$

$RAz+RBz=28.1$ .....”(4)”

Bending moment at A

$-28.1+RBz(1200)=0$ .....”(5)”

$1200RBz=28.1$ ;  $RBz+RBz=28.1$ ;  $RAz=28.076\text{N}$

Section  $0 < X < 200$ ;  $M=28.070X$ .....(4.13)

At  $X=0$ ;  $M=0$ ; At  $X=200$ ;  $M=5615.32\text{Nmm}$

Section  $200 < X < 1200$ ;  $M+28.1(X-200)-28.070*X=0$

At  $X=200$ ;  $M=28.07(200) =5614\text{Nm}$

At  $X=1200$ ;  $M+28.1(1000)-28.070*1200=0$

$M+28100-33684=0$ ;  $M=5.584\text{Nmm}$

From the above calculation maximum moment is at point  $M_cR = \sqrt{MCy^2 + MCz^2}$   
 $= \sqrt{(9726)^2 + (5614)^2} = 11229.96\text{Nmm}$   
 $T_t = \sqrt{T_y^2 + T_z^2} = \sqrt{(48.67)^2 + (28.1)^2}$   
 $T_t = 56.1996$

$T_e = \sqrt{(M^2 + T^2)} = \frac{\pi}{16} * \tau * d^3 = \sqrt{(11229.96)^2 + (56.199)^2} = \frac{\pi}{16} * 111\text{Mpa} * d^3$

$112301.0 = \frac{\pi}{16} * 111\text{Mpa} * d^3$   
 $d^3 = \frac{112301.0 * 16}{111 * \pi}$ ;  $d = \sqrt[3]{\frac{112301.0 * 16}{111.0 * \pi}}$

$d=17.279\text{mm}$  to the standard 22mm

According to maximum normal stress theory

$\delta b_{max} = \frac{1}{2} * (\frac{32M}{\pi d^3}) + \frac{1}{2} \sqrt{((\frac{32M}{\pi d^3})^2 + 4(\frac{16T}{\pi d^3})^2)}$

Equivalent bending moment  $M_e = \frac{1}{2} ( M + \sqrt{(M^2 + T^2)} ) = \frac{\pi}{32} * \delta b * d^3$

$= \frac{1}{2} (11229.96 + \sqrt{(11229.96)^2 + (56.199)^2}) = 11230 = \frac{\pi}{32} * \delta b * d^3$

$d^3 = \frac{112300 * 32}{\delta b * \pi} = \frac{11230.0 * 32}{466.67 * 3.14}$ ;  $d = \sqrt[3]{\frac{112300 * 32}{466.67 * 3.14}}$ ;  $d=13.48$

Comparing the diameter of equivalent twisting moment and maximum normal stress theory (equivalent bending moment we take the maximum diameter  $d=22\text{mm}$ ).

**F.Design and selection of key**

A key is a piece of mild steel in the designed machine it inserted between the shaft and hub which aimed to prevent rotating shaft and pulley from leaking.

The selection of the type of key for the designed machine application depends upon the following factors.

- ❖ Power to be transmitted
- ❖ Tightness of fit
- ❖ Stability of connection and cost

Depending on these applications we select rectangular sunk key.

Given data;

- ❖ Shaft diameter=22mm
- ❖ Key material mild steel having the following specifications
- ❖ Shear stress,  $\tau=111\text{Mpa}$  and crushing stress,  $\sigma_c=70\text{Mpa}$
- ❖ For motor and cutter shaft two keys are needed at both ends of the pulley

From the table property of the standard parallel tapered and gibe head keys at shaft diameter of 22mm,  $w=8\text{mm}$  and  $t=7\text{mm}$ ;

The length of key is obtained by considering the key in shearing and crushing.

Let  $L$ = Length of key. Considering shearing of the key, we know that shearing strength (or torque transmitted) of the key,

$= \frac{L * W * \tau * d}{2}$ ,  $T=561990\text{Nmm}$

$T L = 561990 * 2 / (8 * 111 * 22) = 28\text{mm}$

Now considering crushing of the key, we know that shearing strength (or torque transmitted) of the key,

$$T = \frac{L \cdot t \cdot \sigma_c \cdot d}{2} = 561990 \cdot 2 / (7 \text{mm} \cdot 70 \text{Mpa} \cdot 22 \text{mm}) = 20.85 \text{mm}$$

Taking larger of the two values, we have length of key, L=28mm (for cutter shaft and driven pulley)

To calculate key of motor shaft and driving pulley, we select width and thickness of key from table for motor shaft=20mm, w=8mm, t=7mm, next to this we can calculate length of key same to the above.

By considering shearing of key length of key is calculated as,

$$L = 561990 \text{Nmm} \cdot 2 / (8 \cdot 11 \cdot 22), T_{\text{motor}} = 19.7 \text{Nm} \Rightarrow 22 \text{mm}$$

By considering crushing of key length of key is calculated as,

$$L = 561990 \text{Nmm} \cdot 2 / (7 \text{mm} \cdot 70 \text{Mpa} \cdot 22 \text{mm}); = 17.5 \text{mm}, \text{ then we take the larger value of the two,}$$

L=22mm (for motor shaft and driving pulley)

**G. Design of a Saw Blade**

Similar blades are being used by operators and the industry, and despite their simple appearances is a fairly refined technology. The Technical requirements were made taking into consideration the following aspects:

- Compatibility with existing machines in the market (parameters like blade diameter, collar diameter, no. of teeth)
- Reliability of the Blade (blade material)
- Cutting performance of the (tooth profile with optimized bevel angle, rake angle, minimum de-lamination of the wood work piece, and straightness of cuts).

Table-4.7: Technical Requirements of the Blade

parameter	Standard blade	Blade 1	Blade 2
Blade diameter	127mm	127mm	127mm
No of teeth	40	40	40
Bevel angle	50	100	150
Rake angle	90	110	130
Clearance angle	80	100	120
Length of piece of cut	203.2mm	203.2mm	203.2mm
Thickness of piece	19.05mm	19.05mm	19.05mm
Straightness of cut	Good	good	Good
Quality of cut(de-lamination)	acceptable	best	Good

The parameters important from a design point of view are shown in the Figure below.

- B-----bore diameter
- C-----Hook angle -5° up to 30°
- D-----Blade diameter (typical) 10<sup>11</sup> to 30<sup>11</sup> concentrating on 1811
- E-----Expansion slot hook angle -20° to 20°
- F-----Ramp angle 10° to 75° (30° typical)

The design of the blade tooth profile was carried out considering the above parameters.

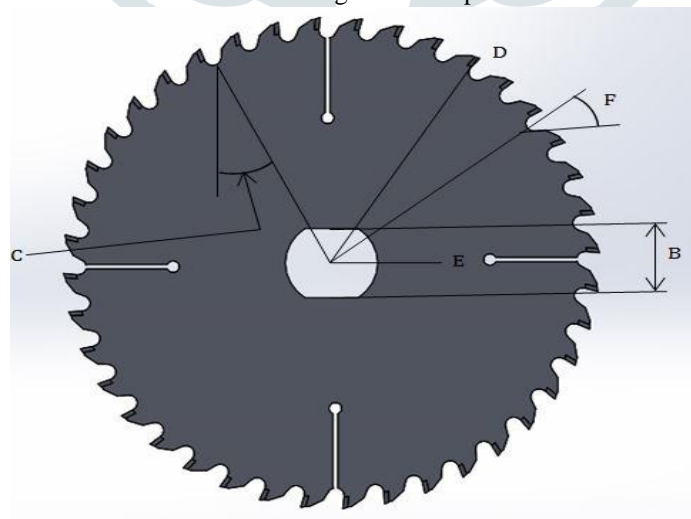

Fig-10: Parameters important in saw blade design

Table-4.8: Tooth Profile Parameters of specially manufactured Blades

Parameter	Unit
Blade Diameter	125-127 mm
Mass	120-140 gm
Collar Diameter	1 inch
No. of teeth	38-42 nos.

Blade Material	HSS Steel-ASTM L6
Young's Modulus	2.1e+011N/m2
Bevel Angle	-5 <sup>0</sup> to + 30
Rake Angle	-5 <sup>0</sup> to + 30
Clearance Angle	-5 <sup>0</sup> to + 30

**H. Design and Selection of Bearing**

A bearing is a machine element which supports another moving machine element it permits a relative motion between the contact surfaces of the members, while carrying the load. In our design bearings are used at the cutter shaft or on frame used to support the rotating shaft by preventing wear. The selected type of bearing is radial ball bearing. A number of balls are used and these are held at proper distances by retainers so that they do not touch each other. The retainers are thin strips and usually in two parts which are assembled after the balls have been properly spaced.

Material selection for bearing Since the rolling elements and the races are subjected to high local stresses of varying magnitude with each revolution of the bearing, therefore the material of the rolling element (i.e. steel) should be of high quality. The balls are generally made of high carbon chromium steel. The material of both the balls and races are heat treated to give extra hardness and toughness.

We select roller bearing for our design. The contact between the bearing surfaces is rolling by the following merits,

- ❖ Accuracy of shaft alignment
- ❖ Reliability of service
- ❖ Low cost of maintenance, as no lubrication is required while it is in service.
- ❖ Small overall dimension
- ❖ Ability to with stand momentary shock loads
- ❖ Clean lines
- ❖ Easy to mount and erect

In order to select a most suitable ball bearing, first of all, the basic dynamic radial load is calculated. After finding the design basic dynamic radial load capacity, the selection of bearing is made from the catalogue of a manufacturer. Let us see the analysis, the torque acts on shaft is 56199Nmm.

The load acts radial on holder shaft,

$$P=T/r \text{ where; } r=\text{length of shaft } =1200\text{mm for our design; } P = 56199/1200=46.83\text{N}$$

For radial load = 46.83 N at 3000rpm for 10hours per day, then expected life of bearing (L<sub>10</sub>hrs) is equal to 25000 hrs.

The relationship between life in million revolutions and life in working hours is given by: -

$$L_{10} = \frac{60nL_{10h}}{10^6} ; \text{Where, } L_{10h}=\text{rated bearing life (hours)} =25000\text{hrs; } n= \text{speed of rotation (rpm)} =3000\text{rpm}$$

$$L_{10} = \frac{60nL_{10h}}{10^6} = 60*3000\text{rpm}*25000\text{hrs}/10^6= 4500\text{million revolutions}$$

The relationship between the dynamic load carrying capacity(C), the equivalent dynamic load (P) and the rated bearing life ( L<sub>10</sub> ) is given by:  $L_{10}=(c/p)^3$

By rearranging the equation  $C=P (L_{10})^{1/3}=46.83(825)^{1/3}= 439.2\text{N}$

439.2N which is less than 4KN, hence the nearest force (basic dynamic load rating) from standard table may be 4KN with the bearing number 212 is selected.

With this load and bearing number: Bore=60mm

Outer side diameter =110mm and Width= 22mm

The static load rating is given in bearing catalog tables. It comes from the equations.

$$C_0 = M * n_b * d_b^2 \dots\dots \text{(Ball bearings) and } C_0 = M * n_r * l_c * d \dots\dots \text{(Roller bearings)}$$

Where: C<sub>0</sub>= bearing static load rating, lbf (kN)

n<sub>b</sub>= number of balls; n<sub>r</sub>= number of rollers; d<sub>b</sub>= diameter of balls, in (mm)

d = diameter of rollers, in (mm); l<sub>c</sub>= length of contact line, in (mm) And M takes on the values of which the following table is representative:

Table-4.9: parameters to find static load rating

M	in and lbf	mm and KN
Radial ball	1.78*(10) <sup>3</sup>	5.11(10) <sup>3</sup>
Ball thrust	7.10(10) <sup>3</sup>	20.4(10) <sup>3</sup>
Radial roller	3.13(10) <sup>3</sup>	8.99(10) <sup>3</sup>
Roller thrust	14.2(10) <sup>3</sup>	40.7(10) <sup>3</sup>

$$C_0 = 20.4 * 10^3 * 13 * 0.11^2 = 3.2\text{KN}$$

**I. Design analysis of table**

**Material selection**

Material is selected based on properties such as high bending & tensile strength, ease of availability, ease of machining, welding, finishing, cutting etc. and cost factor. For table, support column and support plate will use plain carbon steel 25c8.

Material Properties of 25c8, Tensile strength,  $\delta t = 390\text{N/mm}^2$ , Elastic modulus,  $E=210\text{Gpa}$

Table specifications;  $L=1200\text{mm}$ ;  $W=1000\text{mm}$

Total load acting on table= (mass of adjusting lever + mass of working material) gravity=  $(4\text{k.g}+200\text{k.g})\cdot 9.81=2001.24\text{N}$

$$M = \frac{Wl^2}{8} = \frac{(2001.24 \cdot (1200\text{mm}^2))}{8} = 2471625.3\text{Nmm}; \text{ Moment of inertia, } I = \frac{bt^3}{12} = \frac{1000\text{mm}^3}{12} = 83.33\text{t}^3$$

$$\sigma_{all} = \frac{Syt}{Fs} = \frac{390}{2.5} \text{ From bending stress } \frac{2471625.3\text{Nmm}}{83.33\text{t}^3} = \frac{156}{t}; t^2 = \frac{2471625}{6500} = 380.25 = 19.5$$

Say standard value 20mm

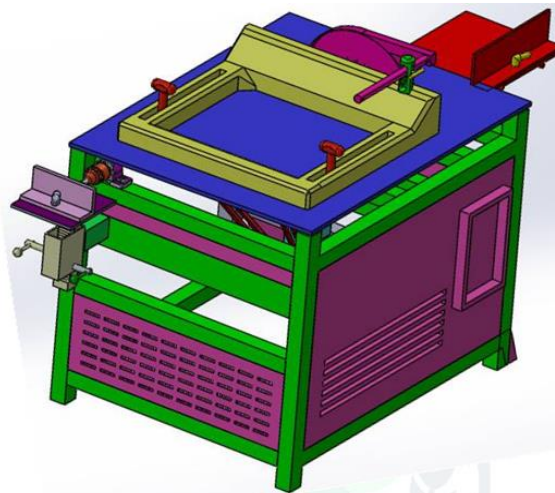

Fig-11: Assembled Drawing

**V. RESULT AND CONCLUSION**

**5.1. Result**

Since our objective is to design motor driven multi-task metal, wood and plastics machine, we designed all parts of the machine, the mathematical modeling and structural and transient analysis of all parts and the resulting dimensions of parts are listed. From the structural analysis of parts, we can observe that where the load is concentrated and the point where failure occurs. As a result, there is no any failure of parts that the machine can perform the operation; to avoid the problems discussed at the beginning of this project.

The machine has the following dimensions:

- Length of table=1200mm , Width of table=1000mm, Overall height of machine=1100mm
- Total load acting on table=(mass of adjusting lever + mass of working material)gravity =  $(4\text{k.g}+200\text{k.g})\cdot 9.81=2001.24\text{N}$

- based on the calculation we select an electric motor having 4HP, 50HZ, 2Poles, 3000rpm and torque of 9500Nmm

So the height of the machine is proportional to the human height which is easy to operate. The mass is also in at safe range. When it has such appropriate mass, it prevents vibration of the machine.

Geometric specifications of material are:-

- Material to be cut mild sheet metal, wood, metal and plastic
- Maximum diameter of work piece to be done= 300mm (round)
- Maximum length of work piece to be done=2000mm , Maximum thickness of the work piece = 100 mm.

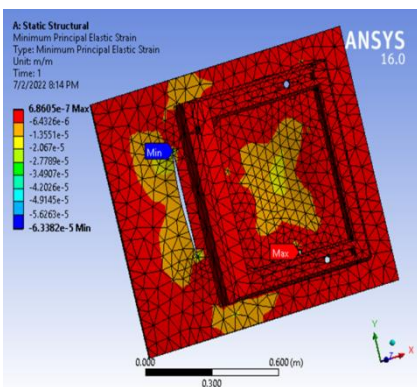

Fig-12. Minimum principal strain

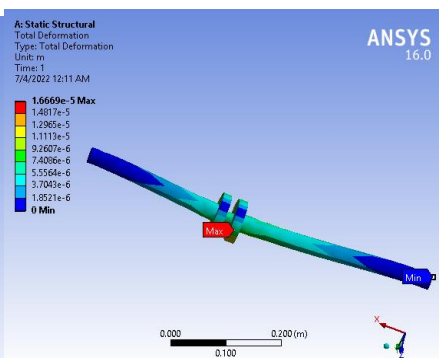

Fig-13: Total deformation on shaft 2

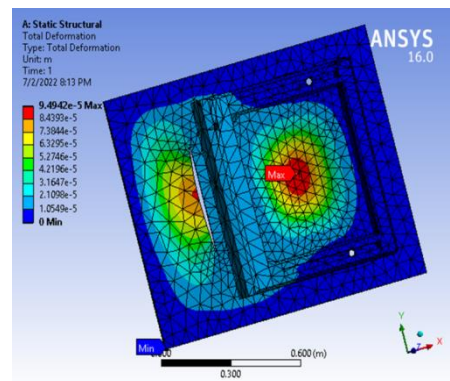

Fig-14. Total deformation

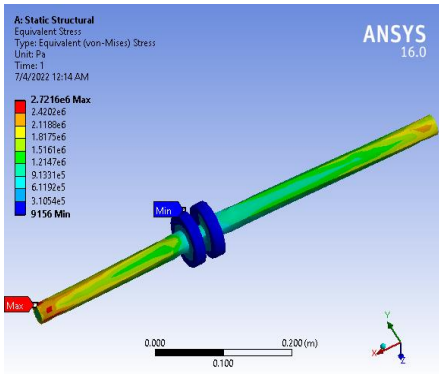

Fig-15: Equivalent (von-mises) stress.

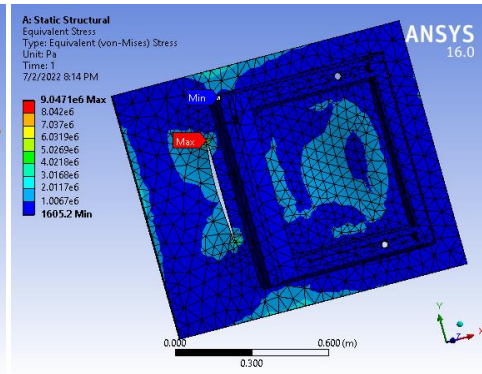

Fig-16: Equivalent (Von-mises) stress

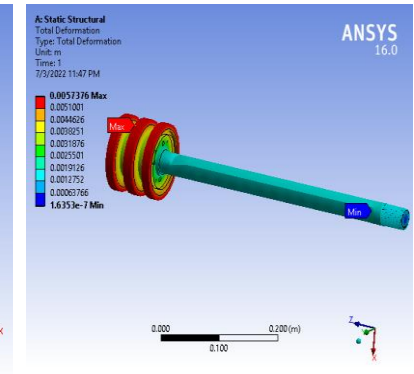

Fig-17: Total deformation shaft 1.

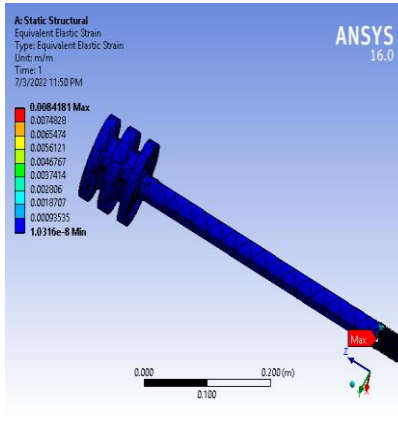

Fig-18: Equivalent elastic strain

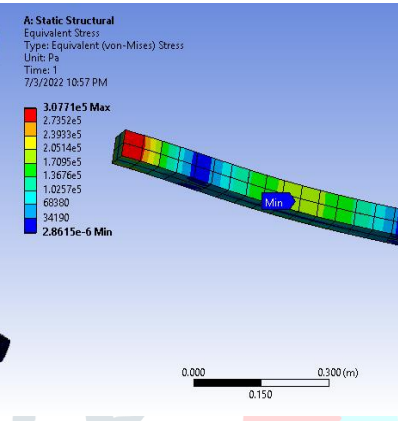

Fig-19: Equivalent (Von-mises) Stress.

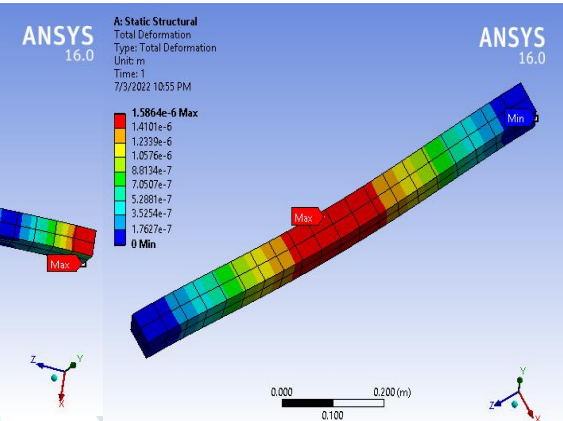

Fig-20: Total deformation on machine bar

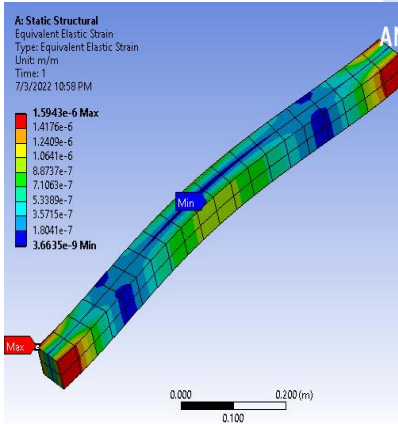

Fig-21: Maximum principal stress.

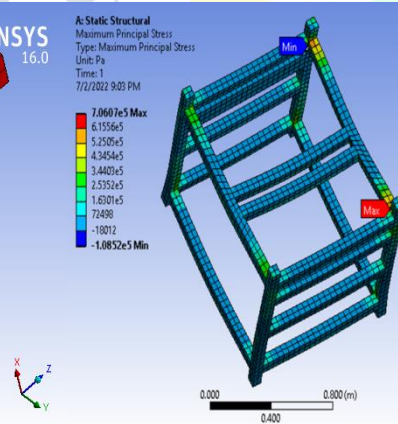

Fig-21: Equivalent Elastic Strain.

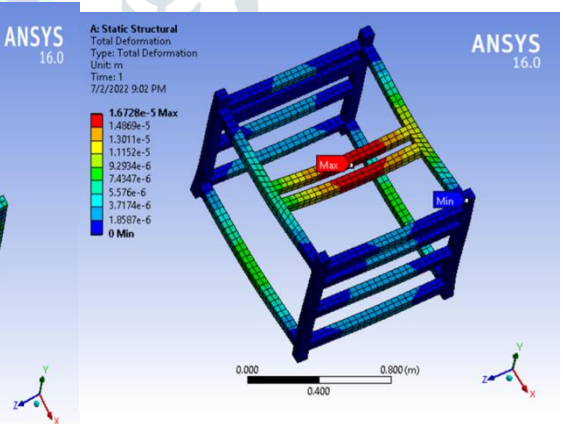

Fig-22: Total deformation

**5.2. Conclusion**

The scope of the project was to enhance productivity of furniture, ceramic, plastic and wood working machine and making cost as low as possible. Therefore with this design it can applicable for practical use to satisfy the anticipated task in improving development. Since wood, plastics and metals are widely used in many application areas like metal industries, workshops, garages etc. Now a day machines like hacksaw, power hacksaw, abrasive saw etc., are used to cut woods but they were not well designed and qualified cutting operation. By considering this pneumonia, we have tried to design and analyze the best machine to solve the problems. The machine has effective performance that reduces the faced problems.

Generally we conclude that, the lack of wood, ceramics and metal will be solved as much as possible with the designed machine. Because of the machine has basic features such as simple to operate easy to deliver to rural area operate with different operations.

**REFERENCES**

[1].History of the circular saw. [Online] Available at: (<https://www.yorksaw.com/history-circular-saw/> [Accessed 11 February 2020].  
 [2]. Anthony, Paul. Taunton's complete illustrated guide to table saws. Newtown, CT: Taunton Press, 2009  
 [3]. R.S, KHURMI, J.K. GUPTA, A text book of Machine Design, Eurasia publishing house pvt, L, 2005 New Delhi  
 [4].Hibbeler, R., 1997. Column Buckling: Design using Euler Theory. In: R. Hibbeler, ed. Mechanics of Materials. 3rd ed.

Englewood Cliffs: Prentice Hall.

[5].Blade Terminology, Tooth Forms & Tooth Set (<http://www.spectrumsupply.com/pdf/bladeterminology.pdf>)

[6].Tool Engineering and Design G.R.NAPAL.Khurmi R, S. G. J., 2005. A textbook of machine design. NEW DELHI

[7].Technology Comparison of Motion Detectors. [Online] Available at: <http://www.ecosirius.com/technology.html>.

[8].Patani, S. P., 2007. AN ATTEMPT TO IMPROVE SAFETY SYSTEM, Unjha: Dabhi.

[9]. Bosch, R., 2009. Power Tools for Professionals. [Online] Available at: <https://www.boschtools.com/ca/en/boschtools-ocs/table-saws-4100-30445-p/>[Accessed 15 january 2020]

[10]. Khurmi, R. S. a. G. J. K., 2005. a textbook of machine design. 14 ed. RAM NAGAR, NEW DELHI-110 055: EURASIA PUBLISHING HOUSE (PVT.) LTD.

