

# USER DEPENDENT VOICE RECOGNITION HOME AUTOMATION

<sup>1</sup>Mr. K. Pavan Kumar, <sup>2</sup>C. Mani Kumar, <sup>2</sup>S. Sairam Reddy, <sup>2</sup>S. Teja

<sup>1</sup>M.Tech Assistant Professor, <sup>2</sup>Pursuing B. Tech

Dept of ECE,

GITAM(Deemed to be University) Hyderabad.

## Abstract

Old aged or disabled persons who can't walk are most sensitive persons and they must be served in a systematic, quick, sophisticated and efficient manner by very little effort. The problem is that there is no anybody who is always with them for 24 hours. Speech recognition can be used to serve the old aged or disabled persons and to give a full control to them so that they may control all the appliances of home. Traditional home automation systems are not cost effective and they are not suitable for aging populations or disabled persons. The project aims in designing a system which is capable of switching ON/OFF the electrical devices based on the user dependent voice (command). This system creates a new era in the automation system. This system integrates human-machine interface.

**Keywords:** MATLAB, PIC microcontroller, Relays, USBTTL.

## 1. INTRODUCTION

The home automation systems are gaining popularity day by day due to their ease of use and wide operations capabilities. Integrating voice recognition technology to home automation systems make the system more user friendly and easy to operate. Some require home automation system to satisfy their needs and comfort while for physically challenged people it can provide great assistance.

The home automation systems are gaining popularity day by day due to their ease of use and wide operations capabilities. Integrating voice recognition technology to home automation systems make the system more user friendly and easy to operate. Some require home automation system to satisfy their needs and comfort while for physically challenged people it can provide great assistance.

This project presents an effective method to overcome these problems. We have designed and implemented a low-cost, reliable, efficient and secure speech operated system for home appliances especially for persons with disabilities to do their work at home. This system is both software and hardware designed using MATLAB and PIC Microcontroller. This system used by the user dependent voice recognition dependent method. This proposed design is novel in the way that it is controlling loads by voice recognition using MATLAB to turn on/off loads through PIC microcontroller.

## 2. LITERATURE SURVEY

Several techniques and methods are available for Home automation system. The common methods are given as:

### 1. Home Automation System using GSM Technology

This system provides a modern era automation system where we can monitor and control the status of the appliances from anywhere in the world. Here the devices to be controlled are interfaced to Arduino Microcontroller unit through switches Relay and controller which receives SMS through GSM modem interfaced to it, processes them and performs appropriate action on the devices.

### 2. Advanced home automation system controlled by RF

The device consists of a microcontroller, which is interfaced with the input and output modules, the controller acts as an intermediate medium between both of them. So the controller can be termed as a control unit. The input module is nothing a switch board to which RF transmitter is interfaced. When the user presses a switch the data will be transmitted over RF transmitter. The data will be received by the RF receiver and is fed to controller. The Microcontroller acts accordingly to program and switches the Relays to which electrical devices to be operated are connected. The Microcontroller used in the project is programmed using Embedded 'C' language.

### 3. Bluetooth and Zigbee based Home automation based on Android

The input and output port of the controller are interfaced with different input and output modules depending on the requirements. In other words micro controller acts as a communication medium for all the modules involved in the project. In this project we make use of a pair of zigbee in which one is at transmitted section connected to Bluetooth takes input from mobile and other is at receiver section connected to micro controller, Bluetooth Modem, Micro Controller and relay circuit. In this project device controlling is done by text message of android application through Bluetooth and zigbee that is connected to the Microcontroller based control system. The microcontroller automatically reads the message from receiver zigbee through Bluetooth operates the devices using relays. This process continues for every new message we send to it. The previous message will be automatically overridden by new message and LED indication is given for every new message.

#### 4. DTMF Based Home Automation

This system is designed to provide control of home appliances through landline/mobile phone by dialing the designated number for the particular load. Dialing can be done from the home phone or a call made to the home number from outside. This system is designed without engaging a programmable microcontroller but is based on digital logic using DTMF technology (Dual Tone multiple frequency) which receives the command from the landline phone /mobile phone to develop digital output.

#### 5. IOT BASED HOME AUTOMATION

This project aims at controlling home appliances via Smartphone using Wi-Fi as communication protocol and microcontroller as server system. The user here will move directly with the system through a web-based interface over the web, whereas home appliances like lights, fan, are remotely controlled through easy app

#### 3. Implementation:

User Depended Voice Recognition Home Automation

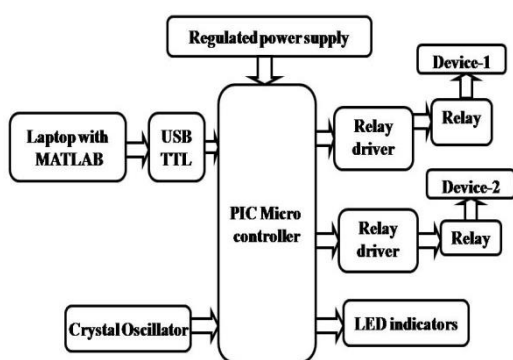

The controlling device of the whole system is a Microcontroller. Laptop with MATLAB along with USBTTL, 2 Relays is interfaced to the Microcontroller. Whenever user speaks his/her command (already defined) with laptop microphone. The MATLAB code is running inside the laptop and the user voices recognize it, if it is matched with already define voice and feeds this as input to Microcontroller. The Microcontroller processes this information and switches on/off the loads through relays. Here relays works as a switch to on/off the electrical devices. The Microcontroller is programmed in Embedded C language

#### 4 Related works:

#### MATLAB:

MATLAB is a high-performance language for technical computing. It integrates computation, visualization, and programming in an easy-to-use environment where problems and solutions are expressed in familiar mathematical notation.

MATLAB is a language designed for mathematical and scientific purposes that has plenty of tools to deal with most areas of Maths and Science. It makes it possible to write programs rapidly as the constraints imposed by other languages aimed for developing commercial software are not there.

All MATLAB numeric types in the 32-bit and 64-bit versions of MATLAB are the same size, providing broad consistency between the two. At the lowest level of operation, however, a 32-bit and 64-bit application may use CPU registers of differing widths, which can result in slightly different answers due to round-off effects. This effect can be more pronounced when working with data of type single. The differences are unimportant in many applications, but re-examine any application with a high sensitivity to numerical results when transitioning to the 64-bit version of MATLAB. In this project we are using 2018 64-bit MATLAB for accurate results.

#### Key Features of MATLAB:

- High-level language for scientific and engineering computing.
- Desktop environment tuned for iterative exploration, design, and problem solving.
- Graphics for visualizing data and tools for creating custom plots.
- Apps for curve fitting, data classification, signal analysis, and many other domain-specific tasks.
- Add-on toolboxes for a wide range of engineering and scientific applications.
- Tools for building applications with custom user interfaces.
- Interfaces to C/C++, Java®, .NET, Python®, SQL, Hadoop®, and Microsoft® Excel®.
- Royalty-free deployment options for sharing MATLAB programs with end users.

#### Relay:

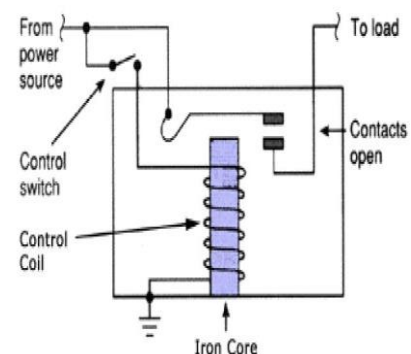

Relays are simple switches which are operated both electrically and mechanically. Relays consist of an electromagnet and also a set of contacts. The switching

mechanism is carried out with the help of the electromagnet. There are also other operating principles for its working. But they differ according to their applications.

### USB-TTL Converter:

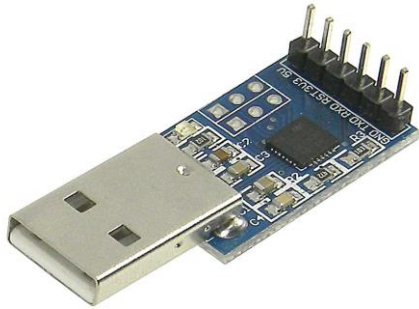

The CP2102 includes a USB 2.0 full-speed function controller, USB transceiver, oscillator, EEPROM, and asynchronous serial data bus (UART) with full modem control signals in a compact 5 x 5 mm MLP-28 package. No other external USB components are required.

### Features

- Single-Chip USB to UART Data Transfer
- Integrated USB transceiver; no external resistors required
- Integrated clock; no external crystal required
- Integrated 1024-Byte EEPROM for vendor ID, product ID, serial number, power descriptor, release number, and product description strings
- On-chip power-on reset circuit
- On-chip voltage regulator: 3.3 V output
- 100% pin and software compatible with CP2101
- USB Function Controller
- USB Specification 2.0 compliant; full-speed (12 Mbps)
- USB suspend states supported via SUSPEND pins
- Virtual COM Port Device Drivers

### 5. RESULTS:

The implementation of **USER DEPENDENT VOICE RECOGNITION HOME AUTOMATION** is done successfully.



### 6. CONCLUSION

The designed voice operated system is a low-cost, reliable, efficient and secure. The designed voice Operated system can be used in various areas of application. Voice

operated system can also be used to answer computers in a hands-free environment, like when driving. voice operated system can be used in tasks that require human-machine interface, for example automatic call processing in the telephone network and data query information systems. The system has two main parts: voice recognition and smart home appliances electronic control system. voice recognition is implemented in MATLAB environment. An application for voice command processing is developed.

### 6. ACKNOWLEDGEMENT

We would like to thank all the authors of different research papers referred during writing this paper. It was very knowledge gaining and helpful for the further research to be done in future.

### REFERENCES

- [1] B.H. Juang & Lawrence R. Rabiner, Automatic Speech Recognition – “A Brief History of the Technology Development”.
- [2] Coucopoulos, Andre; 2007, “Voice processing for home automation systems”, Network system design line, January 2007.
- [3] Gnanasekar. A.K, Jayavelu.P, Nagarajan.V, “Speech Recognition Based Wireless Automation of Home Loads with Fault Identification”, IEEE International conference on communications and signal processing (ICCSP), Vol. 3, pp.128-132, 2012.
- [4] Jie Liu, Jigui Sun, Shengsheng Wang, “Pattern Recognition: An overview”, IJCSNS International Journal of Computer Science and Network Security, vol. 6, no. 6, June 2006.
- [5] LA Roberts, HT Nguyen, EM Silver, “Gesture Activated Home Appliance” - US Patent 6,937,742, 2005 - Google Patents
- [6] M.A. Anusuya, “Speech Recognition by Machine,” International Journal of Computer Science and Information security, Vol.6, No.3, 2009.