

THREE PHASE FOUR WIRE BASED SHUNT ACTIVE POWER LINE CONDITIONER (SAPLC) TO COMPENSATE THE NEUTRAL CURRENT & POWER QUALITY

¹Prateek Sharma, ²Nishi Singh

¹Research Scholar Mtech. Power Systems, ²Assistant Professor,
^{1,2}Department of Electrical and Electronics Engineering,
^{1,2} Rabindranath Tagore University, Bhopal-Chiklod Road, Raisen-464993(M.P)

Abstract: The term electric power quality broadly refers to maintaining a nearly sinusoidal power distribution bus voltage at rated magnitude and frequency. In addition, the energy supplied to a consumer must be uninterrupted from reliability point of view. This research work have three phase four wire based Shunt Active Power Line Conditioner (SAPLC) to compensate the neutral current produce by the unbalanced system as well as the improve the power quality of the distribution system in power grid.

Introduction

Over the past few years, the enormous increase in the use of non-linear loads arises many power quality issues like high current harmonics, voltage distortion and low power factor etc. on electrical grid [1]. Hence the proliferation of non-linear load in system generates harmonic currents injecting into the AC power lines. This distorted supply voltage and current causes malfunction of some protection devices, burning of transformers and motors, overheating of cables. Hence it is most important to install compensating devices for the compensation of harmonic currents and voltages produced due to nonlinear load. Traditionally, passive power filters have been used as a compensating device, to compensate distortion generated by constant non-linear loads.

Power Quality Solutions

Modern customers uses nonlinear loads induces the appearance of the damaging development of power quality problems among the electrical feeder networks, producing distortions inside the current/ voltage waveforms.

Passive Filters

Power line conditioner imagined to boost the quality of the power that is delivered to the load equipment. Conventionally, the foremost common methodology used for mitigation of harmonics was to place in passive filters can be a sort of line conditioning system. The passive filter installed in a very three phase system uses the passive elements, are tuned for a particular frequency, thus provide an honest resolution thanks to their high potency, low value and simplicity.

,Power quality issues had become a problem of accelerating interest. under the situation of the deregulating of power industry and competitive market, as the main character of product, power quality can have an effect on the value of power directly in near future.

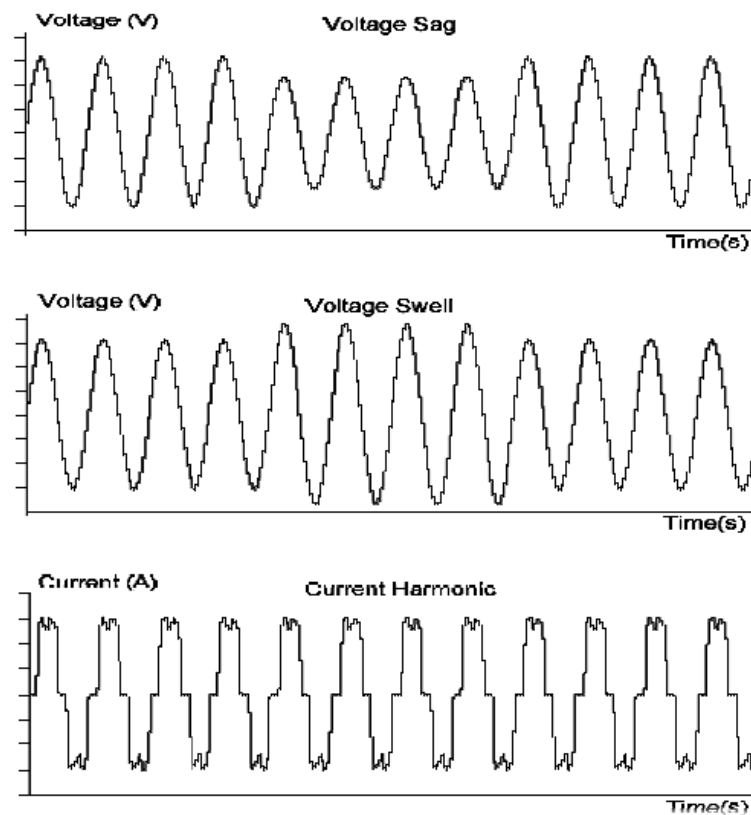

Figure 1: Most Common Types of Power Quality Issues

Figure 1 shows the most common type of Power Quality issues. The all issues are discussed in the next section.

Types of Grid Tied APFs

Generally, the active power filters are classified under two categories; DC power filters and AC power filters. The DC-APFs are installed as thyristor configurations for high-power, high-power drives and high-voltage DC system

(HVDC). Basically, the shunt APFs is classified under three categories, i.e. topology-type, converter-type and phases-type configurations.

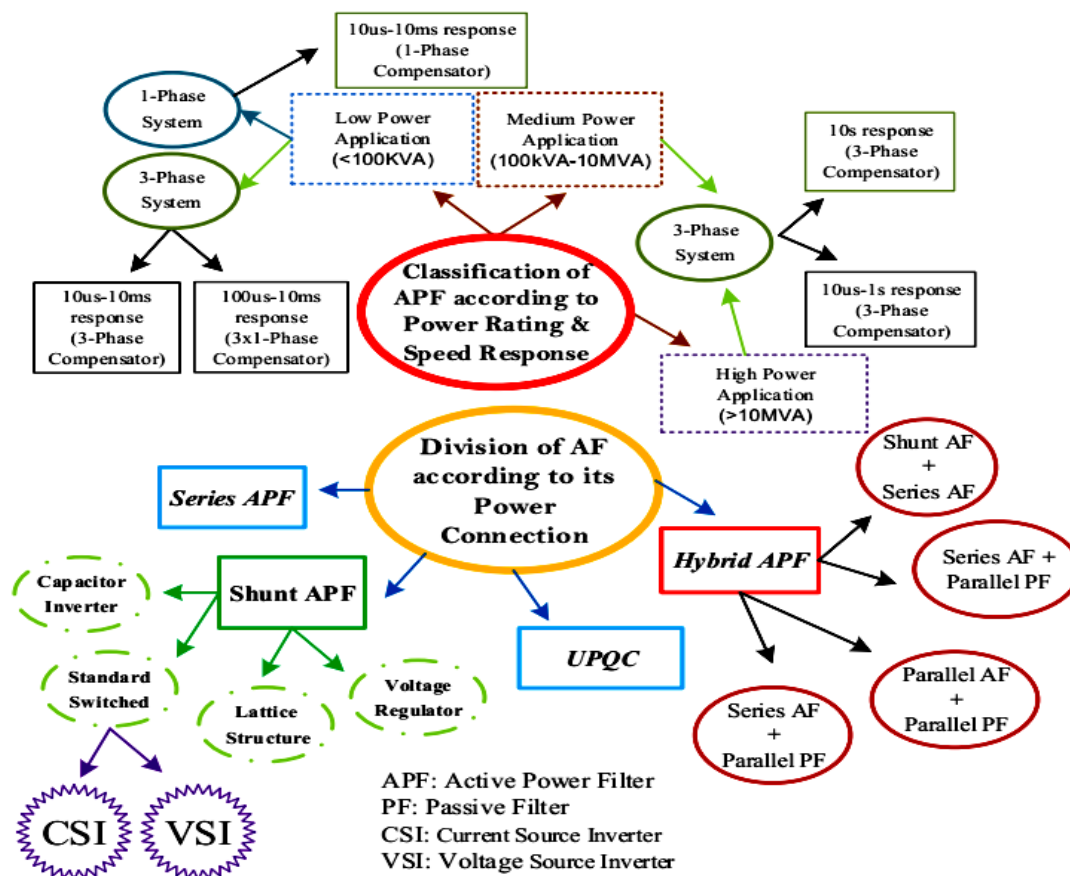

Figure 2: Classification of APFs with Hierarchical Structure

Current Source Inverter

The structure of the current source inverter is shown in Figure 4.6. It is designed with six-controllable one-way switches. It has to hold the complete current as demanded by the load. The current source active power line conditioner is connected with PCC through the series transformers that filter the carrier frequency components from the inverter currents. The dc-current offer is enforced victimization massive dc inductor in series. The inductor dc-current ought to be a minimum of as high because the peak worth of the compensating current.

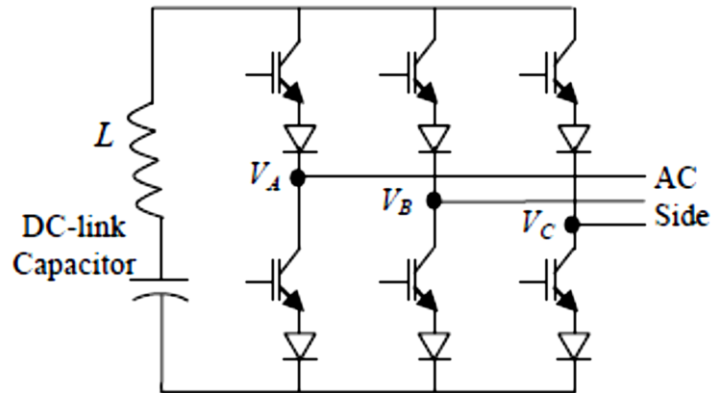

Figure 3: Current Source Inverter Topology

Principle of SAPLC

The basic principle of active power line conditioner was proposed during 1970s. However, the actual design of active power line conditioner was proposed by Gyugyi and Strycula in 1976. The shunt APLC often refers to the compensation in the current harmonics and reactive-power.

The proposed SAPLC compensates current harmonics by injecting equal-but-opposite harmonic components. It operates as current source injecting the harmonic components generated by the load but phase shifted by 180° . As a result, components of harmonic currents in the load current are cancelled by the effect of the shunt APLC and the source current remains sinusoidal and in phase with the respective voltage. This principle is applicable to any type of non-linear load that creates harmonics.

Instant PQ Theory

The idea of instantaneous active and reactive powers and its application for shunt active filter reference currents generation was created by Akagi et al. in. The instantaneous active and reactive powers for a three-phase three-wire system are described as

$$\begin{bmatrix} P \\ Q \end{bmatrix} = \begin{bmatrix} v_\alpha & v_\beta \\ -v_\beta & v_\alpha \end{bmatrix} \begin{bmatrix} i_\alpha \\ i_\beta \end{bmatrix} \quad 4.13$$

Where the three-phase voltages are modified from $a-b-c$ to $\alpha-\beta$ frame and vice-versa using the following transformation relations:

$$\begin{bmatrix} v_\alpha \\ v_\beta \end{bmatrix} = \sqrt{\frac{2}{3}} \begin{bmatrix} 1 & -\frac{1}{2} & -\frac{1}{2} \\ 0 & \frac{\sqrt{3}}{2} & -\frac{\sqrt{3}}{2} \end{bmatrix} \begin{bmatrix} v_a \\ v_b \\ v_c \end{bmatrix} \quad 4.14$$

Simulation Model

For reducing the harmonics in the power grid passive filters are popular solution but they have some problem so they can not used for optimal solution of the harmonics related issues in power grid. Shunt Active power line conditioner provide good technique for reducing the harmonics pollution as well as the compensation of the neutral current produced by the unbalanced load in the power grid.

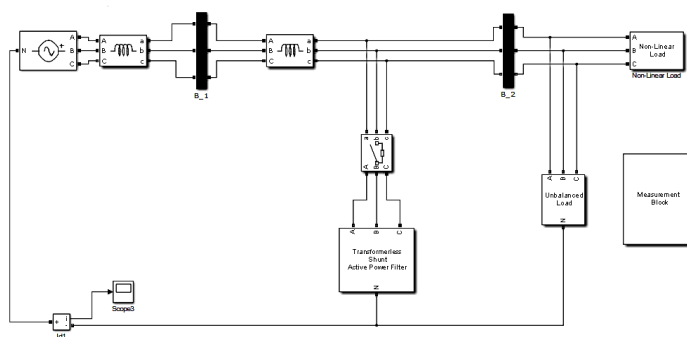

Figure 4: SIMULINK model of Proposed Shunt Active Power Line Conditioner

Result & Discussion

The whole work is simulated in MATLAB software. Table 1 shows the simulation parameter used in this work.

The whole simulation is run for 2 sec.

Table 1: SIMULINK Parameter Used in Proposed Work

System Parameter	Value
Source Voltage (V_{rms})	220 V
System frequency	50Hz

Line Parameter	$L_s=0.1 \text{ mH}$, $R_s=0.1 \Omega$
Passive inductance	$L=0.4 \text{ mH}$
Coupling Inductor	$L_f=2 \text{ mH}$
DC Side Capacitor	$11 \mu\text{F}$
k_p	0.1
K_i	1
Non-Linear Load	$L=3 \text{ mH}$, $R=30 \Omega$
Unbalanced Load	$R_a=50 \Omega$, $L=1 \text{ mH}$ $R_b=50 \Omega$, $C=1 \mu\text{F}$ $R_c=10 \Omega$

Figure 5 shows the neutral current waveform. Here the output clearly shows that without application of SAPLC the amplitude of neutral current is high. At $t=1$ when the proposed SAPLC is operated the current get suppressed.

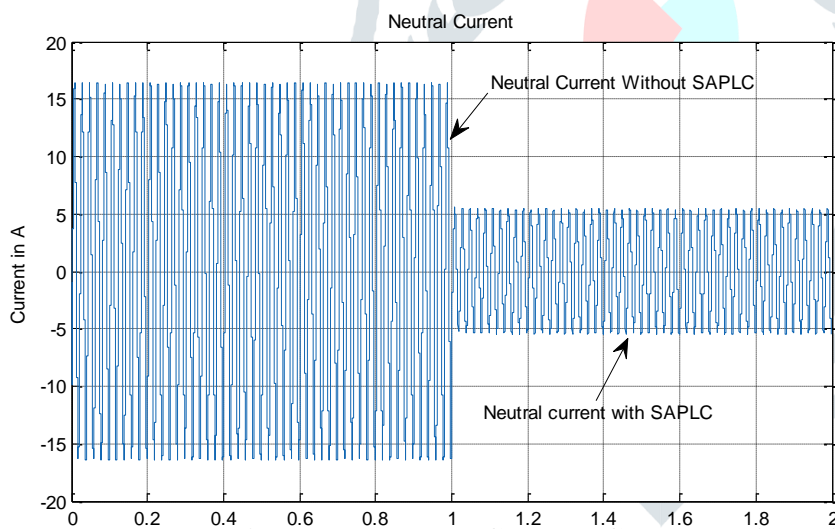

Figure 5.: Neutral Current Compensation with & without SAPLC

Figure 6 shows the grid current output waveform without proposed SAPLC.

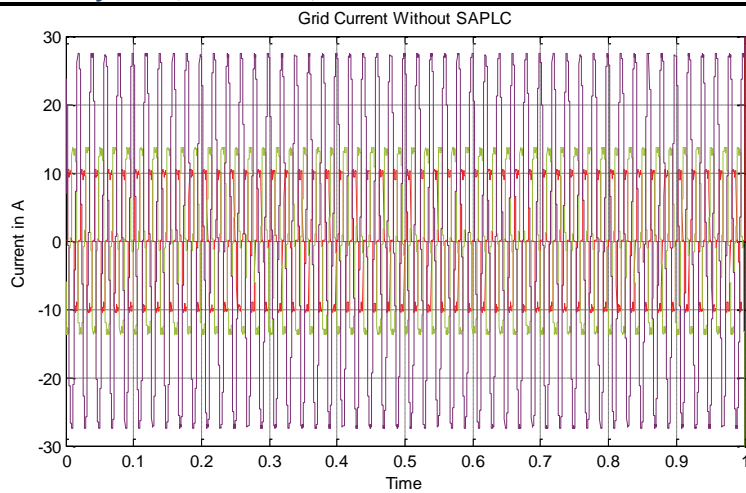

Figure 7: Grid Current without Proposed Work

Conclusion

A three phase four wire system based distribution system is always connected with different loads in the power system. Here in each pahse is connected with the identical customer with varying load. Due to regular use of non-linear load power quality issue generate in the feeder. The unbalance in the system produces neutral current in the feeder which is unsafe for the distribution system. It causes several issues in the distribution system.

Reference

- [1] Z. Zeng, H. Yang, S. Tang, and R. Zhao, "Objective-oriented power quality compensation of multifunctional grid-tied inverters and its application in microgrids," *Power Electronics, IEEE Transactions on*, vol. 30, no. 3, pp. 1255–1265, 2015.
- [2] A. B. Nassif, W. Xu, and W. Freitas, "An investigation on the selection of filter topologies for passive filter applications," *Power Delivery, IEEE Transactions on*, vol. 24, no. 3, pp. 1710–1718, 2009.
- [3] M. Ali, E. Laboure, and F. Costa, "Integrated active filter for differential-mode noise suppression," *Power Electronics, IEEE Transactions on*, vol. 29, no. 3, pp. 1053–1057, 2014.
- [4] E. R. Ribeiro and I. Barbi, "Harmonic voltage reduction using a series active filter under different load conditions," *Power Electronics, IEEE Transactions on*, vol. 21, no. 5, pp. 1394–1402, 2006

- [5] MERAL E.M., “Voltage quality enhancement with custom power park”, Ph.D. Thesis, Çukurova University, Institute of Natural and Applied Science 2009.
- [6] SANNINO A., SVENSSON J., LARSSON T., “Power electronic solutions to power quality problems”. *Electric Power Systems Research*, 66(1): pp. 71-82 2003.
- [7] CHEN S., “DSP based control of static power quality compensators in industrial power systems”, Ph.D. Electrical and Computer Engineering, Concordia University, Canada 2005.
- [8] SABIN D.D., SANNINO A., “A summary of the draft IEEE P1409 custom power application guide”, *IEEE PES Transmission and Distribution Conference and Exposition*, vol. 3, pp. 931-936 2003.
- [9] GHOSH A., LEDWICH G., “Power quality enhancement using custom power devices”, Springer, *Power Electronics and Power Systems Series*, 432 pages 2002.
- [10] Limongi, L. R., da Silva, L. R., Genu, L. G. B., Bradaschia, F., & Cavalcanti, M. C. “Transformerless Hybrid Power Filter Based on a Six-Switch Two-Leg Inverter for Improved Harmonic Compensation Performance”, *IEEE Transactions on Industrial Electronics*, 62(1), 40-51 2015.

