

DESIGN AND DEVELOPMENT OF CIRCULAR PATCH MICROSTRIP ANTENNA ARRAY FOR 24GHZ

⁽¹⁾Ms T Yathavi,
Assistant Professor, Department of ECE,
Coimbatore Institute of Technology,
Coimbatore-14.

⁽²⁾Subashini.R,⁽³⁾Subhitcha.K.N,⁽⁴⁾Subiksha.V,
⁽⁵⁾Muthu Swamy Pillai.K,
UG Scholars, Department of ECE,
Coimbatore Institute of Technology,
Coimbatore-14.

Abstract--Microstrip patch antennas are the most useful antennas for the present trend of applications especially in communication. In this paper, the proposed antenna presents the design of novel circular patch microstrip antenna array operating at 24GHz. One way of attaining antenna gain is to use an array of elements. The antenna array consists of 4 identical truncated patches that are fed through the microstrip line. The proposed antenna is a circular patch array of 2x2 elements that are etched on the material of FR-4 epoxy substrate with dielectric constant of 4.4. The operating frequency of an antenna is at 24GHz. The designed antenna has the gain of 10dB and return loss of -17dB. The proposed model is simulated using Ansoft HFSS and its return loss and radiation pattern are analyzed.

Keywords: Circular microstrip patch antenna, FR-4 substrate, HFSS, microstrip line feed.

I. INTRODUCTION

Antenna is one of the critical components in many wireless communication systems. IEEE defines an antenna as "a part of a transmitting or receiving system that is designed to radiate or receive electromagnetic waves". One of the most useful antennas is microstrip antennas. Microstrip patch antennas [2] have profound applications in the field of medical, military, mobile and satellite communication. Their utilization has become diverse because of their small size and light weight. As wireless application requires more and more bandwidth the demand for wideband antennas operating at higher frequencies become inevitable. Inherently, microstrip patch antenna has such properties. The patch may be in a variety of shapes such as rectangular, square, circular, annular ring, elliptical, triangular. But circular and rectangular are the most commonly used because of its ease of analysis and fabrication, low cross polarization. The patch is designed in such a way so that its pattern is normal to it.

II. ANTENNA DESIGN

Due to the extensive, rapid and explosive growth in wireless communication technology, there is an extensive use of low profile, low cost, light weighted antennas. All these requirements are efficiently realized by microstrip antennas. Microstrip antennas are easily integrated with microwave integrated circuits (MICs). It is also capable of dual and frequency operations. Microstrip antennas are very flexible and are used, along with other things, to synthesize a desired pattern which cannot be obtained with a single

element. So in this paper we used an array [4] to extend the performance of this antenna.

Table
.1.
Requi
red
para
meter
s

Resonant Frequency	24GHz
Substrate	FR4 Epoxy
Dielectric Constant	4.4
Radius	1.69mm
Inter-Element Spacing	6.25 to 12.5mm
Width of 100 Ω feed line	0.7mm
Width of 70.7Ω feed line	1.6mm
Width of 50 Ω feed line	3mm

he
above
Table
.1
explai
ns

about the required parameters of the proposed 2x2 circular patch microstrip antenna array design.

The radius of the circular patch can be calculated using the formulas (1), (2):

$$a = \frac{F}{\left\{1 + \frac{2h}{\pi \epsilon_r F} \left[\ln \left(\frac{\pi F}{2h} \right) + 1.7726 \right] \right\}^{1/2}} \quad (1)$$

$$F = \frac{8.791 \times 10^9}{f_r \sqrt{\epsilon_r}}; \quad (h \text{ in cm})$$

$$a_e = a \left\{ 1 + \frac{2h}{\pi a \epsilon_r} \left[\ln \left(\frac{\pi a}{2h} \right) + 1.7726 \right] \right\}^{1/2} \quad (2)$$

where,

a_e = Effective Radius of circular patch

a = Physical radius of circular patch

ϵ_r = Dielectric constant of substrate

h = Height of substrate

f_r = Frequency of operation

The calculated value of inter element spacing is in the range of 6.25mm to 12.5mm.

We also calculated the widths of each of these feedlines (3) which are dependent on their impedance values for 1x2 and 2x2 antenna arrays using the formula:

$$Z_c = \begin{cases} \frac{60}{\sqrt{\epsilon_{reff}}} \ln \left[\frac{8h}{w_0} + \frac{w_0}{4h} \right], & \frac{w_0}{h} \leq 1 \\ \frac{120\pi}{\sqrt{\epsilon_{reff}} \left[\frac{w_0}{h} + 1.393 + 0.667 \ln \left(\frac{w_0}{h} + 1.444 \right) \right]}, & \frac{w_0}{h} > 1 \end{cases}$$

The design equations for the single circular patch element are given as below:

Width of the microstrip patch antenna is given by $w =$

$$\frac{2}{c * f_0} \sqrt{\frac{2}{\epsilon_r + 1}} \quad (4)$$

Effective permittivity is calculated using $\epsilon_r = \frac{\epsilon_r + 1}{2}$

$$+ \frac{\epsilon_r - 1}{2} \left[1 + \frac{12h}{w} \right]^{-1} \quad (5)$$

Effective length is given by $L_{eff} = \frac{c}{2f_0 \sqrt{\epsilon_{eff}}}$ (6)

Length of the patch $L = L_{eff} - 2\Delta L$

Change in length, (7)

$$\Delta L = h * 0.412 \frac{(\epsilon_{eff} + 0.3) \left(\frac{w}{h} + 0.264 \right)}{(\epsilon_{eff} - 0.258) \left(\frac{w}{h} + 0.8 \right)} \quad (8)$$

Microstrip line impedance = $\frac{z_0}{2\pi \sqrt{2(1 + \epsilon_r)}} \ln \left(1 + \frac{4h}{w_{eff}} \left(\frac{14 + \frac{8}{\epsilon_r}}{11} + \sqrt{\left(\frac{14 + \frac{8}{\epsilon_r}}{11} + \frac{4h}{w_{eff}} \right)^2 + \pi^2 \frac{1 + \frac{1}{\epsilon_r}}{2}} \right) \right)$ (9)

Further, we evaluated the Return loss, Gain for single circular patch antenna, 1x2 circular patch, 2x2 circular patch microstrip antenna arrays[5] for different inter element spacing using the High Frequency Structure Simulator (HFSS) software.

III. DESIGN OF CIRCULAR MICROSTRIP PATCH ANTENNA ARRAYS

3.1 Configuration of single circular patch antenna

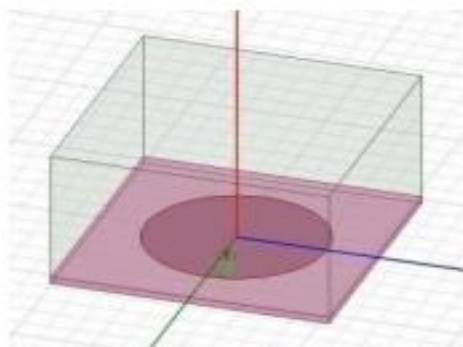

Fig.1. Configuration of single circular patch antenna

The parameters and values used for designing single circular patch antenna is given below Table.2.

Parameters	Values
a(radius of patch)	1.69 mm
Substrate	FR4 epoxy
Feed	Microstrip line feed
Inter-spacing line	6.25mm to 12.5mm
Impedance	100 Ω ,70.7 Ω ,50 Ω

Table.2. Parameters and values used for single patch antenna

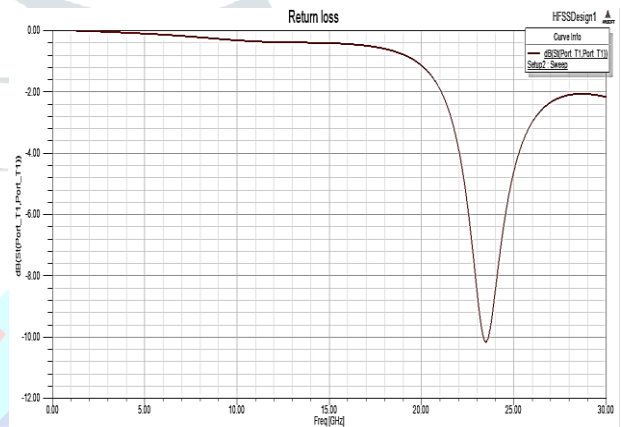

Fig.2. Plot of return loss of single circular patch antenna

Rectangular plot of the single 24GHz circular patch antenna is simulated and given in Fig.2. The plot gives return loss (S_{11} in dB) and shows desirable response. The return loss for 24GHz is obtained as -10.15dB.

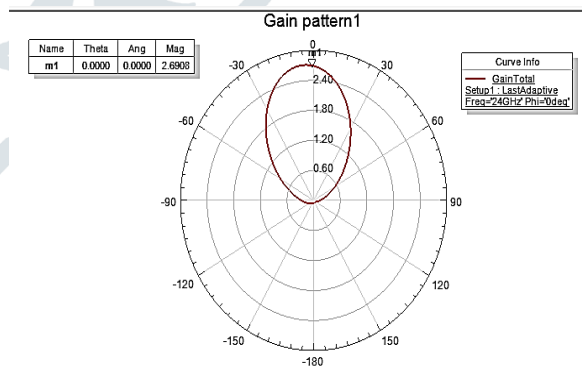

Fig.3. Gain plot of single circular patch antenna

Gain plot of the single circular patch antenna is simulated and given in Fig.3. The plot gives gain (in dB) and shows the response. The gain for 24GHz is obtained as 2.69dB.

3.2 Configuration of 1x2 circular patch microstrip antenna array

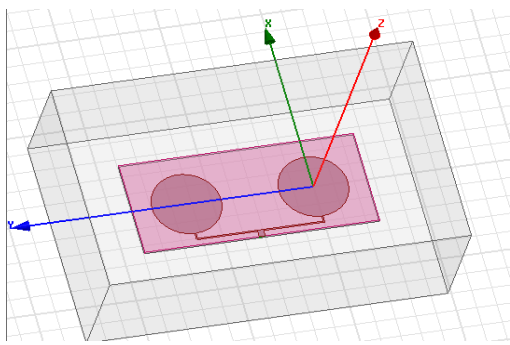

Fig.4. Geometry of 1x2 circular patch antenna array

A 1x2 circular patch antenna array [5] with 6.25λ spacing for 24GHz [8] using microstrip line feed technique has been designed as shown in Fig.4.

Parameters	Values
a (radius of patch)	1.69mm
t(thickness of patch)	0.1588mm
Feed	Coaxial feed
Material used	FR-4 Epoxy

Table.3. Parameters and values used for 1x2circular patch antenna array

The parameters and values used for designing 1x2 circular patch antenna array is shown in the above Table.3.

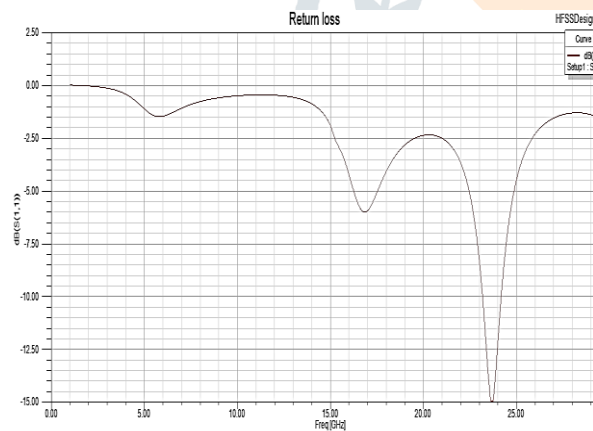

Fig.5. Plot of return loss of 1x2 circular patch antenna array with 6.25λ spacing

Rectangular plot of the 1x2 circular patch microstrip antenna array was simulated and given in Fig.5. The plot gives return loss (S_{11} in dB) and shows response. The return loss for 24GHz is obtained as -15dB.

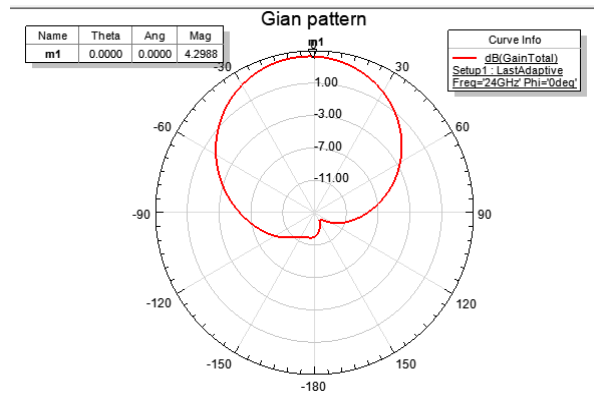

Fig.6. Gain plot of 1x2 circular patch antenna array with 6.25λ spacing

Gain plot of the 1x2 circular patch antenna array is simulated and given in Fig.6. The plot gives gain (in dB) and shows response. The gain for 24GHz is obtained as 3.2dB.

3.3 2x2 circular patch microstrip antenna array

The optimized results have been obtained by varying the distance between elements. It has been noted that there is a significant change in the return loss as the distance between the elements is changed. The return loss [10] reduces as the distance is increased up to a certain point and then again starts to increase in value. This optimal distance is found by trial and error, and by repeated simulations. Some of the simulation stages have been discussed below.

3.3.1 2x2 circular patch microstrip antenna array with 12mm spacing

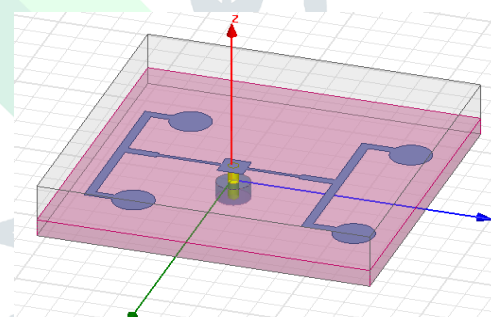

Fig.7. Geometry of the 2X2 circular patch microstrip antenna array with 12mm spacing

A 2x2 circular patch microstrip antenna array[1] with 12mm spacing for 24GHz using microstrip line feed technique has been designed as shown in Fig.7.

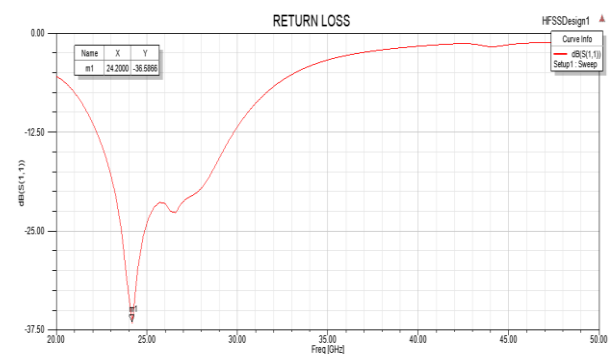

Fig.8. Plot of return loss of 2x2 circular patch microstrip antenna array with 12mm spacing

Rectangular plot of the 2x2 circular patch microstrip antenna array is simulated and given in Fig.8.

The plot gives return loss (S_{11}) in dB and shows desirable response. The return loss for 24 GHz is obtained as -37.5dB.

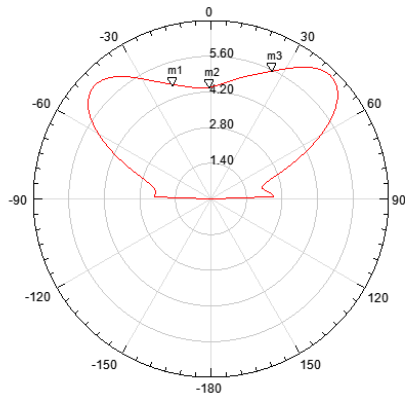

Fig.9. Gain plot of 2x2 circular patch microstrip antenna array

Gain plot of the 2x2 circular patch microstrip antenna array is simulated and given in Fig.9. The plot gives gain (in dB) and shows desirable response. The gain for 24GHz is obtained as 5.2dB.

3.3.2 2x2 circular patch microstrip antenna array with 8mm spacing

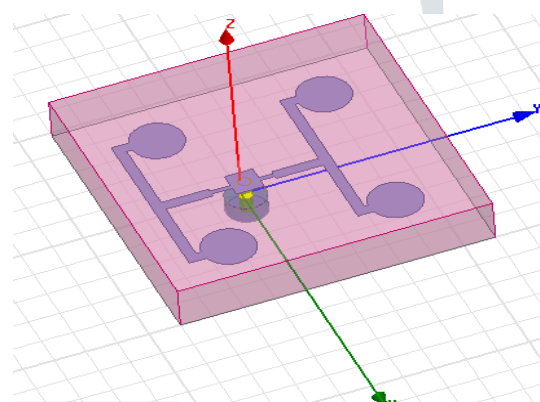

Fig.10 Geometry of the 2X2 circular patch microstrip antenna array with 8mm spacing

A 2x2 circular patch microstrip antenna array with 8mm spacing for 24GHz using microstrip line feed technique has been designed as shown in Fig.10.

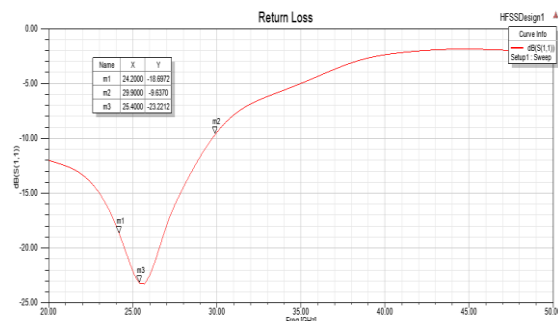

Fig.11. Plot of return loss of 2x2 circular patch microstrip antenna array with 8mm spacing

Rectangular plot of the 2x2 circular patch microstrip antenna array with 8mm spacing is simulated and given in Fig.11. The plot gives return loss (S_{11}) in dB and shows desirable response. The return loss for 24 GHz is obtained as -23dB.

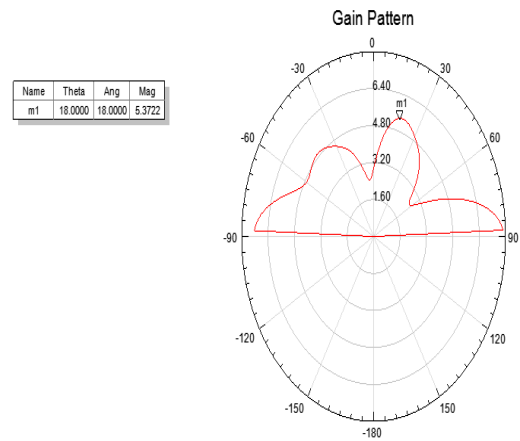

Fig.12. Gain plot of 2x2 circular patch microstrip antenna array with 8mm spacing

Gain plot of the 2x2 circular patch microstrip antenna array is simulated [11] and given in Fig.12. The plot gives gain (in dB) and shows desirable response. The gain for 24GHz is obtained as 5.3dB.

3.3.3 2x2 circular patch microstrip antenna array with 7mm spacing

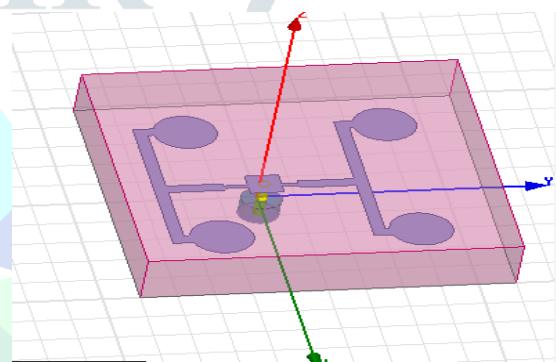

Fig.13. Geometry of the 2X2 circular patch microstrip antenna array with 7mm spacing

A 2x2 circular patch microstrip antenna array with 7mm spacing for 24GHz using microstrip line feed technique has been designed as shown in Fig.13.

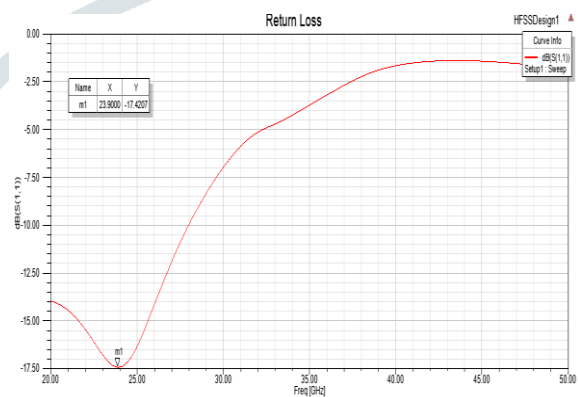

Fig.14. Plot of return loss of 2x2 circular patch microstrip antenna array with 7mm spacing

Rectangular plot of the 2x2 circular patch microstrip antenna array with 7mm spacing is simulated and given in Fig.14. The plot gives return loss (S_{11}) in dB and shows desirable response. The return loss for 24 GHz is obtained as -17dB.

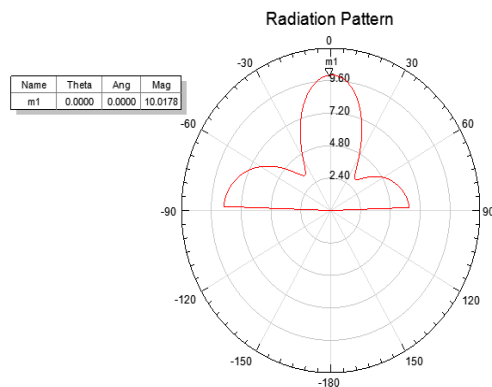

Fig.15. Gain plot of 2x2 circular patch microstrip antenna array with 7mm spacing

Gain plot of the 2x2 circular patch microstrip antenna array is simulated and given in Fig.15. The plot gives gain (in dB) and shows desirable response. The gain for 24GHz is obtained as 10dB.

3.4 Comparison of simulation result

ANTENNA	RETURN LOSS (dB)	GAIN (dB)
Single circular patch microstrip antenna	-10.15	2.69
1x2 circular patch antenna array	-15	4.2
2x2 circular patch microstrip antenna array (12mm spacing)	-37.5	5.2
2x2 circular patch microstrip antenna array (8mm spacing)	-23	5.3
2x2 circular patch microstrip antenna array (7mm spacing)	-17	10

Table.4. Comparison of the various antenna models

The Table.4 shows the comparison of the various antenna models simulated. We can see that for the single circular microstrip patch antenna although the return loss is considerably low, the gain is less. Therefore to improve the gain and the directional capabilities of the antenna, a linear array antenna has been designed. The gain significantly improves on using two elements connected by a corporate stripline feed[7]. However the return loss also increases. Therefore to optimise the return loss, the distance between the elements has been varied. On increasing the distance between the patches, the return loss was found to decrease considerably upto a certain point. On further increasing the distance, the return loss was found to increase. Hence a distance of 7mm spacing was fixed.

IV. CONCLUSION

Microstrip patch antenna arrays of circular shaped radiating elements were successfully designed and implemented using the FR-4 epoxy[9] glass substrate. Through the analysis of HFSS simulation software, it was observed that the antenna resonated at 24 GHz frequency. In this work, microstrip feedline technique was used for the simulation of 2x2 circular patch antenna array. From the

proposed simulation design, the maximum achieved gain was 10dB and return loss was -17 dB. Microstrip antennas have narrow bandwidth and low efficiency and their performance greatly depends on the substrate parameters. Advantage of circular patch over the rectangular patch is the need of lesser area. But they have high input impedance along the circumference as a disadvantage. Although antennas may be considered old technology, researchers are finding ways to innovate the antenna for the next generation of electronics.

ACKNOWLEDGMENT

During the course of writing this paper, we have received help, encouragement and assistance from our guide Ms.T.Yathavi, Assistant Professor, Coimbatore Institute of Technology. We are deeply indebted to our guide for her valuable guidance which has been highly useful in writing this paper.

REFERENCES

- [1] Qurratul Ayn, Dr. P.A. Nageswar Rao, Prof. P. Mallikarjuna Rao "Design and Analysis of High Gain 2x1 and 4x1 Circular Patch Antenna Arrays for 2.4 GHz Applications", International Journal of Innovative Research in Science (IJIRS), Engineering and Technology, Volume. 6, Issue 8, August 2017.
- [2] Nusrat Jahan Shimu; Anis Ahmed, "Design and performance analysis of Rectangular Microstrip Patch Antenna at 2.45GHz", Institute of Electrical and Electronics Engineers (IEEE) conference on Informatics, Electronics and Vision, pp.1062-1066 ,2016.
- [3] Dheeraj Mungur and Shankar Duraikannan in "Design and Analysis of 28GHz Millimeter Wave Antenna Array for 5G Communication Systems", Institute of Electrical and Electronics Engineers Conference Publication, Volume.1, Issue 3, August 2018.
- [4] I.Radnovic,B.Jokanovic, A.Borvsenko, "Circularly Polarized Patch Antenna Array at 24 GHz for Radar Applications", Institute of Electrical and Electronics Engineers(IEEE) conference publication, xplorer,Volume.6,IssueNo.3, pp.1133-1139,November 2018.
- [5] Shanthi.P, Yashvi Mehlshah, "Design and Analysis of 1x2 circular patch antenna array for 2.4GHz applications", International Journal of Recent Technology and Engineering, Volume.8, Issue.4, November 2019.
- [6] Md.Hossain;Md.Rana;Md.Anower;Alok Paul, "Enhancing the performance of rectangular patch antenna using E shaped slot technique for 5.75 GHz ISM band applications", Institute of Electrical and Electronics Engineers conference on Informatics, Electronics and Vision, pp.449-453,2016.
- [7] Nikita Sharma, Bhawana Jain, Pradeep Singla, Raj Ranjan Prasad, "Rectangular Patch Micro Strip Antenna", International Advanced Research Journal in Science, Engineering and Technology Volume.1, Issue 3, November 2016.
- [8] Houda Werfelli, Khaoula Tayari, "Design of Rectangular Microstrip Patch Antenna" 2nd International Conference on Advanced Technologies, March 21-24, 2016.

- [9] M.Shen,G.F.pederson et.al, “A 28 GHz FR-4 compatible phased array antenna for 5G mobile application”,Institute of Electrical and Electronics Engineers ,2015.
- [10] Farizah Ansarudin, Tharek Abd Rahman et.al, “Design of Dielectric Lens Antenna for 5G Mobile Base Station”, Institute of Electrical and Electronics Engineers, October 2018.
- [11] Umair Rafique,Hisham Khalil et.al, “Microstrip Patch Antenna Array For 5G Mobile Communications”, Progress In Electromagnetics Research, November 2017.

Author Profile:



Ms.T.Yathavi received her Bachelor's degree in Electronics and Communication Engineering from Government College of Engineering, Salem, Tamil Nadu, India and later she received her Master's degree from Coimbatore Institute of Technology, India. She is currently working as an Assistant Professor in the Department of Electronics and Communication. Specialized in the field of re-configurable antenna.



Subashini.R, UG Scholar, Department of Electronics and Communication Engineering, Coimbatore Institute of Technology, Coimbatore.



Subhitcha.K.N, UG Scholar, Department of Electronics and Communication Engineering, Coimbatore Institute of Technology, Coimbatore.



Subiksha.V, UG Scholar, Department of Electronics and Communication Engineering, Coimbatore Institute of Technology, Coimbatore.



Muthu Swamy Pillai.K, UG Scholar, Department of Electronics and Communication Engineering, Coimbatore Institute of Technology, Coimbatore.