

SIGNIFICANCE OF IOT-SMART CARD IN HEALTH CARE SECTOR FOR CRITICAL PATIENT CARE

¹Shamita Shivashankar Hiremath, ² Dr. Yogesh Kumar Sharma

¹Research Scholar JJT University, Jhunjhunu, ²Associate Professor

¹Department of Electronic and communication Engineering,

¹JJTU Jhunjhun, India.

Abstract : Critical care assists persons by deadly accidental injuries as well as , ailments. It may deal with challenges such as problems via medical procedures, incidents, attacks, and serious deep breathing concerns. It entails close, continuous interest through a group among uniquely trained well-being care companies. Critical care generally requires place in ICU as well as trauma middle. Screens, intravenous pontoons, nourishing hoses, catheters, inhaling and exhaling devices, as well as, additional equipment will be prevalent in critical care models. They may maintain a person in, however, can likewise boost the risk of contamination. Critical care solutions fulfill the requirements of individuals bracing for an instant life-threatening overall health condition particularly, that in which essential system organs will be at concerns of faltering. Applying high level restorative, monitoring and analysis concept, the goal among critical care is usually to preserve body organ program working as well as , enhance the patient's state many of these that his or perhaps his fundamental damage or disease can after that become cured. Therefore, this paper reveals the part concerning smart cards in critical care/health care.

IndexTerms - Smart card, IoT, Critical Care, Healthcare IoT.

I. INTRODUCTION

Vitally sick sufferers present a totally diverse collection of difficulties for both the doctors mainly because very well as the types who will be in demand of acquiring care concerning them [1]. Many of these people need continuous monitoring, care and assist to become capable to obtain back again to overall health. In these a scenario, the part of critical care medical turns into very important to the patient's wellbeing. In the event that the patient is usually accepted in an ICU, there is definitely an whole group of specific doctors, healthcare professionals, dietician, physiotherapist as well as , additional skilled staff present to appear after every want [2].

Best by keeping an vision on the patient's bloodstream pressure, to calculating their heat each and every 2-3 time and via giving medications to recoding their center price; everything is usually handled by the breastfeeding personnel within the ICU to ensure there can be no drop in the patient's health and wellbeing as well as if they discover a specific thing dubious, record it instantly to the worried doctor [3].

The part of critical care breastfeeding staff consequently turns into of greatest importance when it gets into assisting an individual recoup. However, will which usually powerful switch in the event that the comparable treatment is usually getting given to an individual by a medical personnel affiliate during the limits among the patient's house? Oftentimes occasions, vitally ill patients will be delivered residence on the demand of the family members in order that these may easily end up being used care of by them [4]. In such a situation, the family members choose to consider help of a professional home care health professional so that it may evaluate the patient's well being, look after them 24×7 and if want get co-ordinate with the doctor on the improvement staying produced through individual. Yes, house overall health care environment is usually completely diverse via that one may discover in a medical center, however , with professional support at removal can in fact restore and experience better. Within the critical care of a professional, clients can find out to live with higher self-reliance, include gain access to their adored types any period of the day time even though attaining ideal level of wellbeing [5].

Critical care nursing is usually a niche concentrated just on the care of unpredictable, persistently sick or post-surgical patients as well as, those who will be at concerns of life-threatening conditions and accidental injuries. Like additional medical specialties, critical care healthcare professionals own an awareness of human being body structure as well as physiology, they contain razor-sharp medical evaluation abilities, and huge understanding about disorders and circumstances, as well as education related to suggested ICU treatment choices [6]. Vitally unwell individuals frequently need regular monitoring and assistance for faltering body organs. The critical care nurses will be the experts in cardiopulmonary resuscitation methods. They may make use of life-saving gear many of these as cardio-verters, defibrillators and mechanized air flow. They care for a wide selection among sufferers incorporating medical, surgical, neonatal, pediatric, neurology, cardiac, pulmonary, transplant, as well as , trauma/burn off to brand

II Critical Patient Care

Patients struggling from life-threatening illnesses possess a large risk for an unexpected scientific damage. Study on cardiac busts displays which usually signs of deterioration will be noticeable in patient's vital indicators many time just before event. Consequently, conjecture of impending specialized medical deterioration is usually feasible by spending plenty of interest to individual position. Constant individual monitoring in many of these a scenario provide on early recognition as well as , quick response in a type of early on treatment and avoidance of perilous instances. It can as well lower the tension on medical center assets, decrease the connected costs as well as virtually all significantly, decrease fatality [15].

All well being records and measurements had been kept into a pc machine and an info foundation that may become utilized through the doctors/nursing staff simply by a consumer friendly user interface. The web-based overall health monitoring software will evaluate as well as , course of action the info from all the products via ICU and shows in actual period the doctors about the swapping of essential variable or the motion of the patients as well as , also relating to the essential reforming in external guidelines, in purchase to consider precautionary steps [16].

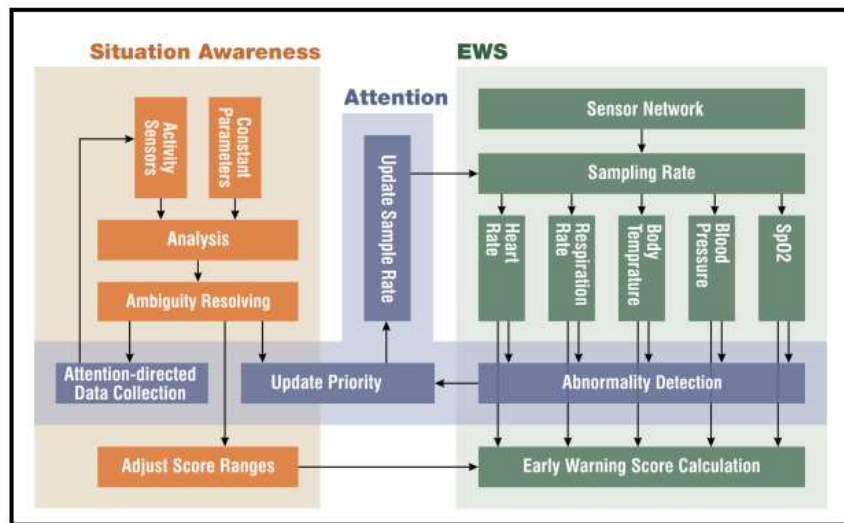

Figure 1: Self care sensor network system (Azimi et al.)

Figure 1 over displays an existing IoT program. Continuous system features within the the monitoring not really just can result in strength inefficiency and improved decision producing latency, but likewise help to make the program vulnerable in circumstance of crisis due to certainly not spending ample interest to critical guidelines. Mobile program offers a vital component of the consumer user interface of the medical sensor device as well as in addition data indication route via the server at doctor's center.

Supervision request gives info a professional to break down and evaluate patient's disease as well as in addition providing data individual to light up his health state. In any case, all medical data is usually place aside in his personal mobile phone and doctor's facility info machine suggested by the customer, yet not cloud storage space. Many customers may choose not really to shop their medical info in the cloud hardware in light of protection, mainly because made an appearance as the failed circumstance, Google Health Support.

Center charge data can end up being actually beneficial regardless of your developing an workout program, learning the processes or perhaps stress amounts or simply need your t-shirt to blink with the heart defeat. The problem is usually that center amount can get hard to assess. Fortunately, the Heart beat Sensor Amped may resolve that issue. The Beat Sensor Amped is usually a plug-and-play heartrate sensor for Arduino. It can be utilized to very easily include friendly heart-rate info straight to the tasks .It actually blend a basic optic heart and soul fee sensor with hyperbole as well as , sound cancellation circuitry which makes it quickly and simple to obtain dependable heartbeat psychic readings.

III SMART IOT DEVICES

Internet of Things (IoT) products can become mainly utilized to help additional wellness monitoring as well as crisis health care systems. The Internet and World-Wide Web (www) has were a main driver of syndication as well as , provides advertised the concurrence of digital marketing communications and press solutions. The net features right now turn into a moderate of interpersonal conversation. It can be a vital advancement that may modify as well as , effect the method persons work, live and learn.

Internet of issues, as a network of linked corporal and digital factors, is certainly propagating in every part of the globe as well as , top rated us to smart alternatives by building a fresh informative moderate. It allows the stuff with exclusive details to fulfill prevalent goals even more effective by communicating with each additional. Taking into consideration a cellular body sensor network for studying patients essential indicators and an smart cloud support for digesting the patient's medical info, making use of the Internet of Things is normally relevant for constant individual monitoring to resolve the disadvantages of recent hands-on Early on Caution Rating devices together pertaining to removing the mistakes in documenting as well as , increasing the answer to out of medical center.

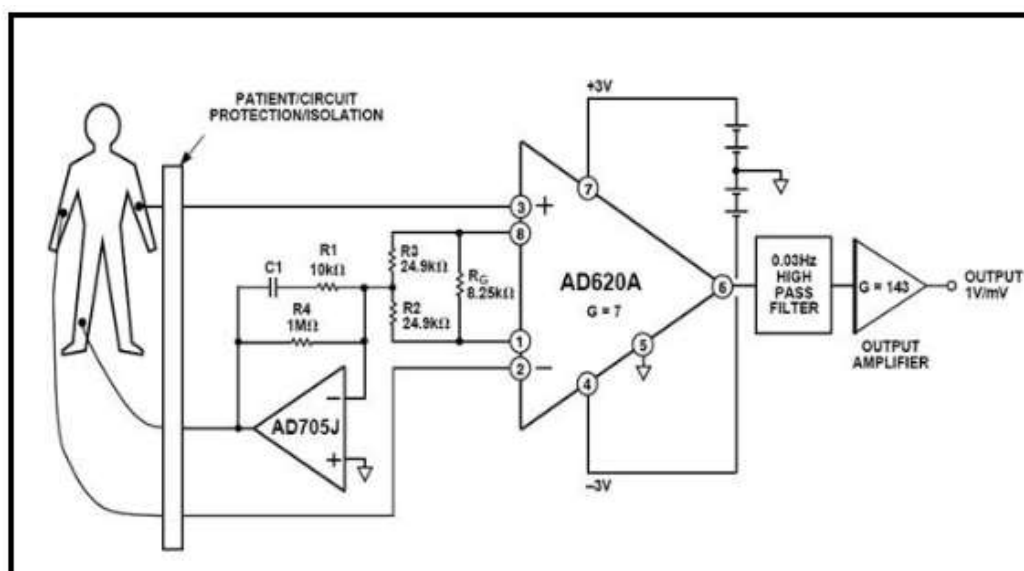

Figure 2: Component circuit for smart card synchronization

As shown in figure 2 above, the detection and analog to digital conversion of signals can be fed to smart card recorded. When actual values exceed the normal setting values the alarm setting can alert to the patient.

In the recent years, the Internet features turn into the main point in people's existence. In the Internet of Things (IoT) paradigm, several of the items that encompass us will get on the network in one type or one other. The latest developments in cellular realizing concept have got contributed to the introduction of a wide collection of applications in various domain names such as medical, sports activities, customer electronics, interpersonal networking, and business utilization. E-Health acknowledged as the most important and encouraging for such uses credited to its potential for health monitoring of persistent ailments, life saving in disaster circumstances, as well as its capability to offer round the time clock health care to outlying and deprived areas.

As one of the effects of many of these mechanized blending, the healing array possesses benefitted from new innovations in sensors format as well as remote communication advances. In particular, the continuous miniaturization of electrical products has got strengthened the advancement of e-health monitoring. These include diverse types of beneficial and non-medicinal sensors placed in cell telephones, wearable devices in, close by the patient's body, filling up in as critical parts of remote control body area devices, or WBAN in brief. Past due years include noticed a speedy improvement of cell devices sensors, body sensors, and distant correspondences, that help to make a route for effective well-being observing. The individual solutions errands will be appropriately relocated via classic medical environment to pervasive simple to make use of conditions. Similarly, the range of seeing topics could come to be essentially prolonged, moving by the patients at critical care, at e.g., in an emergency automobile, to those with constant illnesses.

Particularly, the body sensors communicated in, near to the individuals body, as well as the environment mindful sensors like the types injected in cell phones, can be used to evaluate the fundamental well being guidelines or important indicators, pertaining to case in point, heartbeat, temperature, circulatory stress. The electrocardiogram (ECG or EKG) is definitely the store of heart's electrical processes. These muscles will be electrically billed at snooze as well as , obtain caught through depolarizing the demand. ECG can be the chart of these electrical signals. It provides the details about heart price and rhythm, as well as , the mass or quantity of the areas of heart.

IV CONCLUSION

The body sensor network (BSN) concept with smart cards control is definitely one of the virtually all essential systems utilized in IoT-based contemporary health care system. It can be essentially a group of low-power as well as light-weight cellular sensor nodes that are being used to keep an eye on the human being body features and encircling environment. As BSN nodes are being used to gather delicate info as well as may run in aggressive conditions, appropriately, they need rigid protection systems to stop harmful conversation by the program.

REFERENCES

- [1] Rathee, Geetanjali, et al. "A hybrid framework for multimedia data processing in IoT-healthcare using blockchain technology." *Multimedia Tools and Applications* (2019): 1-23.
- [2] Jia, Xiaoying, et al. "Authenticated key agreement scheme for fog-driven IoT healthcare system." *Wireless Networks* 25.8 (2019): 4737-4750.
- [3] Tekeste, Temesghen, et al. "Ultra-low power QRS detection and ECG compression architecture for IoT healthcare devices." *IEEE Transactions on Circuits and Systems I: Regular Papers* 66.2 (2018): 669-679.
- [4] Reda, Roberto, Filippo Piccinini, and Antonella Carbonaro. "Towards consistent data representation in the IoT healthcare landscape." *Proceedings of the 2018 International Conference on Digital Health*. 2018.

- [5] Kim, Suwon, and Seongcheol Kim. "User preference for an IoT healthcare application for lifestyle disease management." *Telecommunications Policy* 42.4 (2018): 304-314.
- [6] Onasanya, Adeniyi, and Maher Elshakankiri. "Smart integrated IoT healthcare system for cancer care." *Wireless Networks* (2019): 1-16.
- [7] Jebadurai, Jebaveerasingh, and J. Dinesh Peter. "Super-resolution of retinal images using multi-kernel SVR for IoT healthcare applications." *Future Generation Computer Systems* 83 (2018): 338-346.
- [8] Bulaghi, Zohre Arabi, et al. "SENET: A novel architecture for IoT-based body sensor networks." *Informatics in Medicine Unlocked* (2020): 100365.
- [9] Muzammal, Muhammad, et al. "A multi-sensor data fusion enabled ensemble approach for medical data from body sensor networks." *Information Fusion* 53 (2020): 155-164.
- [10] Zhao, Jiayi, and Guangxue Li. "Study on real-time wearable sport health device based on body sensor networks." *Computer Communications* 154 (2020): 40-47.
- [11] Chander, Bhanu. "Wireless Body Sensor Networks for Patient Health Monitoring: Security, Challenges, Applications Security, Challenges, Applications–IoT Healthcare Management." *Smart Medical Data Sensing and IoT Systems Design in Healthcare*. IGI Global, 2020. 132-154.
- [12] Liu, Xiao, et al. "Adjusting forwarder nodes and duty cycle using packet aggregation routing for body sensor networks." *Information Fusion* 53 (2020): 183-195.
- [13] Sodhro, Ali Hassan, et al. "Power-management strategies for medical information transmission in wireless body sensor networks." *IEEE Consumer Electronics Magazine* 9.2 (2020): 47-51.
- [14] Pandey, Atul Kumar, and Nisha Gupta. "An energy efficient distributed queuing random access (EE-DQRA) MAC protocol for wireless body sensor networks." *Wireless Networks* (2020): 1-15.
- [15] Jiang, Xiangyuan, et al. "Dynamical Attitude Configuration with Wearable Wireless Body Sensor Networks through Beetle Antennae Search Strategy." *Measurement* (2020): 108128.
- [16] Qiu, Han, Meikang Qiu, and Zhihui Lu. "Selective encryption on ecg data in body sensor network based on supervised machine learning." *Information Fusion* 55 (2020): 59-67.

