

# MODELING AND SIMULATION OF 4 LEG 3 PHASE INVERTER FOR HIGH POWER QUALITY BY USING BESS IN MICRO GRIDS

TANGUTURI. SOWJANYA<sup>1</sup>, S. KRANTHI KUMAR<sup>2</sup> SK. MEERA SHAREEF<sup>3</sup>

<sup>1</sup> PURSUING M-TECH IN IN PRAKASAM ENGINEERING COLLEGE. KANDUKUR.

<sup>2,3</sup> ASSISTANT PROFESSORS IN EEE DEPARTMENT IN PRAKASAM ENGINEERING COLLEGE. KANDUKUR.

## ABSTRACT:

Increasing need for dispersed generation based upon Renewable Energy Sources (RES) has actually caused numerous concerns in the procedure of energy grids. The micro grid is an encouraging option to address these troubles. A specialized power storage space system might add to a much better assimilation of RES right into the micro grid by smoothing the renewable energy's intermittency, boosting the high quality of the infused power as well as making it possible for extra solutions like voltage and also regularity policy. Nevertheless, as a result of energy/power technical restrictions, it is frequently needed to utilize Hybrid Energy Storage Systems (HESS). In this paper, a 2nd order moving setting controller is recommended for the power circulation control of a HESS, making use of a Four Leg Three Level Neutral Point Clamped (4-Leg 3LNPC) inverter as the only user interface in between the RES/HESS and also the micro grid. A three-dimensional area vector inflection as well as a series decay based Air Conditioner side control permits the inverter to operate in out of balance tons problems while preserving a well balanced Air Conditioning voltage at the factor of usual combining. DC existing harmonics triggered by out of balance lots as well as the NPC drifting center factor voltage, along with the power department restrictions are thoroughly dealt with in this paper. The efficiency of the recommended strategy for the HESS power circulation control is as compared to a timeless PI control system and also is verified with simulations as well as experimentally utilizing a 4 Leg 3LNPC model on an examination bench.

**Keywords:** *4leg 3 phase inverter, PI controller, NPC inverter.*

## 1. INTRODUCTION:

The boosting infiltration of DG is altering administration of the grid from streamlined to decentralized plans, producing numerous difficulties that have to be very carefully dealt with in order to maintain the electric grid's correct procedure. High infiltration of renewable resource could bring about security and also power high quality concerns because of the stochastic nature of RES, such as wind and also solar power. The mini grid idea, which could be specified as a tiny range weak electric grid that has the ability to run both in linked and also is-landed setting, has actually been thoroughly examined as a remedy for RES assimilation. The weak nature of mini grid indicates making use of an Energy Storage System (ESS) to boost RES infiltration and also guarantee its security. Making use of an ESS incorporates restraints such as acceptable data transfer, optimum rankings, current/power optimum slope and also

the variety of cycles. If these restraints are not appreciated it could cause a significant life time decrease of the ESS, in particular instances, to its devastation. Making use of a Hybrid Energy Storage System (HESS) provides the required compromise for boosting the life time of each ESS while likewise raising the worldwide details power and also power of the entire system. Lastly, regardless of a reduced adaptability when compared with the identical geography, the 3L-NPC geography d) could be made use of as a solitary power converter able to handle the power circulation of a HESS, working as a user interface in between the RES and also the grid. Because of the decreased voltage used on the buttons as well as a raised variety of voltage degrees, the 3L-NPC geography ends up being a lot more reliable while revealing a reduced existing Total Harmonic Distortion (THD) compared to a comparable 2 degree inverter. A number of jobs have actually been performed on ESS hybridization making use of multilevel geographies,

consisting of the 3 Leg 3L-NPC. The 4-Leg 3L-NPC made use of as an energetic power filter is additionally thoroughly examined in the literary works. Many thanks to the 4th leg this inverter has the ability to generate absolutely no series currents along with guide and also unfavorable ones.

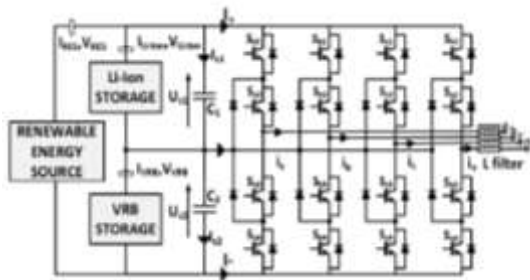

Fig.1.1. Proposed model.

## 2. PREVIOUS STUDY:

This particular allows settlement for the boosting variety of out of balance lots (monophonic consumers, electrical automobiles ...) and also solitary stage generators (tiny wind/PV systems). In [a number of inflection methods as well as repetitive vector option techniques are made use of to stabilize the capacitor voltages in power filter application. In, the Air Conditioner side anticipating control of a 4 Leg 3LNPC inverter in separated setting enhances the efficiency as well as the power high quality. In a non-linear control technique is established for a 4 Leg 3L-NPC inverter made use of as an energetic power filter. Nevertheless, the 4- Leg 3L-NPC inverter utilized both as a power filter as well as a HESS user interface for a RES assimilation right into the grid is not resolved in the literary works. The application of associate level ESS incorporates restrictions like admittable info procedure, a lot of scores, current/power most slope as well as for that reason the range of cycles. If these restrictions do not appear to be admired it will certainly lead to a significant period decrease of the ESS, or in certain instances, to its damage. The usage of a Hybrid Energy rearrange or Storage or rearrange Scheme (HESS) uses the called for compromise for enhancing the moment duration of ESS where as furthermore boosting the globe details power and also power of the whole system. Fig. 1 reveals the primary frameworks currently located within the literary works to incorporate a HESS right into a grid. The easy geography a) reveals a deficiency of monitoring of the

capacity circulation in addition due to the fact that the ESSs State of Charge (SOC). The drifting b) as well as identical c) geographies are square procedure energetic geographies that make use of DC/DC converters to take care of power moves straight. Ultimately, in spite of a reduced adaptability compared with the identical geography, the 3L-NPC geography d) will certainly be made use of as one power convertor prepared to take care of the capability circulation of a HESS, working as associate level user interface in between the RES as well as for that reason the grid. As an outcome of the decreased voltage used on the buttons link degreed an increased selection of voltage degrees, the 3L-NPC geography ends up being a great deal of affordable whereas revealing a reduced existing Total Harmonic Distortion (THD) It " s revealed that, beyond the borders of the 3L-NPC geography, the strength and also doctorate renovation develop this geography suitable for ESS sex-related union.

## 3. PROPOSED SYSTEM:

The reduction, or outright elimination, of energy storage requirements, simplifies the device and eliminates the one component that is expected to define its lifetime. Instead of a decade, a three-phase microinverter could be built to last for the lifetime of the panel. Such a device would also be less expensive and less complex, although at the cost of requiring each inverter to connect to all three lines, which possibly leads to more wiring. The boosting infiltration of DG is altering monitoring of the grid from streamlined to decentralized plans, developing a number of obstacles that need to be very carefully resolved in order to maintain the electric grid's appropriate procedure. High infiltration of renewable resource could bring about security as well as power top quality problems as a result of the stochastic nature of RES, such as wind and also solar power. The microgrid idea, which could be specified as a little range weak electric grid that has the ability to run both in linked as well as islanded setting, has actually been thoroughly researched as a service for RES combination. The weak nature of a micro grid suggests using an Energy Storage System (ESS) to enhance RES infiltration as well as guarantee its security [1]-- [3] Making use of an ESS incorporates restrictions such as acceptable data transfer,

optimum rankings, current/power optimum slope and also the variety of cycles. If these restraints are not appreciated it could bring about a remarkable life time decrease of the ESS, or in specific instances, to its damage. [4], [5] Using a Hybrid Energy Storage System (HESS) provides the essential compromise for enhancing the life time of each ESS while likewise enhancing the international particular power and also power of the entire system.

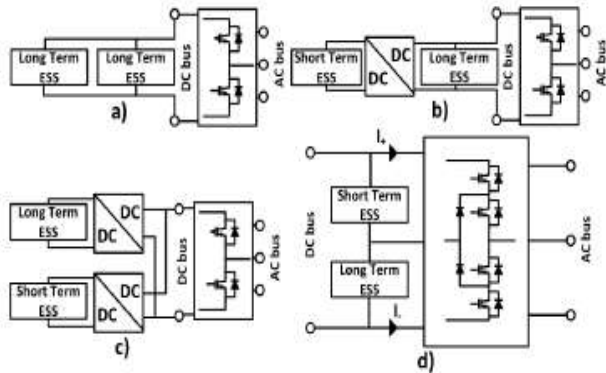
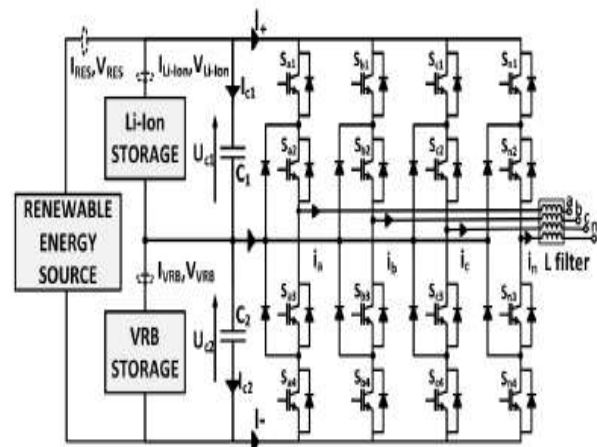

**Fig.3.1. Power converter topologies for microgrid ESS hybridization**  
**(a) Passive (b) floating (c) parallel (d) 3L-NPC topology.**

Numerous jobs have actually been accomplished on ESS hybridization making use of multilevel geographies, consisting of the 3 Leg 3L-NPC. In [13], a PI controller is created to manage the power circulation of a Vanadium Redox Flow Battery (VRB) whereas a Super Capacitor (SC) offers the quick variant of power with both parallel as well as 3 Leg 3L-NPC inverters. It is revealed that, past the restrictions of the 3L-NPC geography, the effectiveness and also THD renovation make this geography appropriate for ESS hybridization. One more particularity of this geography is the drifting DC web link center factor voltage which entails voltage surges at 3 time the basic regularity (i.e. 150 Hz) [16]-- [20] The harmonic sizes are straight connected to the inflection strategy utilized, in addition to the DC web link filter features These voltage surges paired to very out of balance A/C lots might trigger big DC existing harmonics which could raise electro-magnetic disturbance (EMI) as well as influence ESSs life time because of enhanced thermal losses This result might be intensified by an abject DC web link filter.

The 4-Leg 3L-NPC utilized as an energetic power filter is likewise thoroughly researched in the literary works

[19] Many thanks to the 4th leg this inverter has the ability to create no series currents along with route as well as adverse ones. This particular allows payment for the enhancing variety of out of balance lots (monophonic consumers, electrical lorries ...) as well as solitary stage generators (tiny wind/PV systems). In [19], [27], [29] a number of inflection strategies as well as repetitive vector choice techniques are utilized to stabilize the capacitor voltages in power filter application. In [27], the A/C side anticipating control of a 4 Leg 3L-NPC inverter in separated setting boosts the efficiency and also the power high quality. In [30] a non-linear control technique is established for a 4 Leg 3L-NPC inverter utilized as an energetic power filter. Nevertheless, the 4-Leg 3L-NPC inverter made use of both as a power filter as well as a HESS user interface for a RES assimilation right into the grid is not resolved in the literary works.



**Fig.3.2. 4-Leg 3L-NPC topology used as a HESS/RES interface.**

The checked out HESS is created of a Li-Ion battery and also a VRB. The VRB modern technology gain from the decoupled details power (which relies on the pile attributes) as well as its particular power (which depends upon quantity of electrolyte storage tanks). Together with the adaptability provided by this uniqueness, the innovation is likewise fit to long-term power storage space as there is almost no self-discharge with an excellent big salami effectiveness of 78%-88% [34] The Li-Ion battery gain from a high particular power as well as modest self-discharge (1-5% each day). This innovation has actually additionally been established for high power standalone applications in recent times [35] As a result, using these 2 innovations is

corresponding and also understands a high particular power as well as high certain power HESS.

#### 4. SIMULATION RESULTS:

The power circulation monitoring of a HESS made up of a Li-Ion battery as well as a Vanadium Redox Battery (VRB) is checked out in a micro grid context. The 4 Leg 3LNPC inverter has actually been opted to user interface the HESS with the microgrid because of its reduced THD, high effectiveness and also its capability to handle out of balance Air Conditioner tons with the 4th leg. The goal of the paper is to verify that by including the 4th leg to a 3L-NPC converter as well as making use of a brand-new DC side control approach it is feasible to get to both rapid as well as reliable DC power sharing in between both ESSs as well as the RES, and also at the exact same time boosts the A/C side power high quality. The major payment of this paper stocks the DC power circulation controller which enables HESS power circulation control as well as DC existing harmonics reductions. The brand-new design for 4-Leg 3L-NPC architectural restrictions suggested in is assessed. The performance of the suggested system has actually been checked with simulations and also speculative examinations utilizing a research laboratory model.

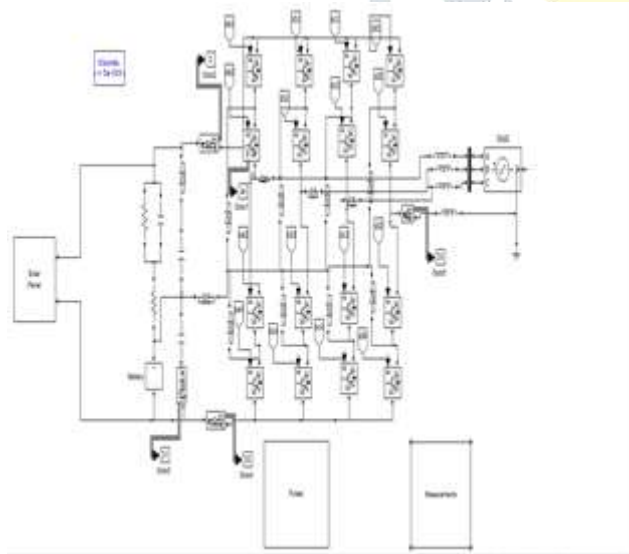

**Fig.4.1.Simulation circuit.**

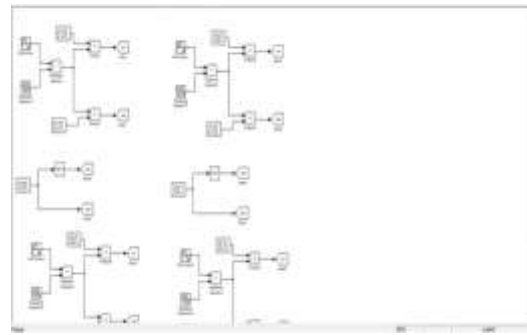

**Fig.4.2. Controller circuit**

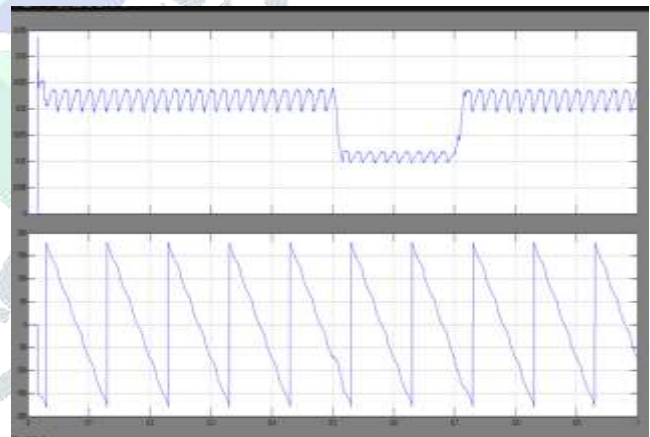
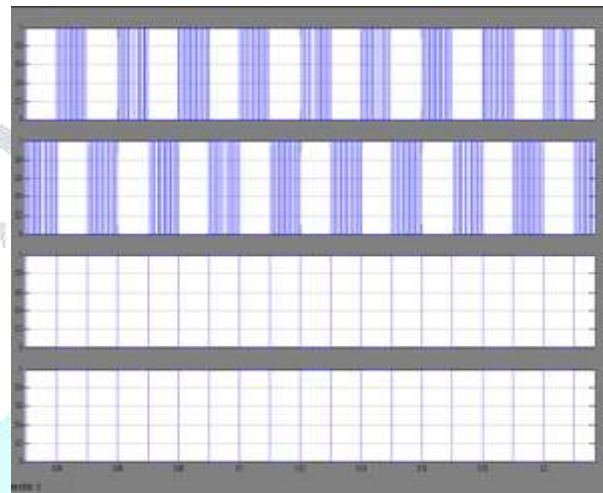

Schematic depiction of the 4-Leg 3LNPC inverter made use of as a HESS user interface for RES and also HESS combination to a microgrid. This geography calls for the RES to be a present resource and also specifically, can be adjusted if put either after a Maximum Power Point Tracking (MPPT) converter for a solar plant, or rather than the grid-side converter of a back to back establish for wind generators. For this research study the RES is taken into consideration as an existing resource infusing right into the DC bus.

## 5. CONCLUSION:

In this paper making use of 4-Leg 3 L-NPC power converter geography to user interface a RES with a HESS (created by a VRB as well as a Li-Ion battery) in a microgrid context has actually been explored. A brand-new version of the architectural restrictions exists and also carried out to manipulate the whole ability of the 4-Leg 3L-NPC converter to guarantee an optimal power department in between both ESS. A non-linear 2-SMC system has actually been created and also tuned to regulate the no series shot in the modulating signals in order to manage the power circulation of the HESS. Additionally, the 4th leg of the converter permits the out of balance lots problem to be dealt with, and also hence allow energetic power filter capacities. The examination of the limitations of the geography revealed a power exchange ability amongst the HESS. Simulation as well as speculative outcomes showed the capability of the suggested control approach to handle a HESS in order to enhance the power top quality and also security along with to regulate the renewable resource infused right into a micro grid.

## REFERENCES:

[1] M. Yekini Suberu, M. Wazir Mustafa, and also N. Bashir, "Energy storage space systems for renewable resource power market combination as well as reduction of intermittency," *Renew. Maintain. Power Rev.*, vol. 35, pp. 499-- 514, Jul. 2014.

[2] S. Vazquez, S. M. Lukic, E. Galvan, L. G. Franquelo, as well as J. M. Carrasco, "Energy Storage Systems for Transport and also Grid Applications," *IEEE Trans. Ind. Electron.*, vol. 57, no. 12, pp. 3881-- 3895,

Dec. 2010.

[3] M. G. Molina and also P. E. Mercado, "Power Flow Stabilization and also Control of Microgrid with Wind Generation by Superconducting Magnetic Energy Storage," *IEEE Trans. Power Electron.*, vol. 26, no. 3, pp. 910-- 922, Mar. 2011.

[4] M.-E. Choi, S.-W. Kim, as well as S.-W. Search engine optimization, "Energy Management Optimization in a Battery/Supercapacitor Hybrid Energy Storage System,"

*IEEE Trans. Smart Grid*, vol. 3, no. 1, pp. 463-- 472, Mar. 2012.

[5] G. Qiu, C. R. Dennison, K. W. Knehr, E. C. Kumbur, as well as Y. Sun, "Porescale evaluation of results of electrode morphology and also electrolyte circulation problems on efficiency of vanadium redox circulation batteries," *J. Power Sources*, vol. 219, pp. 223-- 234, Dec. 2012.

[6] X. Tan, Q. Li, and also H. Wang, "Advances as well as fads of power storage space modern technology in Microgrid," *Int. J. Electr. Power Energy Syst.*, vol. 44, no. 1, pp. 179-- 191, Jan. 2013.

[7] N. R. Tummuru, M. K. Mishra, as well as S. Srinivas, "Dynamic Energy Management of Renewable Grid Integrated Hybrid Energy Storage System," *IEEE Trans. Ind. Electron.*, vol. 62, no. 12, pp. 7728-- 7737, Dec. 2015.

[8] T. A. Smith, J. P. Mars, as well as G. A. Turner, "Using supercapacitors to boost battery efficiency," in *2002 IEEE 33rd Annual IEEE Power Electronics Specialists Conference. Process*, 2002, vol. 1, pp. 124-- 128.

[9] R. A. Dougal, S. Liu, as well as R. E. White, "Power as well as life expansion of battery-ultracapacitor crossbreeds," *IEEE Trans. Elements Packag. Technol.*, vol. 25, no. 1, pp. 120-- 131, Mar. 2002.

[10] T. Zhou and B. François, "Energy management and power control of a hybrid active wind generator for distributed power generation and grid integration," *IEEE Trans. Ind. Electron.*, vol. 58, no. 1, pp. 95--104, Jan. 2011.