

# Virtual Keyboard

SNEHA THORAT<sup>1</sup> PRAJAKTA SURYAWANSHI<sup>2</sup> KALYANI MATE<sup>3</sup> KAVITA JOSHI<sup>4</sup>

<sup>1</sup> DEPARTMENT OF ELECTRONICS AND TELECOMMUNICATIONS,

<sup>1</sup>Dr D.Y Patil Institute of Engineering Management and Research Pune, India.

**Abstract :** As traditional keyboard is bulky and inconvenient to carry , it fails to meet the demand of mobile terminal. In smart devices like Smart phones, tablets etc. a hardware keyboard is missing[1][2]. In order to overcome this the appearance of Virtual Keyboard presented is a new solution for input on portable device. This paper defines a new way of easy handling keyboard by using a smart phone and a paper keyboard (Fig.a) placed on a plane surface and also by using digital image processing . The virtual Keyboard will be done by using a smart phone with IP camera by using some suitable app, where the images will be captured by detecting the key pressed on the paper keyboard[3][4]. Through wifi there will be connection between Smart Phone and laptop/PC. Also the software used is the Matlab software. It will process and detect the character and display on screen and Virtual Keyboard will have an additional feature of voice announcement in the background after every keypress.. Reference[5] also presented virtual keyboard using laser and image processing but the hardware is complex in it. As compared to this in paper the hardware is less complex and it has more accuracy.

**IndexTerms - Smart Phone, Paper Keyboard, Digital Image Processing ,Matlab software etc.**

## I. INTRODUCTION

A proposed System named Virtual Keyboard presented is a new solution for input on portable device which can be handled with ease and efficiency. This project defines a new way of easy handling keyboard by using a smart phone and a paper keyboard placed on a plane surface and also by using digital image processing .



Fig.a

## II.PROBLEM IDENTIFIED –

- 1)As Traditional Keyboard is bulky and inconvenient to carry , it feels to meet the demand of mobile terminal.
- 2) The appearance of Virtual laser keyboard presented is a new solution for input on portable device.

## III.PROPOSED SYSTEM -

This paper defines a proposed System named Virtual Keyboard which can be handled with ease and efficiency. The generalized block diagram (Fig.1), will be consisting of Virtual keyboard i.e the Keyboard drawn on a white paper (Fig.a). After that by using an IP camera present on our Smart phone where the images of the letters pressed on the keyboard will be detected. Also by connecting smart phone to Laptop/ PC through wireless communication. The software used in this paper is Matlab Software , it will process and read the image and display the character on screen. Along with it there will be voice announcement in the background after every keypress. Going into detail of this system the main process includes :- Fig2. First the image will be read from the Virtual Keyboard and the pre-processing is done. Also known as cropping our resizing of image and segmentation is done. After which the image is converted from RGB to Gray scale. After pre-processing the fingertip detection is done. By applying nail colour on nail will detect the fingertip easily. Once fingertip position is located character recognition is done and finally character is displayed on screen. In this way Virtual Keyboard is easy to handle and also has voice announcement on character is presented.

## IV.BLOCK DIAGRAM-

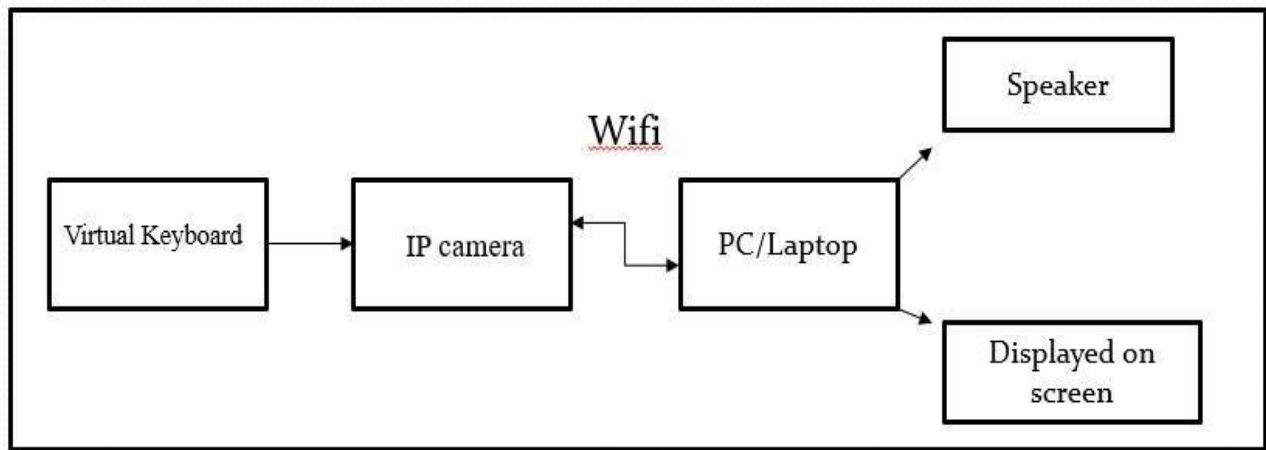

Fig 1: Generalized Block Diagram

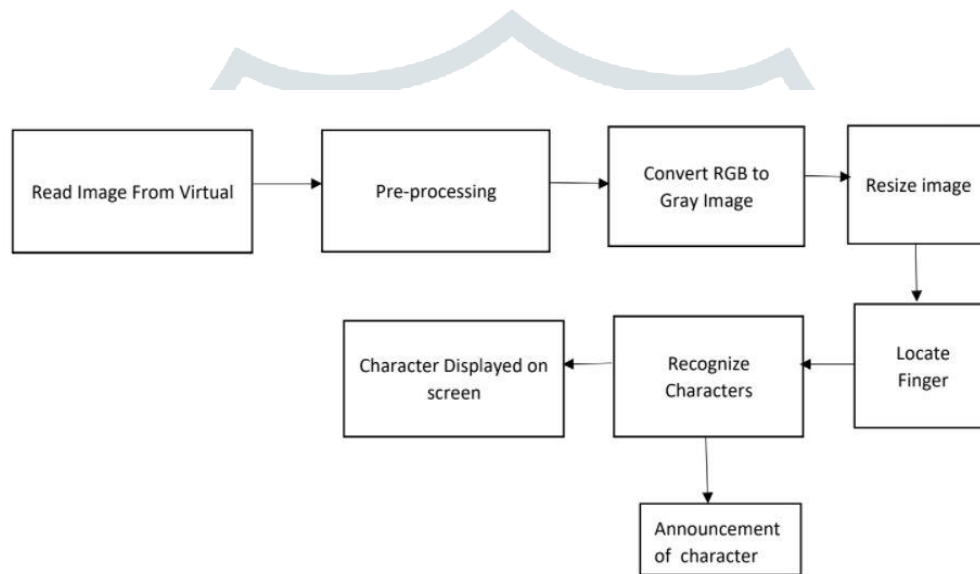

Fig.2: Detailed Block Diagram

## V.OBJECTIVES-

1. To ensure that the Virtual Keyboard designed must have high speed of recognition of letters.
2. To design a less complex system.
3. To make less use of hardware which will automatically reduce cost of the system.
4. To automatically announce the character once the key is pressed on the keyboard.

## VI.CONCLUSION-

Virtual keyboard can be useful for people with handicaps and uses where a few fast keystrokes are required . Exactness and accuracy can be accomplished completely. Also VK is useful in 3D demonstrating, entertainment sector. A virtual keyboard can be utilized to accommodate multiple languages, by simply remapping of characters without any adjustment.

## VII.FUTURE SCOPE-

- 1) In contrast to the past fundamental keyboard, Virtual keyboard has rather more focal points for personalization accommodation and suitable for specific situations.,
- 2) For people with handicaps and uses where a few fast keystrokes are required Virtual keyboards can be of incredible use.
- 3) Also VK can be utilized for applications in virtual reality in entertainment sector,3D demonstrating and so on..

- 4) VK can be utilized to accommodate multiple languages, by simply remapping of characters, with no adjustment in equipment.

## VII. REFERENCES-

- [1]Kölsch M, Turk M,“Keyboards without keyboards: A survey of virtual keyboards, ” Workshop on Sensing and Input for Media-centric Systems, Santa Barbara, CA. 2002.
- [2]Sarcar S., Ghosh S., Saha P. K., Samanta D. “Virtual keyboard design State of the arts and research issues,”.2010 IEEE Students' Technology Symposium (TechSym), Apr. 2010,pp.289-299.
- [3]“Bare-fingers Touch Detection” by the Button’s Distortion in a Projector-Camera System by Jun Hu, Guolin Li, Xiang Xie, Zhong Lv and Zihua Wang.
- [4]“A Camera Based Virtual Keyboard with Touch Detection by Shadow Analysis” by Joseph Thomas, December 10,2013.
- [5]QWERTY Keyboard in Virtual Domain Using Image Processing” by Dr. Pallavi Khare, K. Satya Ram, S. Sourabh, A. Mahender, 2019.
- [6]“Virtual laser keyboards: A giant leap toward human-computer interaction,” 2012 International Conference on Computer Systems and Industrial Informatics (ICCSII), Dec. 2012:1-5.
- [7]Virtual Keyboard: A human – computer interaction device based on laser and image processing . 2015(5<sup>th</sup> Annual IEEE Conference).
- [7] User defined custom virtual keyboard. 2016 Interanational Conference on Info Science(ICIS).
- [8] The application Adaptive Fractional Differential Algorithm in Virtual Keyboard 2017(Chinese control and decision conference(CCDC)).
- [9]QWERTY Keyboard in Virtual domain using Image Processing. 2019 (ICICCS)

