

THE EFFECT OF LATERAL CONNECTION IN MOMENT CARRYING CAPACITY OF FRAME IN LOW-RISE, MID-RISE AND HIGH-RISE RC STRUCTURE BY USING PUSHOVER ANALYSIS

¹ Rohit Ravindra Mahorkar, ² L.G.Kalurkar

¹ PG Student (Structural Engineering), ² Assistant professor,

¹ Department of Civil Engineering,

¹ MGM's JNEC, Aurangabad, Maharashtra, 431002, India.

Abstract :- Now a day's Special Moment Resisting Frames (SMRF) were used as an earthquake resisting structure in Reinforced Concrete structure which are made to stand without any fail or to resist the earthquakes. The Beam-Column Joints, Columns, and Beams in the moment frames are proportioned and detailed as well to resist the shearing, an axial, and flexure which became in result as a construction sways via many ground shaking intense earthquake. The proper proportioning & detailed needs will make a frame capable of resisting strong earthquake without any major loss of strength or stiffness. These Frames which are Resisting the Moment develop due to seismic force are known as "Special Moment Resisting Frame." (SMRF) because of this kind of an extra need, this help to resist seismic force in comparison with much less ductile detailed "Ordinary Moment Resisting frame." (OMRF). The "SMRF" building designing criteria is provided in IS (13920-2002). In this thesis, the buildings are made as "OMRF" and "SMRF" also, and the functionality of these buildings are differentiated. For this purpose, the nonlinear static also known as pushover analysis is carried out by ETABS software on the buildings that modelled. The pushover curve are made from the outcomes of the analysis and also the behavior of designed structures that are inspected for different end conditions and also for different Infill conditions.

Keywords - Nonlinear Static analysis, SMRF, OMRF, Pushover Analysis, ETABS, Plastic Hinges, Response Reduction Factor.

1. INTRODUCTION

Now a days the Earthquake became a worldwide thing. Because on regular basis occurrence of earthquake now it is not more considered as act of God. Throughout the earthquake ground tends to move in both vertical and horizontal direction in uncontrolled manner that makes structure to vibrate and generate inertial forces within them. The Analysis of destroys occurred in moment resisting RCC framed structure put through previous earthquake shows what could be the problems we face because of use of concrete which is not having adequate resistance capability, soft storey, beam-column joint mishap for inapposite anchorage or weak reinforcements, column failure leads to the storey mechanism. Beam-column brace is mostly found as weaker part of structure whenever a system is put through seismic loading. Figures of the column-beam joints and failure collapses in previous seismic activity are shown in Figure 1.1. Thus this kind of column and joint disaster needs to be provided attention.



(A)
(B)



(B)



(C)



(D)

Figure 4.1: Storey mechanism failure of buildings in past earthquakes: -

Figure (A) shows the failure of column with eccentric connection during turkey earthquake, 2003. Figure (B) shows the failure of column and beam-column joint during turkey earthquake, 2003. Figure (C) & (D) shows the failure of building due to column storey mechanism during Bhuj Earthquake, 2001.

Historical Development:-The concrete frame buildings, non-ductile frames, especially older, have frequently experienced considerable structural damage of earthquakes. In beginning of 1960 reinforced cement concrete special moment resisting frame concepts were introduced in the U.S. The use of theirs during that time was basically in the discretion of the designer, as it wasn't until 1973 The Uniform Building Code (ICBO-1973) primarily needed use of the unique frame specifics in areas of greatest seismicity. In India the usage of Special Moment Resisting Frame begun by about 1993. A proper systematic detailing of SMRF in India is based on IS (13920-1993), which after got reaffirmed in the entire year 2002.

The Use of SMRF Structure:-The moment resist frames are generally adopted because of their ability to resist the seismic force when there is flexibility in architectural planning. When concrete frames are choose for structures that are mentioned in Seismic Zone Categories III, IV or perhaps V, the design of the reinforced concrete moment frames should be different by considering the safety through the working period of structure. Proportioning & detailing required for an unmatchable moment frame will grant the frame to easily experience considerable deformations which are expected to be in these seismic layout groups. Specific second frames might be utilized in Seismic Design Categories I or perhaps II, although this might not result in the cheapest design. Both power and stiffness have to be viewed in the design of unique moment frames. Based on IS 13920-2002, specific moment frames are allowed to be designed for a force reduction factor of "R = 5". Moment frames are adoptable lateral systems; thus, by minimizing base shear equations of the codes the need of the strength might be managed.

Theory of Design of SMRF Structure:-The style equations of base shear are present building codes add a seismic force reduction component R, which mirror the inelastic effect anticipated for design level ground motions, and the ductility capability of the frame system. A unique moment resisting frame must be expected to endure several cycles of inelastic response in case it experiences design level ground motion. The proportioning and detailing demands for unique moment frames are supposed to guarantee that inelastic result is ductile.

Three major objectives are:-

To attain a strong column/weak-beam design which spreads inelastic effect more than many stories.

To stay away from shear failure.

To provide details which allow ductile flexural effect in yielding regions.

Strong Column Weak Beam Concept:-Whenever a structure moves during an earthquake, the distribution of damage over height depends upon the distribution of lateral drift. In case the structure has poor columns, drift will focus in a single or maybe a number of stories (Fig 1-2 a), and also could surpass the drift capability of the columns. On the other side, in case columns supply strong spine and a stiff with the construction height, drift is far more uniformly spread (Fig 1-2 c), and localized destruction will be lowered. The sort of failure which is displayed in (Fig 1-2 c) is widely known as Beam Mechanism or even Sway Mechanism. Furthermore, it's essential to understand that columns in a certain story must support the load of the whole structure which acting on those columns, while the beams just help support the gravity lots of the floor of that they create a part; thus, failure of a column is of greater consequence than failure of any beam. To recognize the behavior, of building codes defines which columns be stronger compared to the beams which frame into them. This particular strong-column/weak-beam concept is primary to achieving secure behavior of frames in sever earthquake ground motion. It's a style concept that has got to be absolutely followed while designing Special Moment Resisting Frames.

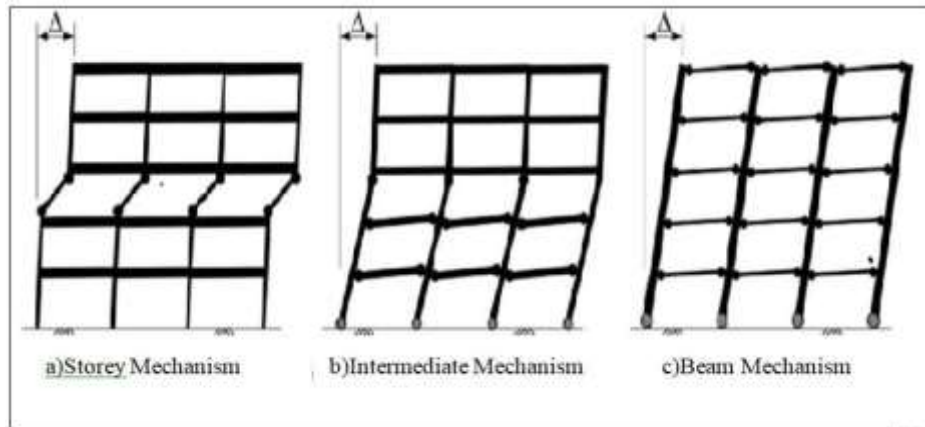

Figure 4.2: Different failure mechanisms

Avoidance of Failure Due to Shear: - Ductile response needs that members yield for flexure, which shear failure be stayed away from. Shear failure, particularly in columns, is comparatively fragile and will result in speedy loss of lateral strength and axial load carrying capacity. Column-shear failure is essentially the most frequently occurs because of concrete construction failure as well as earthquake collapse. Shear failure is stayed away from throughout use of a capacity design approach. The basic strategy is usually to determine flexural yielding regions, style those areas for code required moment strengths, after which compute design shears dependent on equilibrium considering the flexural yielding areas acquire likely moment strengths. The probable second strength is calculated by using procedures which make a top estimation of the second strength of the designed cross section.

Detailing for Ductile Behaviour: - For attaining a ductile characteristics, value have to be provided for the detailing in reinforcement. The different factors which should be look after is discussed below. The ductile nature of the structure is heavily determined by the detailing design and improper detailing might lead to failure of the structure with no sufficient warning.

Bond for Heavily Loaded Sections: - A Plain concrete has fairly little functional compressive strain capability (around 0.003), which may restrict the deformability of column and beam of unique second frames. Strain efficiency may be enhanced tenfold by limiting the concrete with reinforcing spirals or even by closed hoops. The hoops act to resist the expansion of the primary concrete as it's loaded in compression, which confining activity results in enhanced strength and strain capability. Hoops generally are furnished at the column ends, and also via beam column joints, and also at the beam ends. To work, the hoops should enclose the whole cross area except the covering concrete, which ought to be small as allowable, and also should be closed by 135° hooks lodged to the primary concrete; this stops the opening of hoops whether the concrete cover reduce by. Crosstie must engage longitudinal reinforcement within the perimeter to correct confinement effectiveness. The hoops should be strongly spaced across the length of the part, each to limit the concrete and resist buckling of reinforcement in longitudinal direction. Crosstie, that normally have 90° as well as 135° bent hooks to ease the construction, should have their 90° and 135° bent hooks alternated across the length of part to correct confinement effectiveness.

Ample Shear Reinforcement: - The Shear strength reduce in members subjected to a number of inelastic deformation reversals, particularly if axial load are reduced. In members which are such that it's needed the inclusiveness of concrete to resistance to shear be ignored, that's, $VC = 0$. Thus, shear reinforcement is necessary to resist the whole shear force.

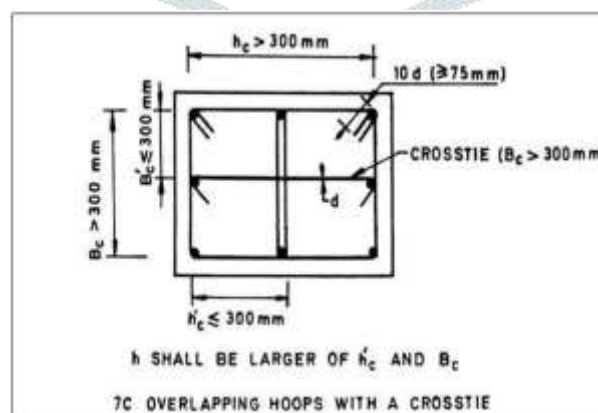

Figure 4.3: Shear reinforce detailing in beam according IS 13920 (2002)

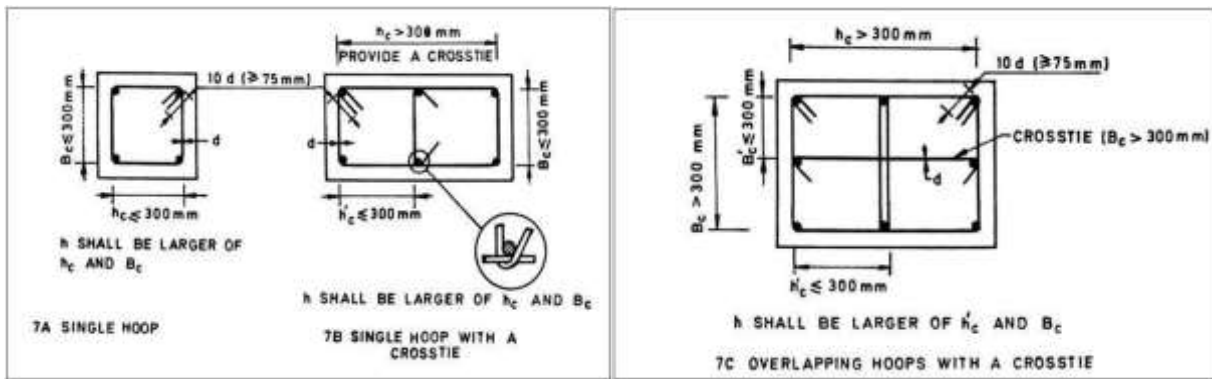

Figure 4.4: Transverse reinforcement in columns as per IS 13920(2002).

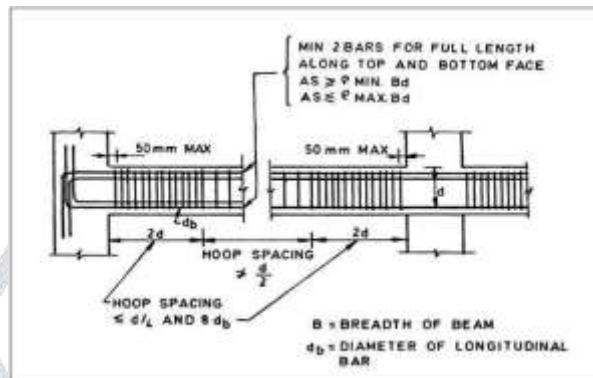

Figure 4.5: Beam reinforcement as per IS 13920(2002).

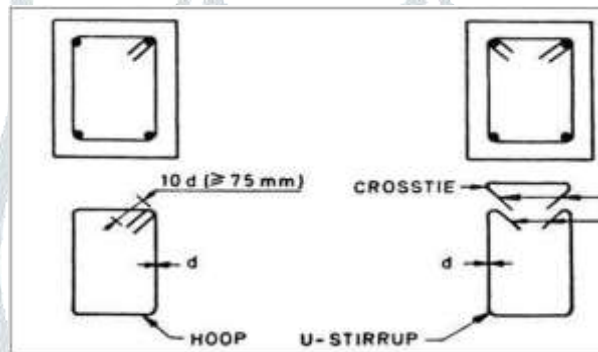

Figure 4.6: Beam web reinforcement as per IS 13920(2002).

Avoidance of Anchorage or Perhaps Splice Failure:-Serious seismic loading is able to lead to loss of concrete cover that is going to reduce growth as well as lap splice strength of longitudinal reinforcement. Lap splices, if used, should be placed from areas of maximum moment (that is, from ends of columns and beams) and also should have closed hoops to limit the splice in the event of cover sapling. Bars passing by way of a beam column joint is able to develop serious bond stress demands on the joint. Bars anchored in exterior joints have to acquire yield strength (FY) using hooks situated at the far aspect of the joint. Lastly, physical splices located where yielding is apt should be splices capable of acquiring a minimum of the specified tensile strength of the bar.

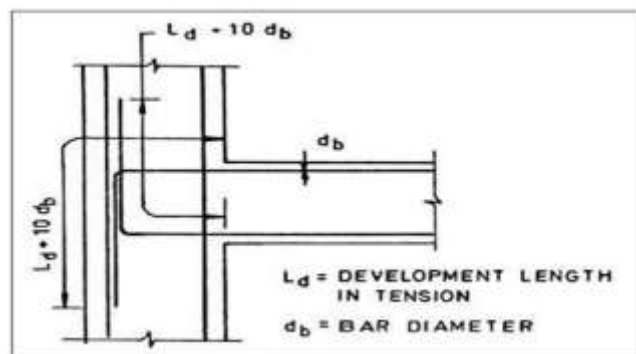

Figure 4.7: Lap Splicing of a beam bars in an external joint as per IS 13920(2002)

PROBLEM STATEMENT:-

The Present study is about to discuss on different angels related to the capability of SMRF buildings. The initial target of current study will be to run the analysis of relative capability of OMRF and SMRF frames, design according to IS codes, using nonlinear analysis. The actual performance of the SMRF and OMRF building involve with modelling and with the geometric properties of the

Infill walls. The verity of the infill walls used in Indian constructions are considerable. Depend on the strength, it could be classified as weak Infill or strong Infill. The two kind of examples of infill walls i.e. weak Infill and strong Infill are considered by modelling the infill wall space as accurate as it could be possible in the current study. The soil type and type of foundation can also affects the behavior of the structures. Found by the foundations constructed on hard or soft soils, with the consideration of fixed or hinged end conditions. As the modelling of soils is not in the range of the research, two boundary conditions, fixed and hinged, which symbolize two extreme conditions, are considered.

OBJECTIVE:-

The objectives of the current study are as follows:-

- As in order to learn the behavior of SMRF and OMRF structures created as per IS codes.
- To learn, study and observe the outcome of some sort of infill walls in order to the functionality of the SMRF buildings.
- To learn and study the effect of support problems i.e. end support on the functionality of SMRF and OMRF.

PROVINCE OF THE STUDY:-

The special moment resisting frame (SMRF) buildings are usually constructed in earthquake prone places as India as they offer higher ductility. Failures which have been noticed in previous earthquakes that indicate the collapse of such structures is predominantly as a result of the development of soft storey mechanism of the ground storey columns.

The following may be considered when the range of the study: -

- The present study works with low-rise, mid-rise & high-rise RC framed Buildings that are regular in plan.
- This analysis is about two different kind of assistance factors normally utilized in design and analysis i.e., repaired and hinged assistance quality. Other kinds of assistance conditions are not considered during this project.

METHODOLOGY:-

The methodology is about to get the above mentioned goals can be as follows: -

- Review the current literature as well as Indian design code provision for developing SMRF and OMRF building & Select a current building for the case study.
- Create the model the selected design with & without considering infill strength/ stiffness. Models have to think about 2 kinds of end support conditions as stated early.
- Nonlinear analysis of the selected building model along with a comparative research on the outcomes from the analyses.
- Observations of discussions and results further recommendation
- Conclusion always keeping the scope of this research in mind.

2. LITERATURE REVIEW

This chapter deals with some amount of studies are been carried out on the related topic with the particular type of results they get through the way of performance. Few of them are reviewed and there salient features are discussed below.

Foley CM. (2002) - Studied an evaluation of recent state-of-the-art seismic performance based design methods and also offered the sight for improvement of PBD optimization. It's realized that there's a pressing need for building optimized PBD process for earthquake engineering of buildings.

R. Hasan and also D.E. Grierson. (2002) - Conducted an easy computer based pushover analysis technique for execution based design of creating frameworks susceptible to seismic loading. And also discovered that rigidity aspect for elastic examination of semi-rigid frames, & the rigidness properties for semi rigid analysis are exclusively used for push over analysis.

B.Akbas. (2003) - A pushover examination executed on steel frame to calculate the seismic needs at distinct performance levels, and that demands the study of inelastic behavior of the framework.

Murthy and Das. (2004) - Found that when infill wall contained inside a framework, usually bring on the damage suffered by the RC framed users of a completely in filled frame during earthquake shaking. The column, beam & also infill walls of reduced accounts tend to be more susceptible to damage than all those in upper stories.

Oguz, Sermin. (2005) - Ascertained the accuracy and the consequences of never changing lateral load paradigm employed in pushover examination to foresee the behavior required on the framework as an outcome of randomly Selected unique ground motions producing elastic deformation by learning several levels of Nonlinear response. For this particular objective, pushover analyses applying different never changing lateral load paradigm and Modal Pushover examination had been carried out on reinforced concrete and also metal moment resisting frames covering an extensive selection of basic periods. The precision of approximate Process used to forecast ideal displacement had also been examined on frame structures. Pushover analyses were carried out by both ETABS and DRAIN-2DX. The main observations from the analysis demonstrated that the precision of the pushover outcomes depended highly on the load course, the qualities of the ground motion and also the attributes on the framework.

X.-K. Zou. (2005) - Presented a highly effective method that features Pushover Analysis combined with numerical optimization process to automate the Pushover carry performance design of reinforced concrete buildings. PBD by utilizing nonlinear static pushover analysis, that typically involves tedious computational effort, is very iterative procedure had to fulfill code requirements.

Kircil. (2006) - Designed 3, 5 and 7 storey structures based on Turkish Design codes and discovered that the fragility curve has extensive variations based on the height of the structure.

Asokan (2006) - Studied just how the existence of infill walls in the building frames changes the lateral strength and rigidity of the framework. This research approached a plastic hinge model for infill wall surface to be widely used in nonlinear performance based evaluation of a construction and also concludes the ultimate load approach together with the suggested hinge home offers a much better estimation of the inelastic drift of the structure.

Mehmet. (2006) - Explained that because of its simplicity of Pushover analysis, the structural engineering field is using the nonlinear static procedure or maybe pushover analysis. Pushover analysis is performed for various nonlinear hinge properties offered in certain applications depending on the ATC-40 and FEMA-356 guidelines and he pointed out that Plastic hinge length (LP) has extensive results on the displacement capability of the frames. The orientation and also the axial load amount of the columns can't be taken into consideration properly through the default hinge properties (Programmed Default).

Girgin Holmes. (2007) - Author tells about Pushover analysis continues to be the preferred way of seismic performance analysis of buildings by the main rehabilitation guidelines and codes since it's conceptually and computationally simple. Pushover analysis permits tracing the tertiary of yielding & failure of member & structural level along with the development of capacity curve of the framework.

Shuraim, A. Charif. (2007) - Explained the nonlinear static examination process (Pushover) as mentioned by ATC 40 happens to be used for the analysis of current look associated with a brand new RC frame. Potential structural faults in RC frame, when put through a reasonable seismic loading, were approximated by the pushover approaches. In this process the style was examined by redesigning under selected seismic mixture in an effort showing what members would involve additional reinforcement. Most columns needed significant more reinforcement, indicating their unsafety when put through seismic forces. The nonlinear pushover process indicates the frame is effective at resisting the assumed earthquake pressure with a few substantial yielding at all the beams as well as a single column.

A.Kadid. Boumrkik. (2008) - Proposed use of Pushover Analysis like a viable way to assess damage vulnerability of a construction created based on Algerian code. Pushover evaluation was a number of incremental static analyses completed to create a capacity curve for the construction. Based upon capacity curve, a target displacement that was estimation on the displacement that the design earthquake would generate on the structure was determined. The scope of damage that is happening to the framework at this particular target displacement is symbolic of the damage encountered by the structure when put through design level ground shaking. Since the Behavior of reinforced concrete buildings may be extremely inelastic under seismic a lot, the worldwide inelastic overall performance of RC structures will be dominated by plastic yielding effects and consequently the accuracy of the pushover analysis will be affected by the capability of the Analytical designs to record these side effects.

Athanassiadou. (2008) - Analyzed 2 ten-storied 2D stepped frames along with definitely one ten-storied typical frame created, as per Euro code 8 (2004) just for the higher and moderate ductility classes. This analysis validates the style methodology requiring linear powerful analysis recommended in Euro code eight for unusual buildings. The stepped buildings, created to Euro code 8 (2004) have been discovered behaving satisfactorily under the style foundation earthquake and under the optimum considered earthquake (involving ground motion doubly powerful as the design basis earthquake). Inter-storey drift ratios of irregular frames have been found to stay very low maybe even in the case of the "collapse prevention" earthquake. This point, put together with the minimal plastic hinge formation in columns, exclude the risk of development of a collapse mechanism at the neighborhood of the problems. Plastic hinge formation in columns is seen being quite restricted during the style foundation earthquake, going on just at locations not prohibited by the code, i.e. within the construction foundation and top. It's been realized that the capability design process offered by Euro code eight is totally successful and also can certainly be recognized by conservatism, largely in the case of the style of high ductility columns. The over strength of the irregular frames is discovered to be much like that of the standard types, with the over strength ratio values being 1.50 to 2.00 for medium - high ductility levels. The creator given the end result of pushover analysis using "uniform" load pattern and a "modal" load pattern which account the end result of multimodal elastic evaluation.

Karavasilis. (2008)-Presented a parametric research of the inelastic seismic response of plane steel moment resisting frames with setbacks and steps. A family of 120 such frames, created based on the European seismic & structural codes, had been put through 30 earthquake ground motions, scaled to various intensities. The primary results of this particular newspaper are as follows. Inelastic deformation and also geometrical configuration play a crucial role on the height wise distribution of deformation demands. Generally, the max deformation demands are concentrated within the tower base junction in the situation of setback frame and in all of the action places within the case of stepped frames. This focus of forces at the places of height discontinuity, nonetheless, is not found in the flexible selection of the seismic response.

Tena-Colunga. (2008) -Conducted an investigation on 22 regular mid-rise RC SMRF buildings to satisfy the demands of MFDC (Mexico Federal District code) and also realized that use of secondary beams to minimize the slab thickness can lead to increased seismic behavior in SMRF.

Taewan K. (2009) -Designed a building as per IBC 2003 and also demonstrated that the structure satisfied the inelastic behavior meant in the code and pleased the style drift limit.

Abbie and Sattar. (2010) -In their study concluded that the pushover analysis confirmed a rise in energy dissipation, strength, and initial stiffness of the infill frame, when compared with the bare frame, despite the wall's brittle failure modes. Likewise, dynamic analysis results suggested that fully infill frame has probably the lowest collapse risk as well as the blank frames have been found to be most vulnerable to earthquake induced collapse. The far better collapse overall performance of fully infill frames was involving the bigger energy and strength dissipation of the device, connected with the additional walls.

Duan.H. (2012) -Created a five story RC frame building based on Chinese Seismic codes and investigated the seismic functionality of the identical by pushover analysis and also discovered the possibility for a gentle story mechanism under substantial seismic loads.

Haroon Rasheed Tamboli and Umesh N. Karadi. (2012) -Performed seismic analysis using Equivalent Lateral Force Method for many different reinforced concrete (RC) frame building models which included blank frame, in filled frame and wide open initial story frame. In modelling on the masonry Infill panels the Equivalent diagonal Strut method was utilized and also the software was employed for the evaluation of all of the frame models. In filled frames must be chosen in seismic areas than the wide open very first story frame, since the story drift of original story of wide open first story frame is extremely big than top of the stories, that may most likely result in the collapse of building. The infill Wall boosts the power and stiffness of the framework. The seismic analysis of RC (Bare frame) structure lead to under estimation of base shear. Therefore different response numbers including time period, all natural frequency, and story drift weren't substantial. The under estimation of base shear may well result in the collapse of structure during earthquake shaking.

Summary

In this chapter the many numbers of papers and journals that is been found useful for implementing the efforts. A considerable literature review with the presumption is mentioned down. From numerous scientific studies it is said that ductile detailing is essential to withstand earthquakes. Many works are completed about buildings with ductile detailing, but there was quite less amount of works evaluating the functionality of OMRF and SMRF Moreover, no works was achieved before primarily based on IS codes. The second chapter struggles with the specifics on the layout of structures and also the kind of analysis that must be taken out. A comprehensive explanation about pushover analysis & plastic hinges is discussed about within the coming chapter.

3. CONCLUSION

The efficiency analysis of buildings designed as Special Moment Resisting Frame (SMRF) Ordinary Moment Resisting Frame (OMRF) is analyzed for a number of building configurations, infill problems in addition to help conditions. The buildings are meant and in addition modelled utilizing computational software. Nonlinear analysis is completed on these buildings and the response are monitored. A pushover curve with Base Shear versus Roof Displacement is plotted for each frame while utilizing evaluation data. Several comparative scientific tests are carried out to understand the behavior of SMRF and OMRF.

- It is observed that for OMRF & SMRF as the height of the building increases the Base Shear increases.
- For fixed support The Base Shear of SMRF building of 3 bays is more than OMRF building of 3 bays. The percentage increase in Base shear for SMRF is from 81 % to 90 %.
- For fixed support The Base Shear of SMRF building of 6 bays is more than OMRF building of 6 bays. The percentage increase in Base shear for SMRF is from 75 % to 99 %.
- For fixed support when the bay width and storey height is nearly equal, the roof displacement decreases for SMRF structure and when the storey height and bay width are unequal then roof displacement increases.
- For Hinged support the increase in Base Shear for SMRF structure is nearly same for all height of buildings having same number of bays.
- For Hinged support The Base Shear of SMRF building of 3 bays is more than OMRF building of 3 bays. The percentage in Base shear for SMRF is from 68 % to 65 %
- For Hinged support The Base Shear of SMRF building of 6 bays is more than OMRF building of 6 bays. The percentage in Base shear for SMRF is from 44 % to 39 %.
- For Hinged support The Roof displacement of SMRF structure of 3 bays decreases from 23 % to 27 % . & for 6 bays it increases from 23 % to 27 %.
- In comparison of SMRF structure for FIXED & HINGED support it shows that the Base Shear and Roof Displacement for FIXED support is better than HINGED support.
- In the storey wise comparison of SMRF structure with fixed support conditions and no infill it is found that 15S6B SMRF is better than the 9S6B & 12S6B SMRF structure.
- In bay wise comparison of SMRF structure with fixed support conditions and no infill it is found that 9S6B SMRF is better than 9S3B SMRF structure.
- In comparison of SMRF structure with Strong and Weak Infill for FIXED support condition. The base shear & roof displacement for Strong and Weak infill wall structure does not affect that much, so we can say that the type of infill walls does not affect the base shear & roof displacement.
- However for the better and correct results our input details should be correct, any wrong inputs of the details may lead to the wrong results.
- Also while performing such analysis on the software proper knowledge of the software is require any wrong input given may lead to the wrong results that will affect the study of the structures.

Although pushover analyses offers an insight about nonlinear behavior imposed on structure by seismic activity, pushover analyses were not in a place to reasonably make neither the actual sequence of hinging nor the places of theirs in cases that are many. So,

seismic evaluation process and also style have to be performed by constantly keeping in the mind of yours that specific degree of variation generally prevails in seismic demand prediction of pushover analysis.

Lastly, a lot more systematic and finish parametric scientific tests, looking at several times, power proportions, and earthquake ground motions, nonetheless, will be expected to create specific standards for efficient design of reinforced concrete specific moment resisting frame system.

4. REFERENCES

1. Foley CM. (2002), "Optimized performance-based design for buildings. Recent advances in optimal structural design", American Society of Civil Engineers; p. 169– 240.
2. Hasan, R., Xu, L., & Grierson, D. E. (2002), "Push-over analysis for performance based seismic design", 80(July), 2483–2493.
3. Akbas, B., Kara, F.I., and Tugsal, U.M. (2003), "Comparison of Pushover Analysis and Nonlinear Dynamic Time History Analysis on Low-, Medium-, and High-Rise Steel Frames", Project No. 02-A-02-01-03, Scientific Research Project Fund, Gebze Institute of Technology
4. Murty, Das C. V. R. (2002), "Performance of reinforced concrete frame buildings during 2001 Bhuj earthquake", Proceedings of the 7th US National Conference on Earthquake Engineering. Boston. USA. Paper No. 745.
5. Sermin Oguz. (2005), "A thesis on "Evaluation of Pushover Analysis Procedures for Frame Structures", April, 2005.
6. X.-K. Zou, C.-M. Chan.(2005), "Optimal seismic performance-based design of reinforced concrete buildings using nonlinear pushover analysis", Department of Civil Engineering, Hong Kong University of Science and Technology, Kowloon, Hong Kong, China
7. Kirçil, M. S., and Z. Polat (2006), "Fragility Analysis of Mid-Rise R/C Frame Buildings", Engineering Structures, 2006, 28(9):1335-1345
8. Asokan, A., (2006) Modelling of Masonry Infill Walls for Nonlinear Static Analysis of Buildings under Seismic Loads. M. S. Thesis, Indian Institute of Technology Madras, Chennai
9. Mehmet Inel, Hayri Baytan Ozmen.(2006), "Effects of plastic hinge properties in nonlinear analysis of reinforced concrete buildings", Department of Civil Engineering, Pamukkale University, 20070 Denizli, Turkey.
10. Girgin Holmes, M. (1961), "Steel frames with brick and concrete infilling. Proceedings of Institution of Civil Engineers", 19. 473-478.
11. Shuraim, A. Charif, (2007) Performance of pushover procedure in evaluating the seismic adequacy of reinforced concrete frames. King Saud University
12. A.Kadid. Boumrkik ATC 40, (1996), "Seismic Evaluation and Retrofit of Concrete Buildings", Applied Technology Council, USA.
13. Athanassiadou CJ. (2008), Seismic performance of R/C plane frames irregular in elevation. Engineering Structures 2008;30:1250
14. Karavasilis TL, Bazeos N, Beskos DE. Seismic response of plane steel MRF with setbacks: estimation of inelastic deformation demands. J Constr Steel Res 2008; 64:64454.
15. Tena-Colunga, A., Correa-Arizmendi, H., Luna-Arroyo, J. L., & Gatica-Avilés, G. (2008). Seismic behavior of code-designed medium rise special moment-resisting frame RC buildings in soft soils of Mexico City. Engineering Structures, 30(12), 3681–3707.
16. C. V. R. (2002), "Performance of reinforced concrete frame buildings during 2001 Bhuj earthquake", Proceedings of the 7th US National Conference on Earthquake Engineering. Boston. USA. Paper No. 745.
17. Duan, H., & Hueste, M. B. D. (2012). "Seismic performance of a reinforced concrete frame building in China". Engineering Structures, 41, 77–89.
18. IS: 13920, (2002), "Indian Standard Code of Practice for Ductile Detailing of Reinforced Concrete Structure Subjected to Seismic Forces", Bureau of Indian Standards, New Delhi.
19. IS: 1893 Part 1, (2002), "Indian Standard Criteria for Earthquake Resistant Design of Structures", Bureau of Indian Standards, New Delhi.
20. IS: 456 (Fourth Revision), (2000), "Indian standard code for practice for plain reinforced concrete for general building construction", Bureau of Indian Standards, New Delhi.
21. IS: 875 Part 1, 2, 3 and 4, (1987), "Indian Standard Code of practice for Design loads for buildings and structures", Bureau of Indian Standards, New Delhi.