

Analysis of the Double Tube Heat Exchanger with Fins

¹Piyush Kumar Bharti, ²Saumitra Sharma

¹M.Tech Scholar, ²Assistant Professor

^{1&2}Department of Mechanical Engineering

^{1&2}Oriental College of Technology, Bhopal, India

Abstract : Heat exchanger is a device which is used for exchange of heat from one fluid to another fluid. There is so many methods to exchange heat in fluid i.e direct contact and indirect contact. In direct contact hot fluid directly mix up with cold fluid while in indirect contact fluid will be separate by solid wall/pipe which prevent to mixing. In this research work we use concentric tube in which concentric pipe, one inside and another outside which prevent to mixing of fluid. Basically as increasing surface area rate of heat transfer increase but it is not possible to increase surface area in small and medium industry. As we see that problem, we used double concentric pipe to increase rate of heat transfer fastly. Fins are attached with inner pipe to enhance rate of heat transfer, performance and reduce surface area. In this work the performance of heat exchanger which setup with fin and without fin are compared on the basis of LMTD and heat transfer coefficient with the help of CFD. It is impossible to calculate all this parameter by paper pen so with the help of ANSYS FLUENT 2021R1 easily analysis this research work. Finally we work on heat transfer rate of heat exchanger to increase after attached fins.

IndexTerms - Heat Exchanger, Cfd, Ansys Fluent, LmtD, Fins, Friction Factor, Heat Transfer Rate.

I. INTRODUCTION

A heat exchanger is a device that is used to transfer thermal energy (enthalpy) between two or more fluids, between a solid surface and a fluid, or between solid particulates and a fluid, at different temperatures and in thermal contact. The exchange can take place between a process stream and a utility stream (cold water, pressurized steam, etc), a process stream and a power source (electric heat), or between two process streams resulting in energy integration and reduction of external heat sources. Typically, a heat exchanger is used with two process streams. However, multi stream heat exchangers are sometimes used with energy extensive processes, such as LNG processing, to reduce capital cost.

The term heat exchanger applies to all equipment used to transfer heat between two streams. However, the term is commonly used to equipment in which two process streams exchange heat with each other. In the other hand, the term heater or cooler is used when the exchange occurs between a process stream and a plant service stream. Other terms used to describe heating equipment include: vaporizer and reboiler (for vaporization) and evaporator (for stream concentration). Exchangers can also be classified as fired (heat source is fuel combustion) and unfired exchangers.

There are many types of heat exchangers applied in the process industry. These types include:

1. Hairpin/Double pipe exchangers
2. Shell and tube exchangers
3. Plate and frame exchangers
4. Plate-fin exchangers
5. Spiral heat exchangers
6. Air coolers and condensers
7. Direct contact (quenching towers)
8. Fired heaters

The selection of a heat exchanger depends on many factors including capital and operating costs, fouling, corrosion tendency, pressure drop, temperature ranges, and safety issues (tolerance to leakage). In process calculations, the main objectives of heat exchanger calculations are to determine the heat duty (amount of energy to be transferred), temperature changes within the exchanger, and pressure drops. Depending on the degree of details available/needed, the calculations might be simple or thorough. For an exchange with a hot stream and a cold stream, the heat requirements are calculated as:

$$Q=m\Delta H=mc_p(T_{in}-T_{out})$$



Figure 1: Double pipe heat exchanger

$$Q=UA\Delta T$$

with being the overall heat transfer coefficient, the heat transfer area, and is the log-mean temperature difference. Equation is used when simple counter or co-current flows exist. If the flow pattern is more complex (such as the case with most shell and tube heat exchangers), then a correction factor (f) term is used and the equation becomes: $Q=UAf\Delta T$ The overall heat transfer coefficient represents the ease with which heat is transferred from one medium to another. For example, when heat is being transferred from a hot fluid inside a tube to a cold fluid outside of the tube (as shown in Figure 2), the overall heat transfer coefficient is:

$$U=1/R_1+1/R_2+1/R_3$$

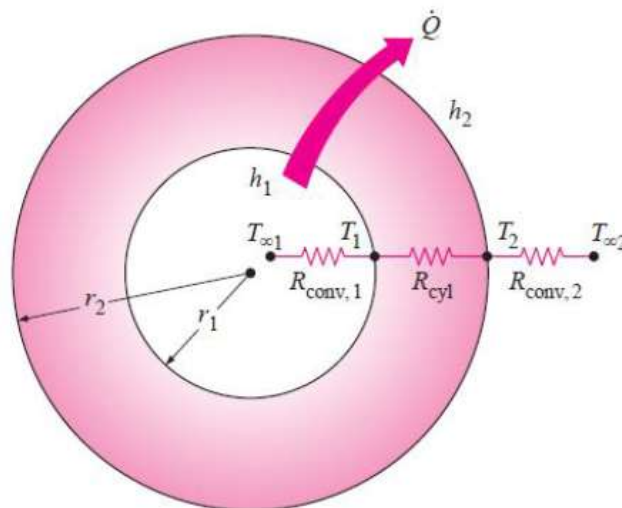

Figure 2: Heat transfer to tube

With R_i being the resistance to heat transfer through each interface (hot fluid-inner tube wall, inner tube wall-outer tube wall, and outer tube wall-cold fluid). The resistance calculation depends on the phase from which heat is being transferred. For R_1 example, for (transfer at fluid-solid interface) the resistance is given by:

$R=1/2\pi Lh$ and for (transfer through solid media), the resistance is given by:

$$R=\ln(r_1/r_2)/2\pi Lk$$

II. DOUBLE TUBE HEAT EXCHANGER

In current scenario so many method to recover unwanted heat just like in shell and tube heat exchanger etc. It is not possible for medium and small industry to effort large volume, low heat transfer performance and high manufacturing cost in shell and tube heat exchanger. We need to required improvement in heat transfer rate and decrease the metal consumption and reduce the operating cost. Double tube heat exchanger with fin of different types is introduced. Most of fin type heat exchanger has complicated structure mainly internal finned type heat exchanger is not suitable for exhaust gas recover system. Main disadvantage is soot deposit inside a inner section of heat exchanger and it will reduce the efficiency of heat exchanger. As internal fins will produce huge large pressure drops in tube as on comparing with the smooth tube which has similar Reynolds number. If the fin configuration is complex then the pumping power increase in the tube side of the internal fins.

Therefore, they're troublesome to plant in existing process as a section of reworking project as a result of the fan in original exhaust facility cannot offer further pressure head to make sure the changed system running ordinarily. The thermal loss by the furnace is account approximately 30-50% and 3-8% of the total energy input of the power plant. In the double tube heat exchanger the fin with flower shape are presented in which the configuration of the fins are not complex. The heat transfer enhancement does meet the requirement. The increment of pressure drop inside the tube is not very serious.

Methods to increase heat transfer in heat exchanger

There basic equation of heat exchanger is as follow

$$Q = UA\Delta T$$

Where,

U is the overall heat transfer coefficient of the heat exchanger.

A is the total heat transfer area.

ΔT is the entering and exiting fluid temperature difference.

Improving heat exchanger performance is accomplished by increasing U, A, ΔT , or a combination of the three. There is six methods to increase the heat transfer in heat exchanger are as follow.

1. Operating pressure-

We know that the ideal gas law ($PV=nRT$). This can be rewritten as $P=\rho rT$, where ρ represents fluid density. From this relationship, we conclude that operating pressure is directly related to density. Further, the pressure drop of a fluid through a heat exchanger

Directly relates to velocity, and is inversely proportional to density. As a result, for a given pressure drop, operating at higher pressures enables higher velocity, yielding higher heat transfer coefficients through higher Reynolds's number.

2. Operating temperature-

Elevating operating temperature can increase heat capacity, thermal conductivity and viscosity.

Entering temperature difference-

In the given heat exchanger if U and A are fixed the performance of heat exchanger can be increase by increasing the temperature difference between the entering of cold and hold fluid.

3. Enhanced surface-

For enhanced the surface area fins should be used. Fin are extended surface whose primary purpose is to increase the surface area for heat transfer from the body.

III. METHOD

Methodology provides the step by step information for achieving the goal & objective. The methodologies in the form of flow chart for analytical & software approaches also provides the overview of the way to achieve the objective The proposed methodology to achieve the goal of study is presented below in Figure-

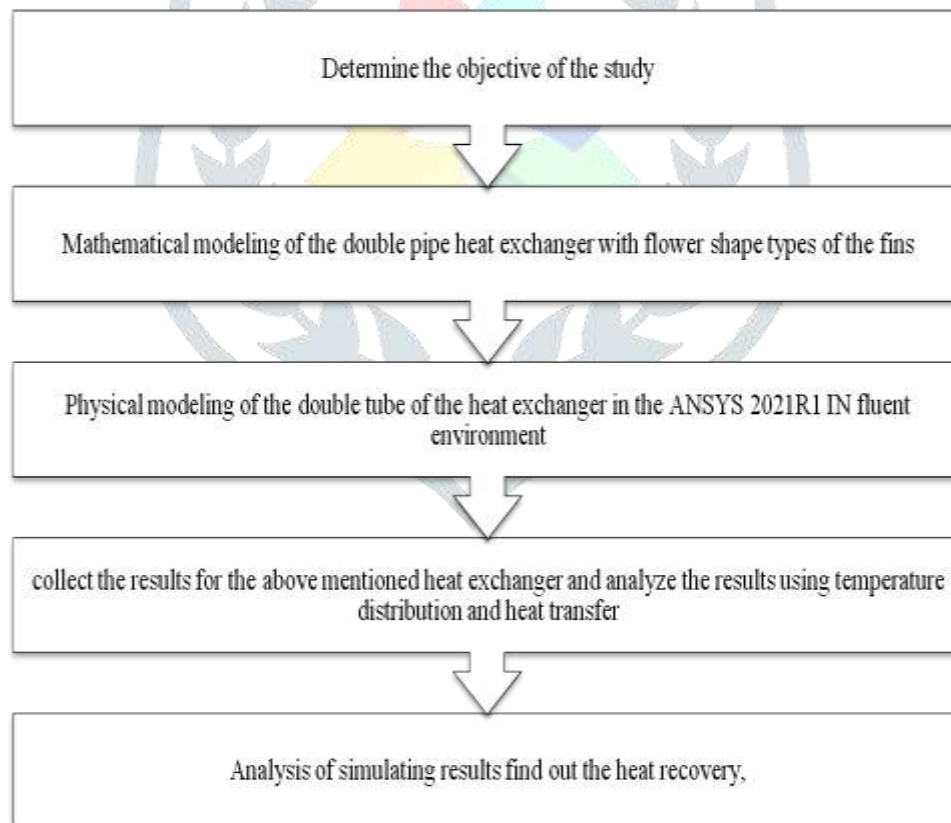

IV. RESULTS AND DISCUSSION

To analyse the performance of the heat exchanger there is two techniques

1. Experimental
2. Numerically

Temperature contour of the double tube heat exchanger-

The variation of the temperature on the concentric double tube heat exchanger is as follow. The dark blue colour shows that minimum temperature of the fluid. The dark red colour show that the maximum temperature of the fluid. range of the temperature contour is 305.5K to 329 K

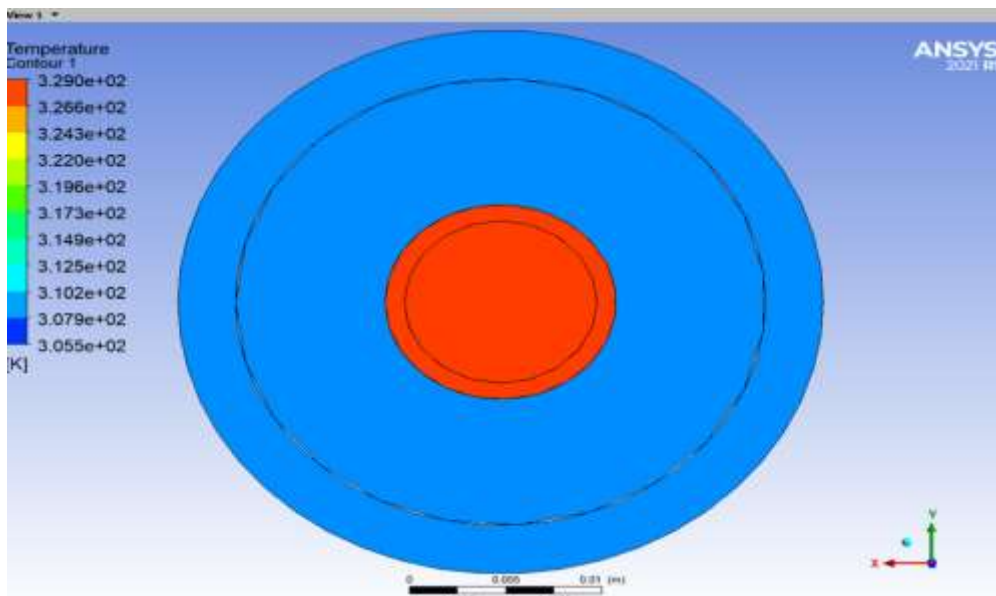

Figure 3: Temperature Contour of the Concentric Double Tube Heat Exchanger

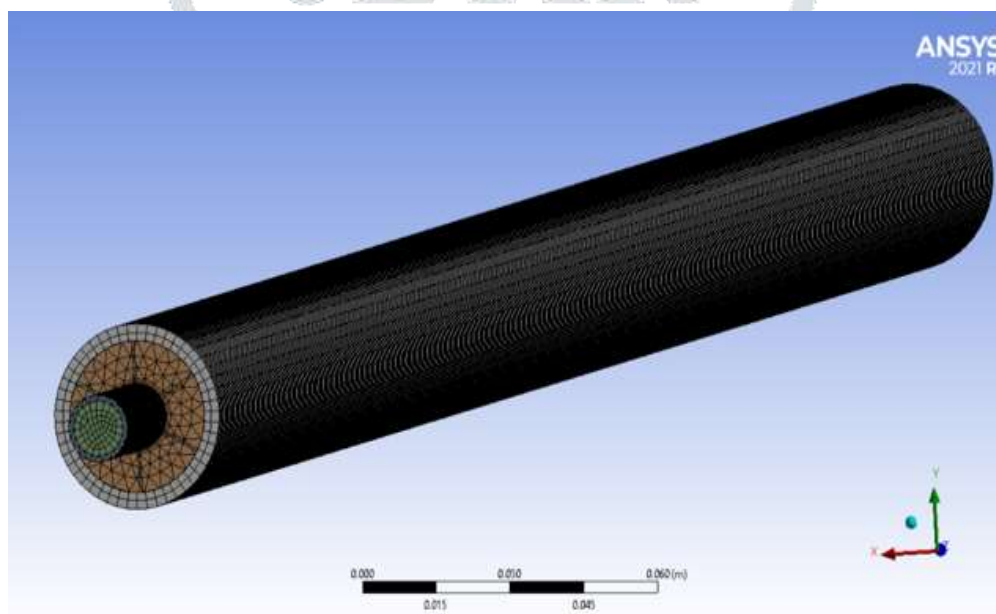

Figure 4: Meshing of the Concentric Double Tube Heat Exchanger

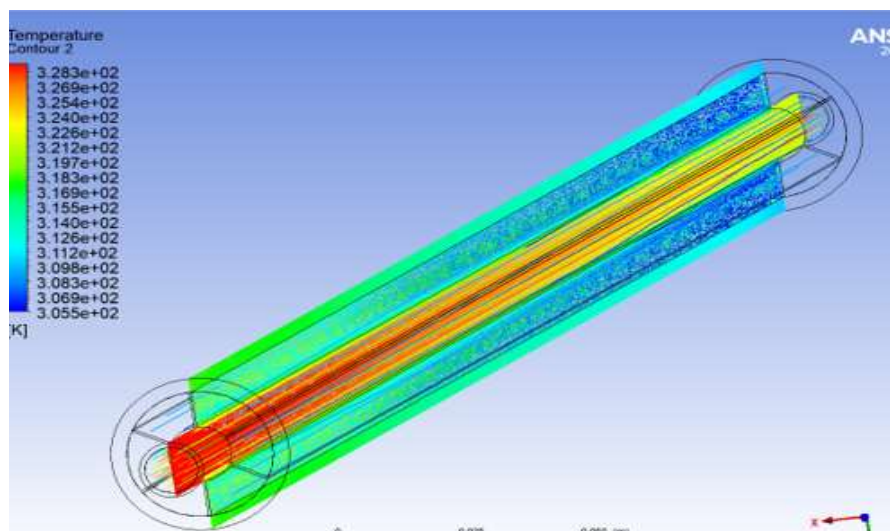

Figure 5: Temperature Contour of the Concentric Double Tube Heat Exchanger

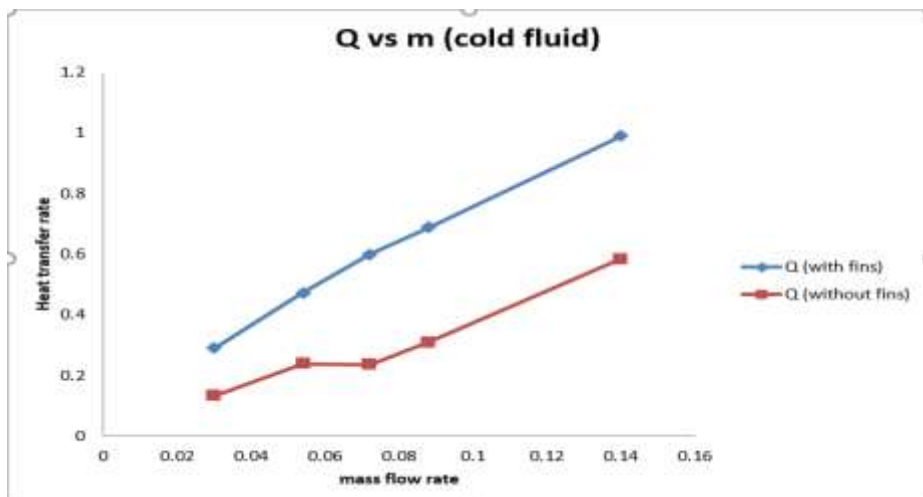

Figure 6: Variation of the mass flow rate verses heat transfer rate in cold fluid

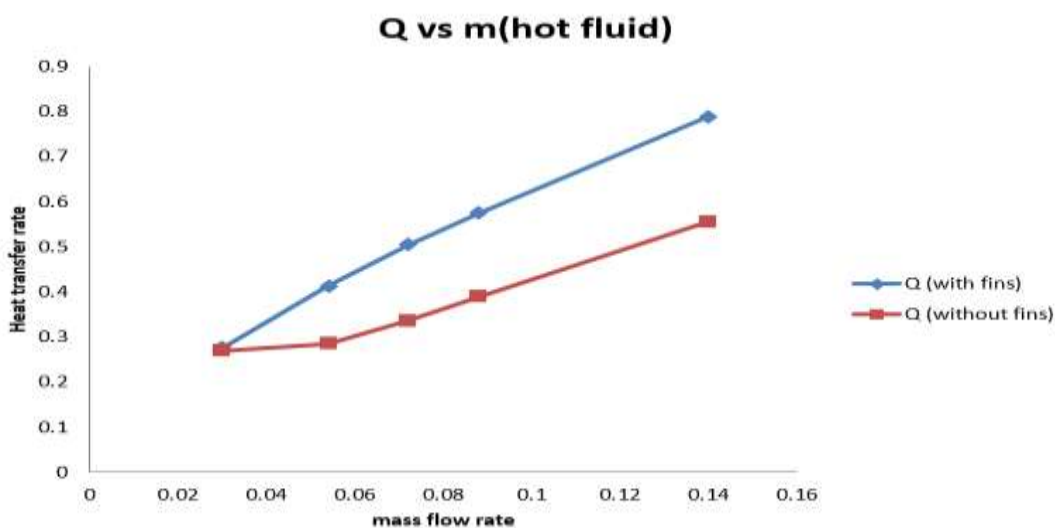

Figure 7: Variation of the mass flow rate verses heat transfer rate in hot fluid

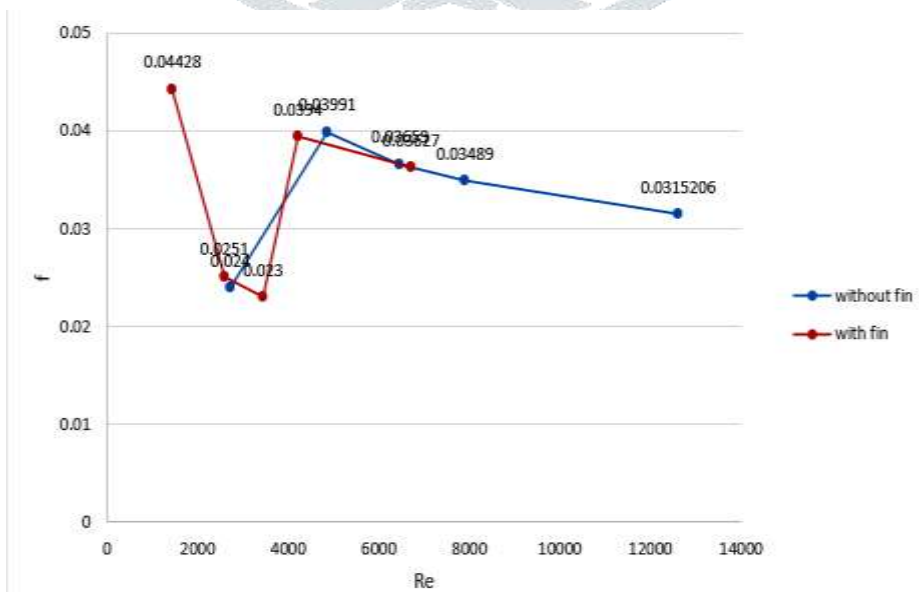

Figure 8: Variation of friction verses Reynolds number

Comparison of the heat transfer of the double concentric tube heat exchanger with fins and without fins for different mass flow rate-

From the basic theory of the heat exchanger so many ways to increase the 'Q'(heat transfer) one of it is increase area of the heat exchanger. On increase the surface area, fins are implementing inside a tube and effect of the fins in a heat exchanger is analysed and also for different mass flow rate by using ANSYS 2021R1 fluent environment.

The heat transfer rate is calculated from the following equation-

$$Q = c_p m (T_{in} - T_{out})$$

Where Q is heat transfer rate of fluid.

m is mass flow rate of fluid.

In the following table the 'Q' is tabulated for the both condition of the heat exchanger.

Q on the different 'm' in with fins as shown in table

s. no.	Mass flow rate	Hot fluid(inlet temperature)	Hot fluid(outlet temperature)	Q (Heat transfer rate)	Cold fluid(inlet temperature)	Cold fluid(outlet temperature)	Q (Heat transfer rate)
1	0.03	329	319.833	0.27638	305.5	315.1167	0.2899
2	0.054	329	321.38513	0.4132	305.5	314.2044	0.4723
3	0.072	329	322.018	0.50515	305.5	313.78191	0.5992
4	0.088	329	322.497	0.5750	305.5	313.29211	0.6891
5	0.14	329	323.397	0.7884	305.5	312.565	0.9899

Q on the different 'm' in with fins as shown in table

S. no.	Mass flow rate	Hot fluid (inlet temperature)	Hot fluid (outlet temperature)	Q (Heat transfer rate)	Cold fluid(inlet temperature)	Cold fluid(outlet temperature)	Q (Heat transfer rate)
1	0.03	329	320.049	0.26987	305.5	309.963	0.1345
2	0.054	329	323.7453	0.28517	305.5	309.903	0.2389
3	0.072	329	324.3424	0.33702	305.5	309.847	0.2359
4	0.088	329	324.597	0.38934	305.5	309.789	0.3103
5	0.14	329	325.0465	0.5559	305.5	309.657	0.5849

V. CONCLUSIONS

According to analysis of the double concentric tube heat exchanger with fins and without fins it is noted that it is always beneficial to use heat exchanger which is equipped with fins. Q in without fin is 0.5849 kJ/sec. and 'm' is 0.14. Q by using fins is 0.9899 kJ/sec. and 'm' is 0.14. The material for the concentric double tube heat exchanger is steel because it is cheaper and rough use. The scrutiny of heat exchanger with fins and without fins for similar 'm' is also found that for higher 'm' increase 'Q' in fins

as compare to without fins. The analysis is also done on different 'm' and see the effect of the temperature distribution in concentric double tube heat exchanger. On increasing the 'm' friction factor should be minimize. Optimize the number of fins used in concentric double tube heat exchanger. Different material for the concentric double tube heat exchanger is used for study. Change the width of the fin for future study.

REFERENCES

- [1] Bandu A.mule et.al. "Analysis of double pipe heat exchanger with helical fins." International Research Journal Engineering and Technology. (2017) vol.4, Pp. 961-966.
- [2] Shiva kumar et.al. "Numerical study of heat transfer in a finned double pipe heat exchanger." World journal of Modeling and Simulation. (2015) vol.11, Pp. 43-54.
- [3] Monica J. Indhe et.al. "Optimization of longitudinal fin profile for double pipe heat exchanger." International Research Journal Engineering and Technology. (2015) vol.2, Pp. 517- 529.
- [4] M.j. scott et.al. "A parametric analysis of the performance of internally finned tube for heat exchanger application" (2009) Pp. 38-43.
- [5] Mayank bhola et.al. "Heat transfer enhancement in concentric tube heat exchanger in ANSYS FLUENT." International Research Journal Engineering and Technology. (2015) vol.4, Pp. 7-10.
- [6] Holger martin et.al. "Calculation of heat transfer from pressure drop in tube bundles." Edizioni ETS ,Pisa (2000) Pp.
- [7] Milind v. rane et.al. "Water to water heat transfer in tube –tube heat exchanger." Applied Thermal Engineering. (2005) Pp. 2715- 2729.
- [8] Tejal m. rana "Effect of tube diameter on heat transfer through staggered tube bundles of shell and tube heat exchanger." International Journal of Advance Engineering and Research Development. (2017).
- [9] Xu Xiu-qinga,b, , Bai Zhen-quana, Feng Yao-ronga, Ma Qiu-ronga, Zhao Wen-zhen, The influence of temperature on the corrosion resistance of 10 carbon steel for refinery heat exchanger tubes, Applied Surface Science 280 (2013) 641–645.
- [10] Zan Wu, Lei Wang, Bengt Sundén, Pressure drop and convective heat transfer of water and nanofluids in a double-pipe helical heat exchanger, Applied Thermal Engineering 60 (2013) 266e274.
- [11] Dillip Kumar Mohanty , Pravin M. Singru, Fouling analysis of a shell and tube heat exchanger using local linear wavelet neural network, International Journal of Heat and Mass Transfer 77 (2014) 946–955.
- [12] Ji Chan Park, Nam Sun Roh, Dong Hyun Chun, Heon Jung, Jung-II Yang, Cobalt catalyst coated metallic foam and heat-exchanger type reactor for Fischer–Tropsch synthesis, Fuel Processing Technology 119 (2014) 60–66.
- [13] Morteza Khoshvaght-Aliabadi , Ahmad Alizadeh, An experimental study of Cu–water nanofluid flow inside serpentine tubes with variable straight-section lengths, Experimental Thermal and Fluid Science 61 (2015) 1–11.
- [14] Hamed Sadighi Dizaji, Samad Jafarmadar*, Mehran Hashemian, The effect of flow, thermodynamic and geometrical characteristics on exergy loss in shell and coiled tube heat exchangers, Energy 91 (2015) 678e684
- [15] P.V. Durga Prasad¹, A.V.S.S.K.S. Gupta² and K. Deepak, Investigation of Trapezoidal-Cut Twisted Tape Insert in a Double Pipe U-Tube Heat Exchanger using Al₂O₃/Water Nanofluid, Procedia Materials Science 10 (2015) 50 – 63.
- [16] Paisarn Naphon et al., studied the effectiveness of curvature ratio on the heat transfer and flow developments in the horizontally spirally coiled tubes, International communications in Heat and Mass Transfer xxx(2016).

