

Chopper Fed Closed Loop Speed Controller System For Separately Excited Dc Motor For Industrial Application USING PI Controller

¹Avinash Krishna Raikwar,²C.S.Sharma

¹M.E. Scholar,²Associate Professor & HOD of EE Department.

Department of Electrical Engineering ,Samrat Ashok Technological Institute, Vidisha (MP),INDIA

Abstract : The speed of the separately excited DC motor can be controlled from below and above the rated speed by using buck converter. This paper presents the speed control methodology by varying armature voltage of the DC motor. The chopper gives variable voltage to the armature of the motor for achieving desired speed using Proportional Integral (PI) controller. The reason behind using PI controller is it removes the delay and provides fast control. The modeling of separately excited DC motor is done and the complete layout of DC drive mechanism is obtained. The reference signal is compared with triangular carrier signal and to produce the PWM pulses for chopper switch. The simulation model is constructed in the MATLAB/SIMULINK. The simulated output parameters of the DC motor such as; armature current, voltage, speed, torque, and field current are analyzed. The MATLAB simulation will be used to perform the various conditions of loads but here we are taken as a constant load with small disturbance. So the motor speed will be disturbed with small time period and maintained the constant and PI controller having a different gain value.

Keywords: Armature Voltage control, DC/DC Buck converter, Proportional Integral (PI) controller. PWM generator, separately excited DC motor.

1.INTRODUCTION

DC motors have been available for roughly about 100 years. In fact these were the earliest motor to be designed and operated using direct current power. After invention of AC motors they became horse power of industry due to high speed operation, smaller, lighter, less expensive and bear few maintenance comparing to the DC motors but the latter are still used for their various advantages. The reasons for this are that they exhibit good speed regulation, wide speed range, high starting and accelerating torques. They have less complicated control and are less expensive drive. Today, there are still use of DC motors in many applications like textile industries, industrial production and processing of paper pulp, in traction purposes and in electric vehicle (EV) [17]. The power electronics converters, such as controlled rectifier fed (thyristor-fed) DC drives [16], [18] or chopper-fed DC drives are used for their control. Proportional-Integral-Derivative (PID) control is the most common control method used in industry. The popularity of PID controller is due to its robust performance and partly to their simplicity, which allows engineers to operate them in a simple manner. FOPID is a generalized form of ordinary integer order PID with fractional integro-differential operators. FOPID controller provides two extra degree of freedom in the form of orders of integration (α) and differentiation (β) in addition to the conventional controller parameters: Proportional gain (K_p), Integral gain (K_i) and Differential gain (K_d). The extra freedom provide improvement in the overall closed loop performance of any system such as overshoot, settling time, rise time, phase margin etc. Several schemes for the design of FOPID controller, employed in control system are pole distribution, frequency domain approach, state space design method etc. In recent years, few intelligent algorithms such as Genetic Algorithm (GA) [21], Particle Swarm Optimization (PSO) have been explored in literature [22]. The MATLAB simulation will be used to perform the various conditions of loads but here we are taken as a constant load with small disturbance. So the motor speed will be disturbed with small time period and maintained the constant and PI controller having a different gain value.

2.LITERATURE REVIEW

Development of high performance motor drives is very essential for industrial applications. A high performance motor drive system must have good dynamic speed command tracking and load regulating response [1]. DC motors provide excellent control of speed for acceleration and deceleration. The power supply of a DC motor connects directly to the field of the motor which allows for precise voltage control, and is necessary for speed and torque control applications [2]. The buck converter is delivers the best performance of the DC-DC step down converter. The power semiconductor devices used for a chopper circuit can be force commutated thyristor, power BJT, MOSFET, IGBT and GTO based chopper are used. It having very low switching losses that means total voltage drop has 0.5V to 2.5V across them [3]-[6]. DC drives, because of their simplicity, ease of application, reliability and favorable cost have long been a backbone of industrial applications. DC drives are less complex as compared to AC drives system. DC drives are normally less expensive for low horse power ratings. DC motors have a long tradition of being used as adjustable speed machines and a wide range of options have evolved for this purpose. Cooling blowers and inlet air flanges provide cooling air for a wide speed range at constant torque. DC regenerative drives are available for applications requiring continuous regeneration for overhauling loads [7]. AC drives with this capability would be more complex and expensive. Properly applied brush and maintenance of commutator is minimal. DC motors are capable of providing starting and accelerating torques in excess of 400% of rated [8]-[9]. DC motors have long been the primary means of electric traction. They are also used for mobile equipment such as golf carts, quarry and mining applications. DC motors are conveniently portable and well fit to special applications, like industrial equipments and machineries that are not easily run from remote power sources [10]. DC motor is considered a Single Input and Single Output (SISO) system having torque/speed characteristics compatible with most mechanical loads. This makes a DC motor controllable over a wide range of speeds by proper adjustment of the terminal voltage. Now days, Induction motors, Brushless DC motors and Synchronous motors have gained widespread use in electric traction system. Even then, there is a persistent effort towards making them behave like DC motors through innovative design and control techniques. Hence DC motors are always a good option for advanced control algorithm because the theory of DC motor speed control is extendable to other types of motors as well. Speed control techniques in separately excited DC motor are by varying the armature voltage for below the rated speed and by varying field flux should to achieve speed above the rated speed [11]-[13]. Different methods for speed control of DC motor are traditionally armature voltage using rheostatic method for low power DC motors, use of conventional PID controllers, neural network controllers, constant power motor field weakening controller based on load-adaptive multi-input, multi-output linearization technique for high speed regimes, single phase uniform PWM AC-DC buck-boost converter with only one switching DOI: 10.9790/1676-1103016569 www.iosrjournals.org 66 | Page device used for armature voltage control, using NARMA-L2 (Non-linear Auto-Regressive Moving Average) controller for the constant torque region [14]. Large experiences have been gained in designing trajectory controllers based on self-tuning and PI control. The PI based speed control has many advantages like fast control, low cost and simplified structure. This paper mainly deals with controlling DC motor speed using Chopper as power converter and PI as speed and current controller [10]. Here applying pulse width modulation (PWM) signals to the converter with respect to the motor input voltage it is one of the methods most employed to drive a DC motor. However, the underlying hard switching strategy causes an unsatisfactory dynamic behavior, producing abrupt variations in the voltage and current of the motor [15].

3.CHOPPER

A dc chopper is a static switch to provide variable dc voltage from a source of constant dc voltage. Choppers are now being used all over the world for rapid transit systems. These are also employed in trolley cars, marine hoists, forklift trucks and mine haulers. The future electric automobiles are likely to use choppers for their speed control and braking. Chopper systems offer smooth control, high efficiency, fast response and regeneration.

3.1 Principle of Operation of Chopper:

A dc chopper is a high speed on/off semiconductor switch that connects the load to and disconnects it from the supply and produces a chopped load voltage from a constant input supply voltage. As it is an on/off switch between source and load, it can be symbolically represented by a switch S inside a dotted rectangle, as shown in Fig. 1. Actually, a chopper consists of main power

semiconductor device together with their turn-on and turn-off mechanisms. In low-power chopper circuits, power transistors, GTOs etc. are used widely. In high-power chopper circuits, however, thyristors are in common use.

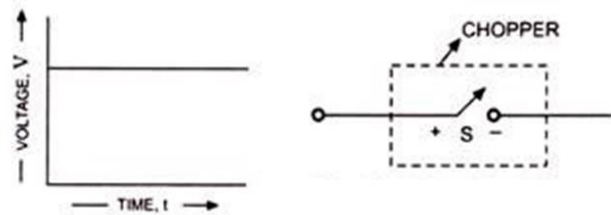

figure1:- simple chopper block

Figure 2 illustrates the principle of operation of a chopper. The switch may be closed or opened by supplying on/off pulses to it. Here the mechanism of sending pulses to a switch has not been shown. A shunting diode D_{FW} is provided across the load for freewheeling the load current when the switch S is off. When the switch S is closed, the source voltage V, assuming that voltage drop across switch S in on-state is negligible, appears across the load for the duration the switch is closed.

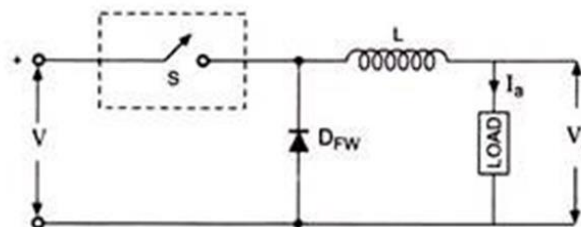

figure2:- Elementary chopper circuit

This duration is designated T_{on} . After the pulse to switch is removed the load is disconnected from the source. The energy stored in the inductor circulates a current through the freewheeling diode D_{FW} . As a result the load is short circuited and voltage across it falls to zero but the current through the load falls exponentially, as illustrated in Fig. 3. The duration for which switch is off is called off time T_{off} . The total time of a pulse is, therefore, given by $T = T_{on} + T_{off}$.

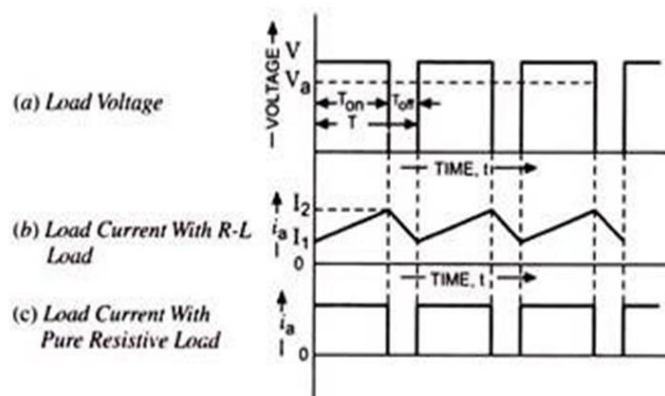

figure3 : voltage and current waveforms

Thus, a dc chopped voltage is produced at the load terminals [Fig. 3 (a)] and the load current is continuous as shown in Figs. 3. (b) and (c). From Fig. 3(a), the average load voltage V_a is given by-

$$V_a = V \frac{T_{on}}{T_{on} + T_{off}} = V \frac{T_{on}}{T} = \alpha V \quad \dots 3.1$$

where $\alpha = T_{on}/T$ is called duty cycle of the circuit. It is analogous to transformation ratio of ac transformer. The value α of ranges from 0 to 1. Hence the output voltage varies between zero and supply voltage V. In the present case the output voltage is less than the supply voltage. It is, therefore, called step-down chopper. In choppers, called step-up choppers, the output voltage is more than supply voltage. The load current and voltage waveforms, as shown in Figs. 3 (b) and (a) are for R-L load. However, in case,

resistive load is used in the output, the current and voltage waveforms have similar variations as illustrated in Fig. 3. (c) and (a). In case of R-L load, the inductor absorbs energy from the source during on-period while same is released by it during off- period. We can write, by using conservation of energy principle;

Energy absorbed = Energy released

$$\begin{aligned} \text{or } VI &= V_a I_a \\ \text{or } I &= \frac{V_a}{V} I_a = \alpha I_a \\ \text{or } \frac{I}{I_a} &= \alpha = \frac{V_a}{V} \end{aligned}$$

..... 3.2

Above relation is similar to that for an ac transformer. Here α , the duty cycle, corresponds to transformation ratio of transformer. The output of a chopper, as can be observed from Eqs. (3.1) and (3.2), can be controlled by a variation in α , the duty cycle.

3.2 Control Strategies:

It is seen from Eq. (3.1), that, average value of output voltage, V can be controlled by periodic opening and closing of the semiconductor switch. There are two types of control strategies for operating the switches that can be used in dc choppers. These control strategies are time-ratio control (TRC) and current limit control.

3.2.1. Time-Ratio Control:

In this control strategy, the value T_{on}/T of is varied. This is affected in two ways namely variable frequency control and constant frequency control.

(a) Variable Frequency Control (FM):

Under such scheme the chopping frequency f is kept variable and for this purpose either (a) on time, T_{on} or (b) off time, T_{off} is kept constant. This scheme is, therefore, called frequency modulation scheme and is illustrated in Fig. 4 In Fig. 4 (a) and (b) on time T_{on} is kept constant while off time T_{off} of the switch is variable. The duty cycles in two figures are $\alpha_1 = T_{on}/T_{on} + T_{off} = 3/4$ and $\alpha_2 = 1/2$ respectively. Figure 4 (c) and (d) are for variable on time T_{on} and constant off time T_{off} . The duty cycle in the two cases are respectively $1/4$ and $2/5$. This technique is suitable for switches which require forced commutation to turn off.

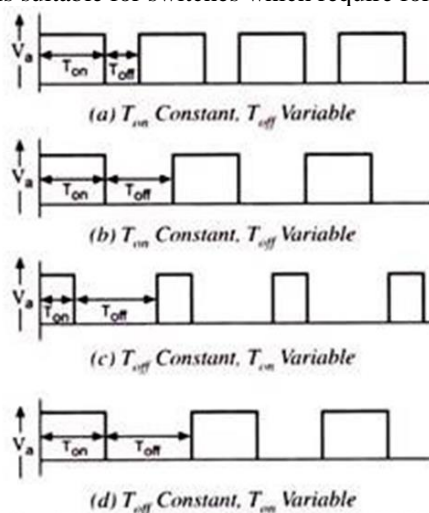

figure 4. output voltage waveform for variable frequency control

(b) Constant Frequency Control:

Under this control scheme the chopping period T remains constant but the pulse width T is varied to control the output. This is, therefore, called pulse width modulation (PWM) control. The scheme is illustrated in Fig. 5. In the figure, time $T = T_{on} + T_{off}$ is constant but T_{on} and T_{off} both are variable. The duty cycles of $\alpha = 0.75$ and 0.50 are shown, respectively, in Figs. 5 (a) and (b).

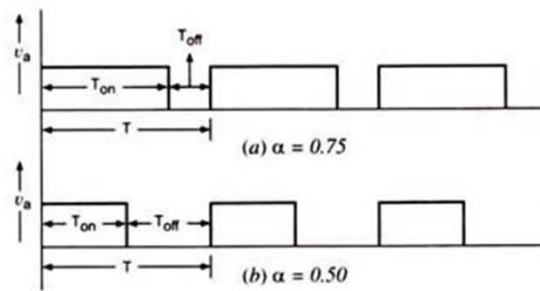

figure5:- constant frequency control

3.2.2 Current Limit Control

Under this scheme the chopper is switched on and off between upper and lower limits of load current. As the load current exceeds upper limit the chopper is turned off. The load current now freewheels until it reaches the lower value prescribed. As the load current attains lower limit, the chopper is switched on. As the freewheeling operation is involved in this scheme, a storage element is a necessity in the load. As the load current varies between two prescribed limits, this scheme is applicable only either at constant frequency or at constant turn on time T_{on} . The waveforms for current limit control are shown in Fig. 6. In this case the load current is continuous and difference between upper and lower values of current decides the switching frequency. At smaller values of difference in current, the switching frequency is higher. As a result the ripples in the output are reduced. As an example the switching frequencies of the chopper for $I_{a \max}$ and $I'_{a \max}$ as upper limits of the current are, respectively $1/T'$ and $1/T$ where $I'_{a \max} < I_{a \max}$ and $T' < T$. By further reducing the difference between upper and lower limits of the current the switching frequency can be increased correspondingly which leads to reduction in the ripple content in the output.

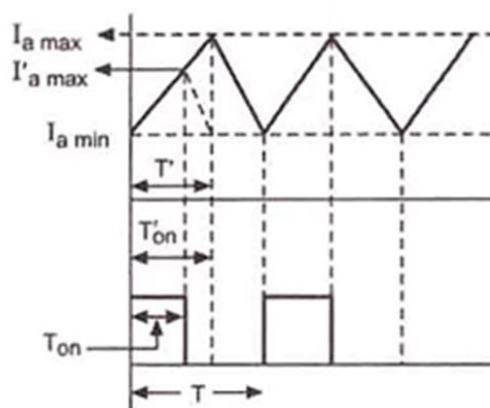

figure6 :- current limit control

4. Dc/Dc Buck Converter

Buck converter is a DC-DC power converter shown in Fig.7. It steps down voltage from its input supply to its output load. It consists of DC input voltage source V_{in} , controlled switch S , diode D , filter inductor L , filter capacitor C , and load resistance R . The typical voltage and current waveform of buck converter are shown in Fig.8. Under the assumption the inductor current is always positive. It can be seen from the circuit that when the switch S is commanded to the ON state, the diode D is reverse-biased. When the switch S is OFF, the diode conducts to support an uninterrupted current in the inductor .

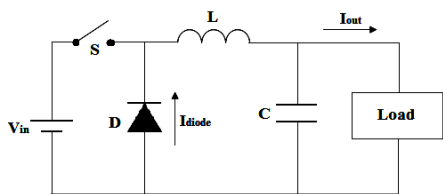

Fig.7. Buck converter

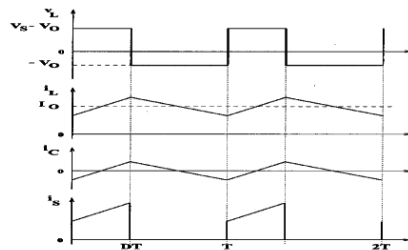

Fig.8. Voltage and current waveform

Fig.8 shows the relationship among the input voltage and output voltage, inductor current I_L , capacitor current I_C , and the switch duty ratio D can be derived, for instance, from the inductor voltage V_L . According to Faraday’s law, the inductor volt-second product over a period of steady-state operation is zero. For the buck converter, the DC voltage transfer function, defined as the ratio of the output voltage to the input voltage, is $V_o/V_s=D$ (1) It can be seen from that equation the output voltage is always smaller than that the input voltage. The converter maintains the constant output voltage.

5. Separately Excited Dc Motor

Fig.9. shows the equivalent circuit of the separately excited DC motor. The separately excited DC motor has armature and field winding with separate supply. The field windings of the DC motor are used to excite the field flux. Current in armature circuit is supplied to the rotor via brush and commutator segment for the mechanical work. The rotor torque is produced by interaction of field flux and armature current.

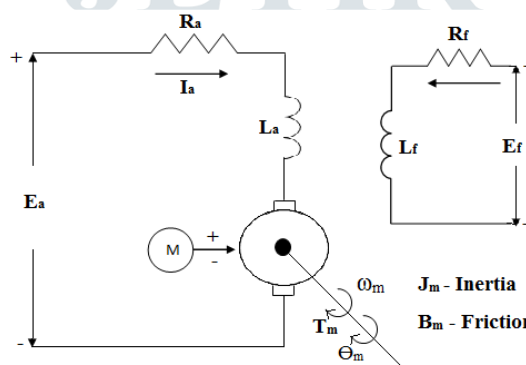

Fig.9. Equivalent circuit of separately excited DC motor

When a separately excited DC motor is excited by a field current of i_f and an armature current of i_a flows in the circuit, the motor develops a back EMF and a torque to balance the load torque at a particular speed. The field current i_f is independent of the armature current i_a . Each winding is supplied separately. Any change in the armature current has no effect on the field current. The i_f is generally much less than the i_a .

6. CONTROLLERS

Controller is a device which monitors and alters the operating conditions of a given dynamical system. The control algorithms are usually divided into two main types: Open-loop and Closed-loop.

6.1 Open loop control system

An open-loop system is a type of control system in where system output depends on input but input or the controller is independent of the output of the system. These systems do not reside in any response loop and are therefore known as Non-Feedback System. We know that a control system directs the operation of a system for specified purpose. Everything around us that offer output requires proper control such as fan,TV, refrigerator to satellites etc. everything needs to be controlled, so control systems. In an open loop control system, a reference input is provided to the system to get the appropriated output. however the extracted output is not processed by the system for opposite reference input. The figure 10 here represents the block diagram of an open-loop control system:

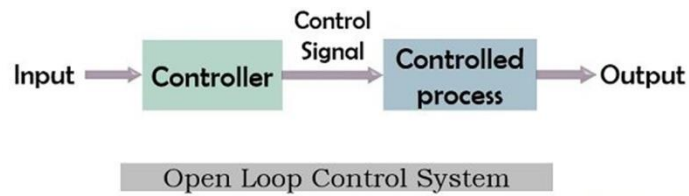

Figure10:- Block diagram of an open-loop control system:

Here as we can see that the system consists of two blocks, one is the controller while other is controlled process. Basically, according to the required output, an input is provided to the controller of the system. Depending on the achieved input, the controller generates the control signal which is fed to the processing unit. Thus according to the control signal, proper processing is performed and output is achieved.

Advantages :

- Simple in construction and design.
- Economical uses.
- Easy to use as result difficult to measure.

6.2 Closed Loop System

A closed-loop control system is a type of control system in which the controlling action shows dependency on the generated output of system. In simple language, in these systems, the system output controls the input applied to the system. The variation of input by the output leads to produce more accurate system output. Thus controllability in the closed-loop system is achieved through the output generated by utilizing a feedback path. closed-loop systems are considered as fully automatic control system because it is designed in a way that the achieved output is automatically compared with the reference input to have the required output

Operation of a Closed Loop System :

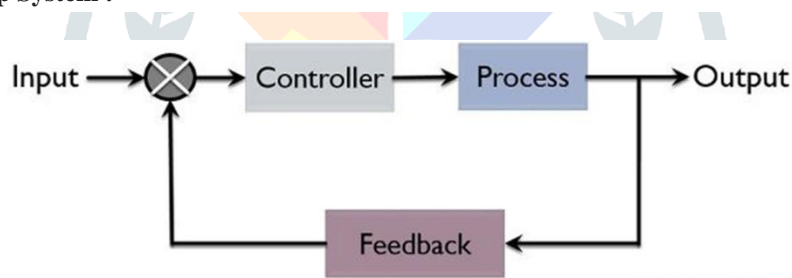

figure11. Block diagram pictorial of a closed-loop control system

The figure11. shows the detailed block diagram pictorial of a closed-loop control system :this is because it is not always necessary for the input available to be accepted by controller. Therefore in such a case, the input cannot be requested directly from the system. As it has to be changed from one form to another in order to be perform the role of reference input. This is the reason input is beginning applied to the transducer to be changed into an acceptable form with a system apt to the suitable controller and process. When controller generates the control signal due to input applied, then the required action according to the created signal takes place inside the system This guides to the generation of a specific output. except it is necessary to measure the prompted output in order to find whether it is the desired output or not. therefore, a part of the achieved output is given back to the input. This signal behave like a feedback signal. This feedback signal, when compared with credential input, produces an error signal. This error signal is further provided to the controller that produces a manipulated signal (proportional to error signal) is nothing but a control signal that navigates the process to eliminate the error thereby producing the desired output.

Advantages :

- precision : they are more accurate than an open loop system due to their complex construction. They are equally accurate and are not disturbed when something is non-linearities.
- Ability to reduce noise : they are composed of a feedback mechanism, thus erasing the errors between input and output signals, so they remain unaffected by external noise source.

6.3 PI controllers

The PI controllers are widely used in industrial practice for more than 60 years. The development went the pneumatic through analogue to digital controllers, but the control algorithm is in fact the same. The PI controller is standard and proved solution for the most industrial application. The PI algorithm computes and transmits a controller output signal every sample time (T), to the final control element. PI controllers have two tuning parameters to adjust and the parameters are current I and torque T. PI controller will not increase the speed of response, so it maintain the constant speed of the DC motor. PI controller is mainly used to eliminate the steady state error resulting from P controller. However, in terms of the speed of the response and overall stability of the system, it has a negative impact. This controller is mostly used in areas where speed of the system is not an issue. Since PI controller has no ability to predict the future errors of the system it cannot decrease the rise time and eliminate the oscillations. If applied, any amount of I guarantees set point overshoot. PI controllers are very often used in industry, especially when speed of the response is not an issue. The PI controller for the current loop using bode analysis or other control system design tools. The next step is usually the design of the speed controller. The 0-db intercept of $1/J_s(1+Tis)$ is normally much too low. The main reason is its relatively simple structure, which can be easily understood and implemented in practice, and that many sophisticated control strategies, such as model predictive control, are based on it. An application with large speed capabilities requires different PI gains than an application which operates at a fixed speed. In addition, industrial equipment that are operating over wide range of speeds, requires different gains at the lower and higher end of the speed range in order to avoid overshoots and oscillations. Generally, tuning the proportional and integral constants for a large speed control process is costly and time consuming. The task is further complicated when incorrect PI constants are sometimes entered due the lack of understanding of the process. The control action of a proportional plus integral controller is defined as by following equation:

$$u(t) = K_p + K_i \int e(t) dt \quad (2)$$

Where: $u(t)$ is actuating signal. $e(t)$ is error signal. K_p is Proportional gain constant. K_i is Integral gain constant. The Laplace transform of the actuating signal incorporating in proportional plus integral control is

$$U(s) = K_p + K_i \int E(s) ds \quad (3)$$

The block diagram of closed loop control system with PI control of DC motor system is shown in Fig.12 The error signal $E(s)$ is fed into two controllers, i.e. Proportional block and Integral block, called PI controller. The output of PI controller, $U(s)$, is fed to DC Motor system. The overall output of DC drive, may be speed or position, $C(s)$ is feedback to reference input $R(s)$. Error signal can be remove by increasing the value of K_p , K_i .

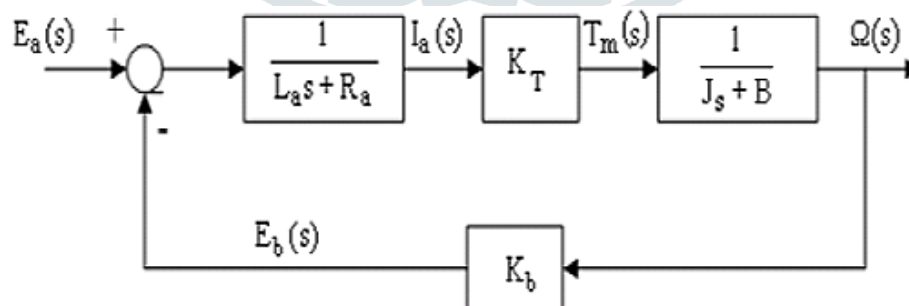

Fig.12 Closed loop control of DC motor

7. Mat lab Simulation

The MATLAB simulation model is shown in Fig.13. In that model the IGBT is used as a switch for the best performance of speed control, fast switching and low losses. Here 5HP, 240V, 1750 rpm separately excited DC motor and additionally 240V DC supply are given to the field. To take the constant load of the circuit consider its load 2 Kg/n at constantly. In that simulation, there are four motor parameters are monitored by using displays, such as armature voltage, armature current, torque and speed of the DC Motor.

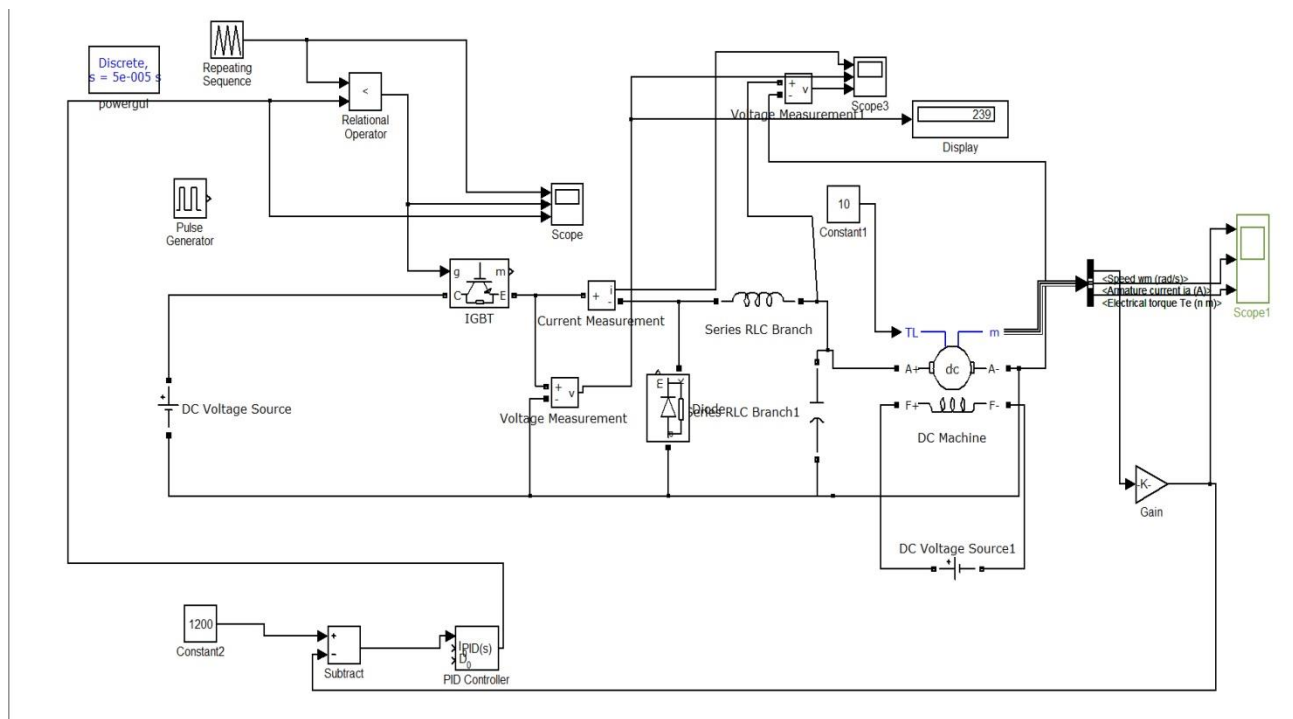
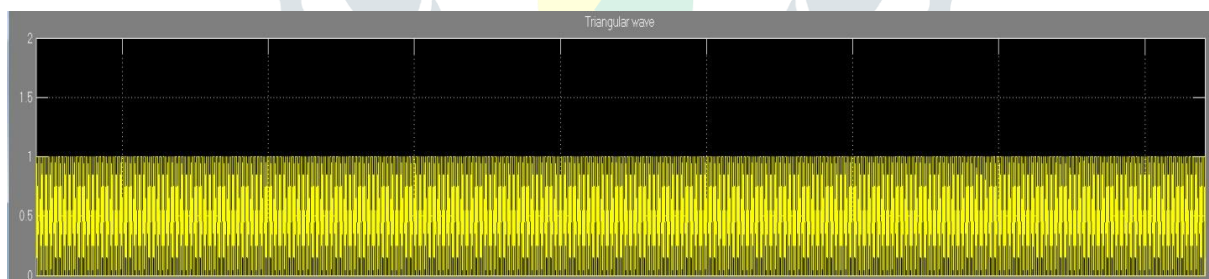

figure 13:- Simulation model of separately excited DC Motor.

Here the freewheeling diode is to maintain continuous current path in the armature. The discrete PI controller gain is chosen by the trial and error method. In that PI controller output is act as the modulation index of the converter. The relational operator can be comparing the reference signal to the carrier signal. To set the maximum reference value of PI controller output is 1V. When the carrier signal voltage is more than reference voltage that time IGBT go to OFF or 0 state. Otherwise the IGBT maintain the ON or 1 state. The Fig.14shows the PWM Pulse generation for the converter. This paper successfully done the simulation for the chopper fed speed control of separately excited DC motor using PI controller. The outputs of the simulation results are shows in figure15.



(a) Triangular carrier



(b) PWM Pulses

Fig.14.Pulse generation. (a)Triangular carrier and. reference signal and (b) PWM Pulses.

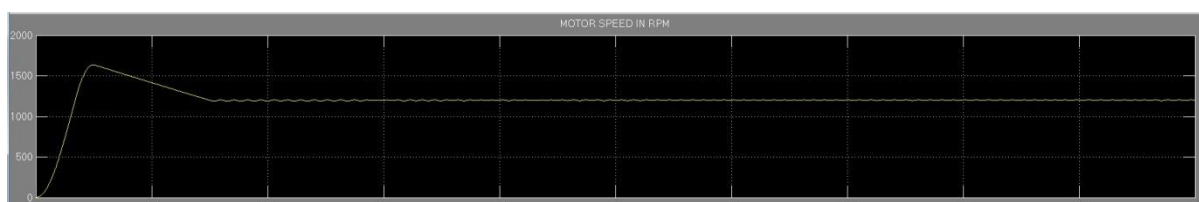

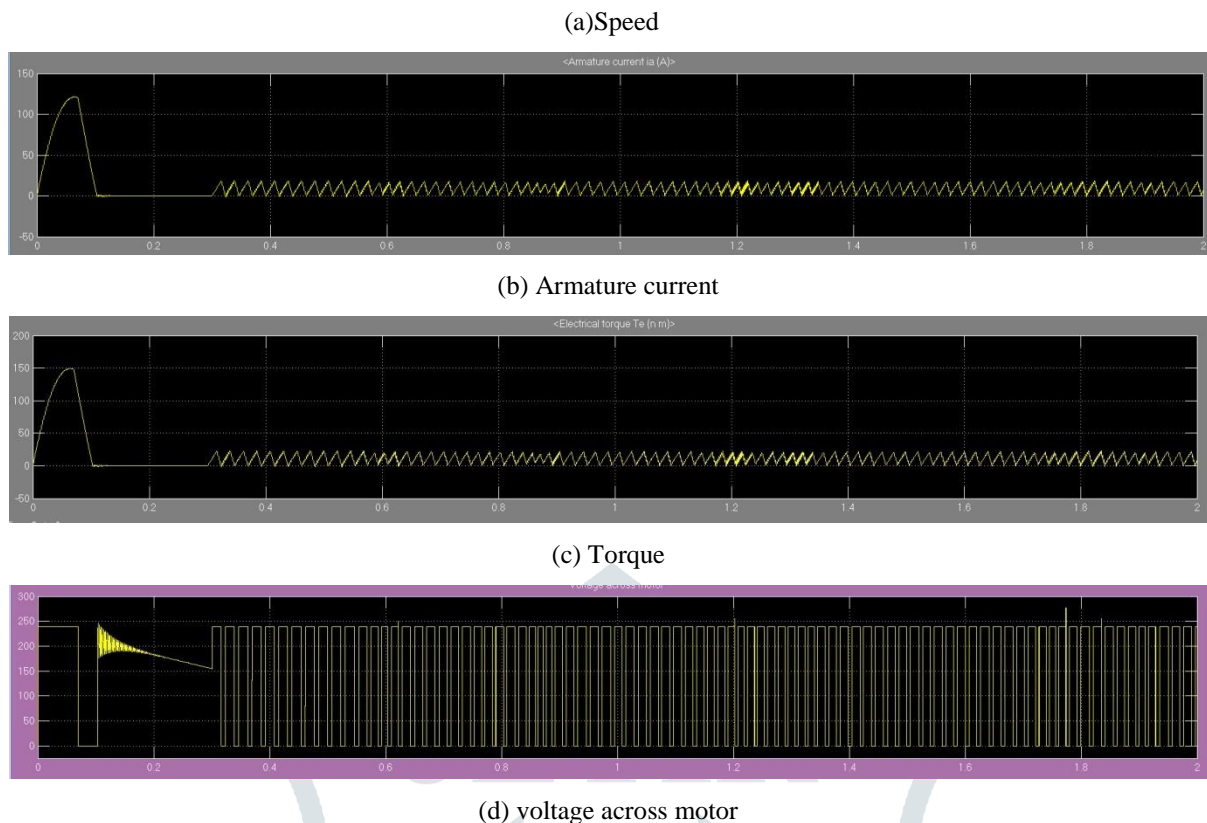

Fig.15. Simulation output of D.C motor. (a)Speed, (b) Armature current, (c) Torque and (d) voltage across motor

8. Conclusion

The speed of a DC motor has been successfully controlled by using Chopper as a converter and Proportional Integral as the controller for closed loop speed control system. Initially a simplified closed loop model for speed control of DC motor is considered and requirement of PI controller is studied. Then a generalized modeling of separately excited DC motor is done. The MATLAB/SIMULINK model shows good results under below the rated speed during simulation. The simulation output creates the constant armature voltage and constant field current that time speed and torque of DC motor also produced constant output. Here using buck converters the switching losses will be reduced and motor efficiency are reach approximately more than 95%.

Reference

- [1] Amir Faizy, Shailendra Kumar, DC motor control using chopper, NIT Rourkela 2011.
- [2] Ramon Silva-Ortigoza, Victor Manuel Hernandez-Guzmán, Mayra Antonio-Cruz, and Daniel Muñoz-Carrillo DC/DC Buck Power Converter as a Smooth Starter for a DC Motor Based on a Hierarchical Control IEEE transactions on power electronics, vol. 30, no. 2, february 2015.
- [3] M. H. Rashid, Power Electronics: Circuits, Devices and Applications (3rd Edition), Prentice Hall, 2003.
- [4] Z. Chen, W. Gao, J. Hu, and X. Ye, "Closed-loop analysis and cascade control of a non minimum phase Boost converter," IEEE Trans. Power Electronics., vol. 26, no. 4, pp. 1237–1252, Apr. 2011.
- [5] H. Sira-Ramírez and M.A.Oliver-Salazar, "On the robust control of Buck converter DC-motor combinations," IEEE Trans. Power Electron., vol. 28, no. 8, pp. 3912–3922, Aug. 2013.
- [6] J. Linares-Flores and H. Sira-Ramírez, "DC motor velocity control through a DC-to-DC power converter," in Proc. IEEE 43rd Conf. Decision Control, Atlantis, The Bahamas, Dec. 14–17, 2004, vol. 5, pp. 5297-5302.
- [7] Moleykutty George., Speed Control of Separately Excited DC motor, American Journal of Applied Sciences, 5(3), 227-233, 2008.
- [8] Dubey, G.K., Fundamentals of Electrical Drives. New Delhi, Narosa Publishing House, 2009.
- [9] S E. Lyshevski, Electromechanical Systems, Electric Machines, and Applied Mechatronics. Boca Raton, FL, USA: CRC Press, 1999.

- [10] Badal kumar sethy , Abhishek kumar sinha DC motor control using chopper, NIT Rourkela 2013.
- [11] J. Linares-Flores, H. Sira-Ramírez, J. Reger, and R. Silva-Ortigoza, “An exact tracking error dynamics passive output feedback controller for a Buck-Boost-converter driven DC motor,” in Proc. 10th IEEE Int. Power Electronics. Conger., Cholula, Puebla, Mexico, Oct. 2006, pp. 1–5.
- [12] J. Linares-Flores, H. Sira-Ramírez, E. F. Cuevas-López, and M. A. Contreras-Ordaz, “Sensorless passivity based control of a DC motor via a solar powered Sepic converter-full bridge combination,” J. Power Electron., vol. 11, no. 5, pp. 743–750, Sep. 2011.
- [13] ZHANG Li, QIU Shui-sheng, “Analysis and Experimental study of Proportional- Integral sliding mode control for dc/dc converter,” Journal of Electronic Science and Technology of China, vol. 3, no. 2, pp. 140-143, Jun. 2005.
- [14] F. Anritter, P. Maurer, and J. Reger, “Flatness based control of a buck converter driven DC motor,” in Proc. 4th IFAC Symp. Mechatron. Syst., Heidelberg, Germany, Sep. 12–14, 2006, pp. 36–41.
- [15] L. Iannelli and F. Vasca, “Dithering for sliding mode control of DC/DC converters,” in Proc. IEEE PESC Rec., vol. 2, pp. 1616–1620, Jun. 2004.
- [16] B. H. Khan, G. K. Dubey, S. R. Doradla, “Four Quadrant AC-DC GTO Converter-Fed DC Motor Drive”, Electric Machines and Power Systems, 28:885–892, 2000
- [17] G. Uma, C. Chellamuthu, “A Novel Closed Loop Operated Soft Switched DC To DC Converter Fed DC Motor for Electric Vehicles”, 2000 IEEE
- [18] B. H. Khan, G. K. Dubey, S. R. Doradla, “A Three-phase AC-DC GTO Thyristor Converter Employing Equal Pulse-Width Modulation”, IEEE Transactions On Industry Applications, Vol. 27, No. 2, March/April 1991.
- [19] Ainee Ansaari, Hardik Mehta, “Four Quadrant Operation of Chopper – Fed Separately Excited DC Motor by Decoupled PWM Control Using Digital Signal Processor”, International Journal of Science, Engineering and Technology Research (IJSETR), Volume 4, Issue 5, May 2015
- [20] Livinti Petru , Ghandour Mazen, “PWM Control of a DC Motor Used to Drive a Conveyor Belt”, 25th DAAAM International Symposium on Intelligent Manufacturing and Automation, DAAAM 2014.
- [21] P. Wang, D. P. Kwok. Optimal design of PID process controllers based on genetic algorithms,. Control Engineering Practice, Vol. 2(4), pp. 641- 648, 1994.
- [22] <http://ctms.engin.umich.edu/>
- [23] Z. Gaing, “A particle swarm optimization approach for optimum design of PID controller in AVR system”, IEEE Trans. Ener. Conve, vol. 19,no. 2, pp.384-391, June 2004.