

# Smart Substation Automation System using IOT

<sup>1</sup>Suma Gurulingaiah Charantimath, <sup>2</sup>Pavan Kumar.K, <sup>3</sup>Ravitej.M, <sup>4</sup>Vijay Kumar, <sup>5</sup>B Vishwanath

<sup>1</sup>Assistant professor, <sup>2,3,4,5</sup>Students, Electrical and Electronics Department,

PDIT College, Hospet,

Karnataka, India.

## ABSTRACT

A low cost automation solutions based on recent IOT technology and GSM using embedded processors like ARDUINO UNO for automation of a small substation. This gives the advantage of cost reduction plus a plethora of connectivity options. In this paper, arduino IDE software is used to control a feeder with help of GSM module. Analog and digital parameters from field are monitored and controlled using analog pins, interfacing relays and communication ports available in arduino Uno controller. The automation sequences for control monitoring and protection of the system is defined using c program in such a way that it sends the input parameters in the field side to the registered mobile number. The controls of relays and buzzers are based on the control signals that are sent from the operators. If the current exceeds their limits, the microcontroller will automatically trips the circuit breakers and sends that information to the user through IOT uses esp8266 module.

Keywords: IOT, GSM, ARDUINO UNO, Relays.

## INTRODUCTION

Supplying electricity to consumers necessitates power generation, transmission, and distribution. Initially electric power is generated by using electric generators such as: nuclear power generators, thermal power generators and hydraulic power generators and then transmitted through transmission systems using high voltage. Power departs from the generator and enters into a transmission substation, where huge transformers convert the generator's voltage to extremely high voltages (155kV to 765 kV) for long-distance transmission. Automation of substations parameters are the important task for supplying healthy power to the consumers in this automated world but due to the aging infrastructure of the distribution grids (substations) and lack of automation systems that monitors the critical conditions at the substations, the risk of blackouts, brownouts and fire are rapidly increasing. Substations consist of different electronic components like transformers, circuit breakers, relays etc. The transformer fluid leaks or internal insulation breakdown cause overheating that leads to failures. The traditional method includes periodic manual checking of the system which is time consuming and with very low accuracy. Also the substations in the rural areas are even more difficult to monitor manually and hence requires more time to take respective actions. The solution to all these problems is automation of the substations. The various

parameters like current, temperature and voltage are continuously sensed with the help of different sensors. The output signals from sensors are given to Analog to Digital Converter (ADC) and then to the microcontroller. Microcontroller is preprogrammed in such a way that if the parameters exceed predefined threshold value then it will inform the intermediate or main station with the help of wireless communication technologies like BLUETOOTH, GSM etc.

## OBJECTIVE

The objective is to automate the electrical parameters continuously and hence to guard the burning of distribution transformer due to the constraints such as overload, over temperature and input high voltage. The Mini-Substation Automation System will be comprised of a functioning substation protection relay, wireless communications, a data collection and monitoring device, a graphical user interface, and a fault recognition and notification system. Parameters like Voltage, Current, Phase angle and Frequency are monitored. In this project only voltage of power station/substation is automated and sends these real time values over IOT server.

The major building blocks of this project are:

1. Microcontroller based mother board with regulated power supply.
2. Sensors for Voltage, Current, Frequency and Temperature.
3. A relay to control the circuit breaker.
4. LCD display for displaying the electrical parameters and circuit breaker status.
5. Buzzer.

## PROBLEM STATEMENT

The conventional method uses GSM. Since IOT is cost effective compared to SMS, monitoring of energy usage at lower cost is made possible. The system is more reliable and accurate reading values are collected from energy using devices. Live readings of devices can be viewed using Android application. Also, the readings can be viewed online. The human interference is avoided and all the values are kept maintained in the central server. Maintenance is poor compared to proposed system.

### III.PROPOSED METHOD

a.Introduction The main process of a transmission system is to transfer electric power from electric generators to customer area, whereas a distribution system provides an ultimate link between high voltage transmission systems and consumer services. In other words, the power is distributed to different customers from the distribution system through feeders, distributors and service mains. Supplying electricity to consumers necessitates power generation, transmission, and distribution. Nuclear power generators, thermal power generators and hydraulic power generators used to generate the power and then transmitted through transmission systems medium. Power departs from the generator and enters into a transmission substation, where huge transformers convert the generator's voltage to extremely high voltages (155kV to 765 kV) for long-distance (up to about 300 miles) transmission. Voltage level is reduced using step down transformers and power is transferred to customers for their usage through

electric power distribution systems. Power starts from the transmission grid at distribution substations where the voltage is stepped-down (typically to less than 10kV) and carried by smaller distribution lines to supply commercial, residential, and industrial users. The Internet of things (IOT) concept enables us to connect the normal day to day devices with each other over the internet. The devices connected through IOT concept can be analyzed remotely. The IOT concept provides the basic infrastructure and opportunities to form a connection between the physical world and computer based systems. The concept has been gaining importance with more and more wireless devices that are increasing rapidly in the market. Hardware devices are connected with each other over the internet. The ESP 8266 Wi-Fi module used in the system provides the connectivity with the internet in the system.

Now-a-days the demand for electricity is increasing at a constant rate in the population and is being utilized for various purposes via, agriculture, industries, household purposes, hospitals etc.,. So, it is becoming more and more complicated to handle the electricity maintenance and requirements. Therefore there is an immediate requirement to save as much electricity as possible. As the demand from the newer generations of population for electricity is increasing so in along with it the technology improvement is needed. The proposed system uses the IOT technology. Also there are other issues that we have to address such as power theft which in turn generate economic loss to the nation. Monitoring, Optimized power usage and reduction of power wastage are the major objectives that lie ahead for a better system. Smart Sub Station energy meter using Wi-Fi system is designed based on three major objectives. They are:- 1. To provide automated load energy reading over an immediate basis. 2. Reduce the power wastage. 3. To improve quality of power. 4. Remote sensing to Maintain Continuity of supply 5. Real time monitoring. The data from the system is displayed on a webpage which can be accessed by the EB service provider. The system is designed on an Arduino micro controller. The 3 divisions of the project is Controller, theft detection circuit and a WiFi unit. The controller performs the basic calculations and processes the information. Theft detection circuit provides information about any extra or theft load energy reading and the most important role is played by the Wi-Fi unit to send the information from the controller over the Internet. The Arduino controller is programmed on the Arduino software IDE (Integrated Development Environment) which is a prerequisite to operate on the Arduino board. Its code is derivative of the C language

### Block Diagram:

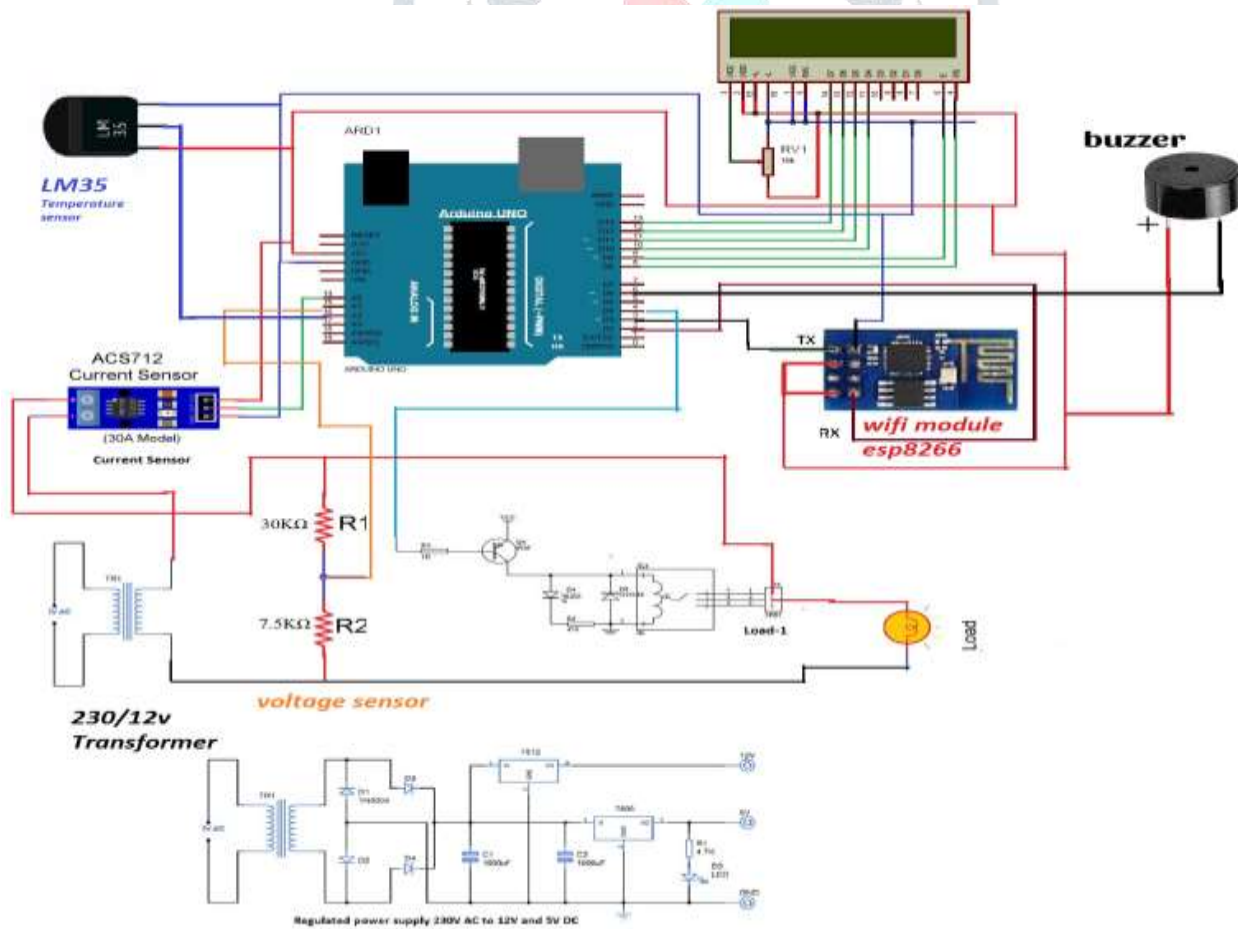
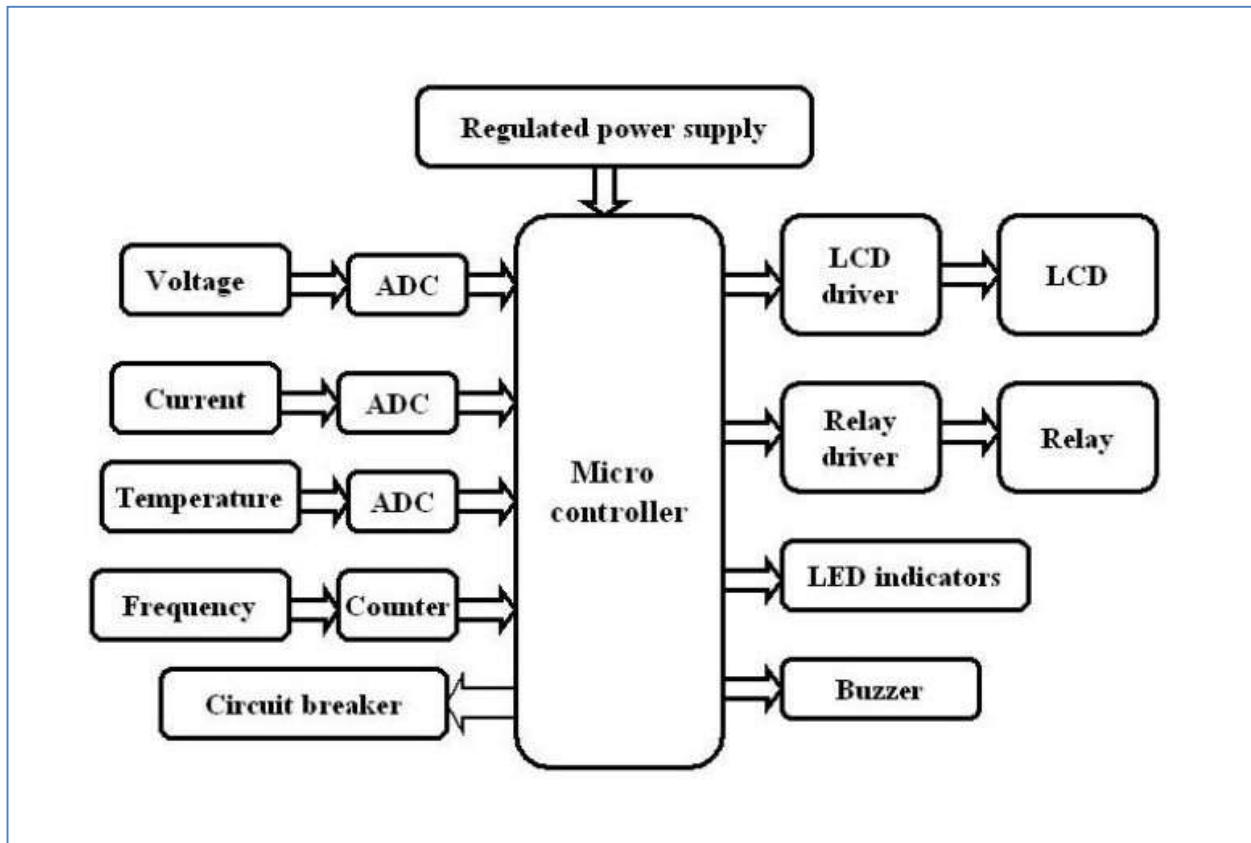

## WORKING PRINCIPLE

The proposed work is designed for fully automatic manner with use of IOT. Here the output side we can take a parameter of feeder information and breaker circuit. For information gathering and controlling process voltage, current and frequency data are collected to the ArduinoUno controller and it compare the value feed in that controller. If the changes in value are displayed by IOT and sending SMS as to GSM. In addition the feeder information also sends to GSM and we can control that operation through GSM command with use of AT command.

If any feeder and breaker fault occur the controller automatically send SMS to user or operator. From this we can controlled easy without any network interferences. All the process takes over by android mobile no need of PC problem. From this we can achieve the automation of substation feeder and breaker circuit. All the status of our project is displayed by using LCD display. The typical ThingSpeak workflow lets you: 1. Create a Channel and collect data 2. Analyze and visualize the data. System can be used to display load energy usage reading in terms of Watts.

Every user would be able to access the information from anywhere on the earth. Thingspeak.com is one such webpage which takes the help of the MathWorks MATLAB analytics to present the device information in a more detailed analysis in both description and visualization. Thingspeak.com provides the user the ability to add any number of channels to one account and in each account information can be fed into 8 fields. An account can be assigned to one division of an area and n channels can be created to a suite of n meters in the locality.

The analytics can be viewed by both the consumer and service provider. Since IOT is cost effective compared to SMS, monitoring of energy usage at lower cost is made possible. Live readings of devices can be viewed using Android application. Also, the readings can be viewed online.

The human interference is avoided and all the values are kept maintained in the central server. The communication medium is secure and tampering of energy meters or theft of electricity can be identified easily. If an error occurs in the system, the value in the central server will not be updated.

## Flow Chart:

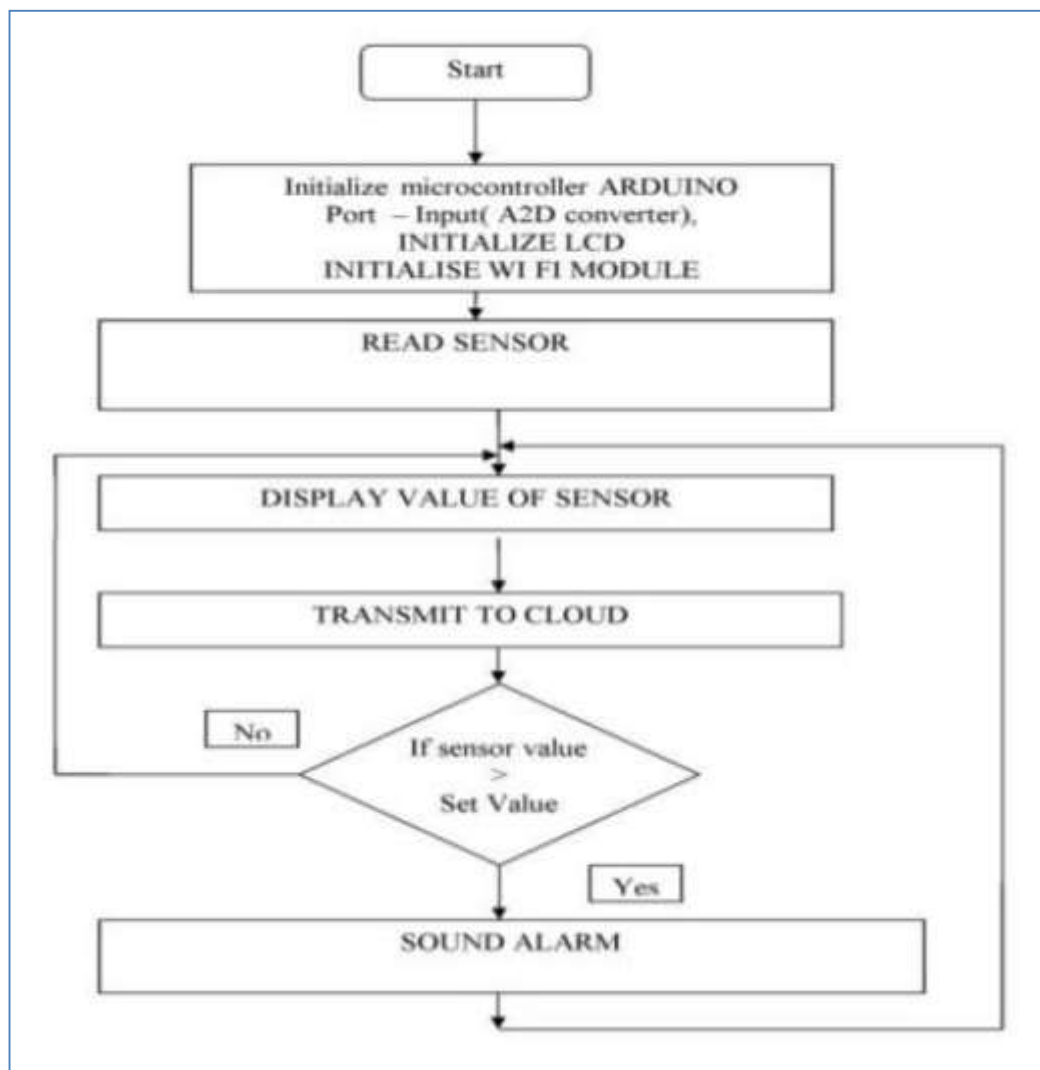

## RESULTS AND DISCUSSION:

The project “Smart Substation using IOT” was designed such that the devices can be monitored using IOT module. All the read values from sensor is graphically noted using IOT in the below image. Thus the proposed concept has been successfully implemented and tested in hardware and software.

### IOT Server Results:



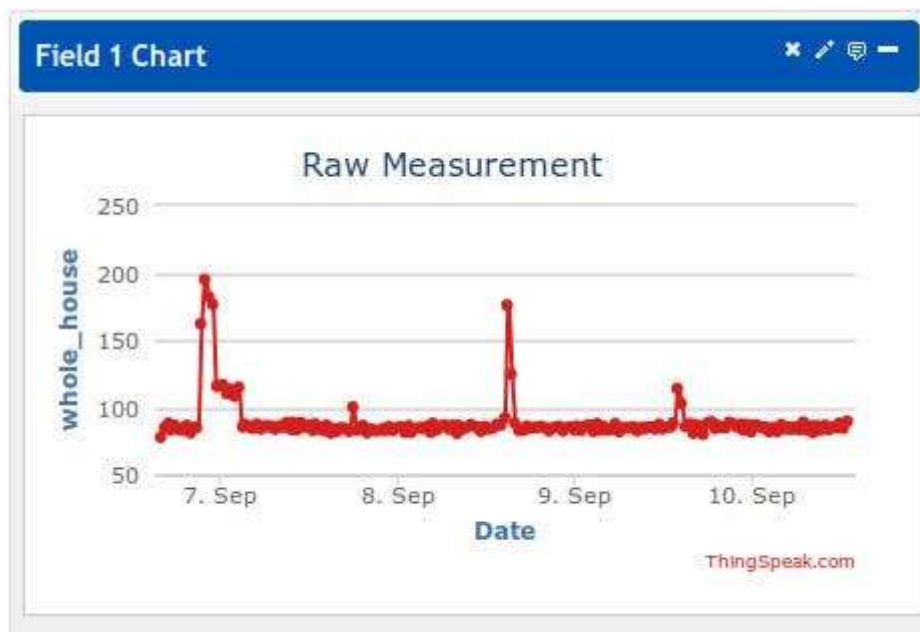

## CONCLUSION:

On completion of our project “Smart Substation” we can improve the quality of power transferred and provide uninterrupted power supply. Sub-station Automation using IOT is an innovative application of internet of things developed to control home appliances remotely over the cloud from anywhere in the world. In the proposed project current sensor is used to sense the current and display it on internet using IOT is achieved. The system updates the information in every 1 to 2 seconds on the internet using public cloud THINGSPEAK. In the present system, energy load consumption is accessed using Wi-Fi and it will help consumers to avoid unwanted use of electricity. Automation controlled by user command is done using esp8266 wifi module. Thus the project is successfully implemented in both Hardware and simulation.

## REFERENCES:

- [1] Amit Sachan “gsm based Automated Embedded System for Monitoring and Controlling of Smart grid” International Journal of Electrical, Computer, Energetic, Electronic and Communication Engineering Vol:7, No:12, 2013.
- [2] Gubbi, J., Buyya, R., Marusic, S., & Palaniswami, M, " Internet of Things (IoT): A vision, architectural elements, and future directions", Future Generation Computer Systems Journal, Volume 29, Issue 7, ELSEVIER, pp.1645-1660,2013
- [3] M. Frankowiak, R. Grosvenor, and P. Prickett, "A review of the evolution of microcontroller-based machine and process monitoring", International Journal of Machine Tools and Manufacture, vol. 45, pp. 573-582, 2005
- [4] J. M. Alonso, J. Ribas, J. Coz, A. J. Calleja, E. L. Corominas, and M. Rico-Secades, "Development of a distributive control scheme for fluorescent lighting based on LonWorks technology", Industrial Electronics, IEEE Transactions on, vol. 47, pp. 1253-1262, 2000.

[5] J. M. Alonso, P. J. Villegas, J. Diaz, C. Blanco, and M. Rico, "A microcontroller-based emergency ballast for fluorescent lamps", *Industrial Electronics, IEEE Transactions on*, vol. 44, pp. 207-216, 1997. [6] AHMED AfazUddin , KHALED Mohammed Shahriar , ALI Mohammed , RAHMAN Mohammad Mahbubur Controlling and Monitoring of Electric Feeders Using GSM Network Technology

[7] Qinghai Ou, Yan Zhen ,Xiangzhen Li, Yiying Zhang ,LingkangZeng "Application of Internet of things in smart grid power transmission 2012

[8] G. Pudlo, S. Tenbohlen, M. Linders and G. Krost, "Integration of Power Transformer Monitoring and Overload Calculation into the Power System Control Surface", *IEEE/PES Transmission and Distribution Conference and Exhibition, Vol. 1*, pp: 470-474 Asia Pacific, 2002.

