

RFID BASED WOMEN SAFETY SYSTEM

^[1]Mrs. Deepa B, ^[2]Mallikarjunagouda N, ^[3]M Shiva Satish, ^[4]C Priyanka, ^[5]L G Lavanya.

^[1] Assistant Professor, ^[2]^[3]^[4]^[5]Students

Department of Electrical and Electronics Engineering

^[1]^[2]^[3]^[4]^[5]Rao Bahadur Y Mahabaleswarappa Engineering College

Abstract—In recent years, acts of assault and violence against women are rising at a menacing rate. With escalation of female employees in industries and other sectors, it is now becoming a necessity for females to travel at late hours and visit distant and isolated locations as a part of their work regime. However, the exponential increase in assault, violence and attacks against women in the past few years, is posing a threat to the growth and development of women. Defence isn't the only measure that can suffice against this increasing abuse. A security solution that creates a sense of safety among women needs to be devised. In instances of attack, it is largely reported that women are immobilized. There is thus, a need of simpler safety solution that can be activated as simply via RFID and GSM and can instantly send out alerts to the near ones and to family members of the victim. The system can be implemented in the form of a partial wearable and partial portable system, the information is passed to RFID reader which communicates with Arduino microcontroller and through GSM the "help" message is sent to 2 predefined contacts (parents, police).

Keywords — women safety system, automatic messaging system, current location.

I. INTRODUCTION

Many unfortunate incidents have been taking place in woman's case. Problems may come from any direction such as women walking on the road after the work, going to super market or many other reasons for which they go alone. People at home are not sure of their return safely. Another factor is woman die without knowing the reason as they attend excursions and industrial trips conducted by the organizations. It happens due to attacks on woman but not suicides. There might be a situation in which the person has to travel alone a long distance at an odd hour and perhaps even by public transport and may face some danger. At such a time, a personal safety app might not only be wise to have easy access to, it might also give you a lot of confidence needed. There might be a situation that when women had an accident in the late night and there are no one to help and to take care of them. In such situations the person will not be able to tell the situation that he/she facing. And they do not know the basic first-aid details and to know the person where the incident has happened. To escape from the un-wanted meetings we do not know the way to escape from that meeting because we do not know the fake calls working. These are some of the problems that have taken place in the day-to-day life of women. The objective of research work is to create a safety system in the form of a portable safety device for a woman that does the following tasks:

- Alerts family and police and gives location coordinates of the woman being attacked.

In this application we are maintaining a switch. In the worst situation when we press switch at that time with location place will be sent to the android mobile which is enrolled in the memory IC should get a message like help needed. We are using LCD to display on the screen while sending message like (message sending to cell *****).

GPS gives only the longitude and latitude values but by using Android application in the mobile we can easily get the location name from where the message has been sent.

The controller takes the switch as its input i.e. when some threat has occurred one need to press that switch and the controller makes the GSM module to message to the pre-stored number. In this way the concerned person will know the location and they will be able to save the candidate. With a wide range of serial communications interfaces, they are also very well suited for communication gateways, protocol converters and embedded soft modems as well as many other general-purpose applications.

This project uses regulated 5V, 500mA power supply. Unregulated 12V DC is used for relay. 7805 three terminal voltage regulator is used for voltage regulation. Bridge type full wave rectifier is used to rectify the ac output of secondary of 230/12V step down transformer.

II. LITERATURE SURVEY

A. Paper [1]

This work [1] had proposed that it will intimate the parents and police about the current location of the women. A GPS system is employed to trace the present position of the victim and a GSM is employed to send the message to the pre-defined numbers.

B. Paper [2]

This work [2] had proposed about that anytime a woman senses danger, so she has to turn ON the device. Once the device is activated, it tracks the current location of the women using GPS and sends emergency messages using GSM, to already register mobile number and the police control room. The pulse sensor checks the pulse of victim and in abnormal health situation the device also sends current GPS location to ambulance at every 10 sec in form of SMS.

C. Paper [3]

This work [3] had proposed about the violence against women (VAW) and also different health issues of women. We have designed and presented a skeleton of a user-friendly mobile application named Women Empowerment which can

contain totally different laws associated with VAW and additionally contains different health tips for women, who can facilitate will help the rural as well as urban women. It includes emergency system, which will be active by the victim woman once they area unit in peril.

D. Paper [4]

This work [4] had proposed about new model for women security, Once the switch is pressed the current location of women is collected and sends through GSM to the numbers registered in the Arduino, This work [5] had proposed In order to track the location and find the identity of the child a GPS module and a RFID card is used in the proposed system. The system uses Arduino Mega 2560 as main microcontroller.

III. OBJECTIVE

The main objective of this project is

- An embedded system is a combination of software and hardware to perform a dedicated task. Some of the main devices used in embedded products are Microprocessors and Microcontrollers.
- Microprocessors are commonly referred to as general purpose processors as they simply accept the inputs, process it and give the output. In contrast, a microcontroller not only accepts the data as inputs but also manipulates it, interfaces the data with various devices, controls the data and thus finally gives the result.
- The GPS and GSM based women security system using Arduino Microcontroller is an exclusive project that can provide security for women according to the instructions given by the above said microcontroller.

IV. PROBLEM STATEMENT

The main problem is to provide dual security for women as the crime against women are prevalent these days. Today women are working during day and night time as well; hence security has become the major concern. With the increase of crime against women like rape, theft, kidnap, domestic violence, dowry violence, honor killing, acid throwing etc. Therefore, there is no security for women. Hence women security is a prime factor these days. Therefore, the device basically deals with the safety of women during the adverse situations. So, we have come up with a novel device which uses two technologies inter connected via RFID.

V. METHODOLOGY

A. Nowadays Women's safety is a very important issue and rising crimes against women these days. To help resolve this issue we propose a GPS based women's safety system that has a dual security feature. This device consists of a system that ensures alerts in case a woman is harassed or she is in trouble. This system can be turned on by a woman in case she even thinks she would be in trouble. In this project, we have an emergency button. If any incident occurs with a woman, she may or may not get the chance to press the emergency button. In a button press alerting system, in case a woman is hit on the head from behind, she may never get the chance to press the panic button and no one will know she is in trouble. Our system solves this problem. Woman in case she is walking on a lonely road or any remote area or some dark alley. The simple algorithm can be applied for

fall detection by observing any change of x, y, or z mems sensor finds the algorithm.

B. Once started the devices require the woman to constantly observing any changes of x-,y-,z- acceleration on the system every 1 minute, else the system now sends her location to the authorized person a buzzer continuously on so that nearby people may realize the situation. In this case, even if someone hits the woman or the woman falls down and gets unconscious, she does not need to do anything, the system does getting changes continuously in acceleration within 1 minute and it automatically starts the dual security feature. This device will prove to be very useful in saving lives as well as preventing atrocities against women. The device uses GPS sensor along with a Gsm modem, LCD display leads and microcontroller-based circuit to achieve this system.

VI. BLOCK DIAGRAM

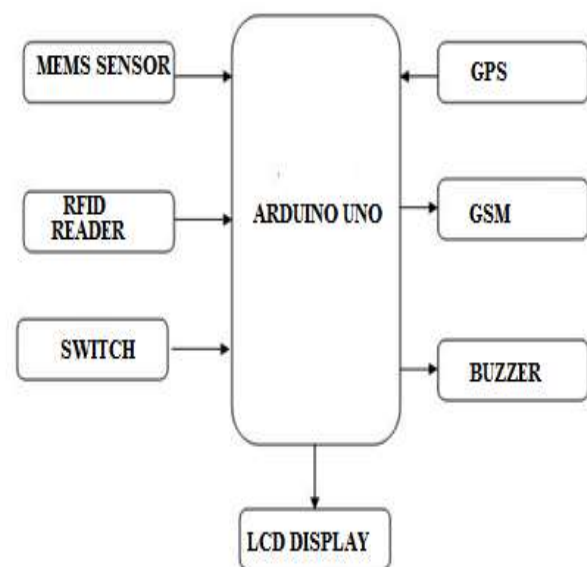
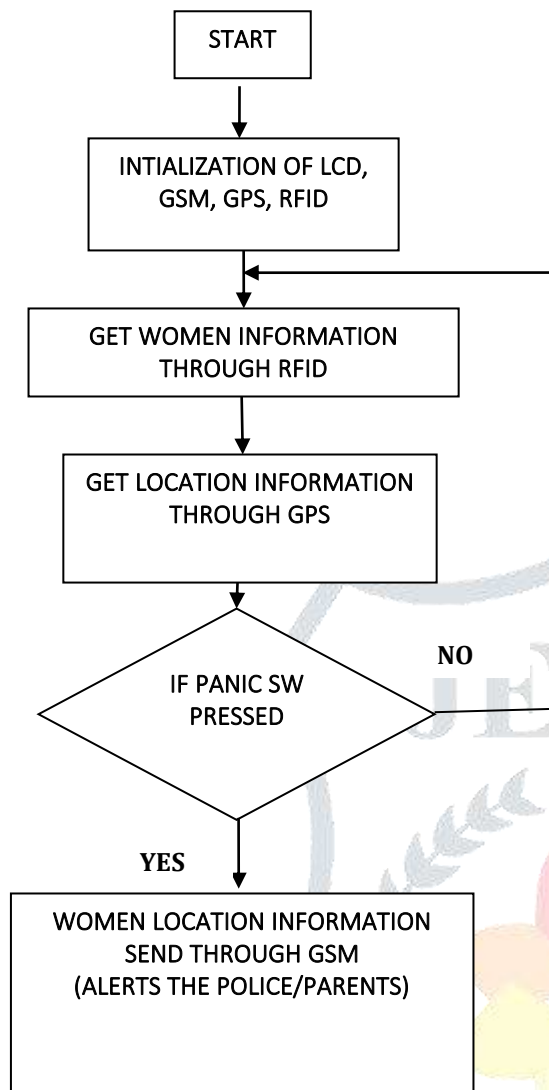

Figure 1: Block diagram



Figure 2: ARDUINO UNO

VII. FLOW CHART



VIII. ADVANTAGES

- It is safe and easy to use
- Low cost
- Less weight (Can be used by children, teenager girls, women, old age people)
- Easy coding & Maintenance (mobile number can be changed at any time)

IX. APPLICATION

- Safety device
- Tracking system
- Alert system

X. RESULT

In this paper, we have proposed the designing and implementation of a safety system for women in the form of RFID card. Going serially as per the objectives mentioned, a location tracking subsystem was successfully implemented and the corresponding results were logged. It allows checking the location of the person using the Tag. The Reader which is embedded in each vehicle recognizes the details of the particular person. When the car picks up the person; he/she needs to swap the RFID card. The micro controller matches the RFID card no with its database records and sends the person id & co-ordinates to the unit via GSM module.

XI. FUTURE SCOPE

Our project “**RFID BASED WOMEN SAFETY SYSTEM**” is mainly intended for detection of burglar’s. This project uses a Mems sensor which is capable of detecting human movements when they are harassed which are emitted by the microelectronic movement detection sensor, an appropriate electrical signal is given as input to microcontroller which in turn sends the alert message to the family/police through SMS with the help of GSM modem interfaced to the Micro Controller.

This project can be extended by using Fire sensor, IR sensor, IoT and 3G technologies. Fire sensor alerts in case of fire accidents. IR module ca also helps in alerting if any presence. Through IoT, we can monitor the women from anywhere in the world and 3G technologies can be used to view the person through video calling option.

CONCLUSION

Integrating features of all the hardware components used have been developed in it. Presence of every module has been reasoned out and placed carefully, thus contributing to the best working of the unit. Secondly, using highly advanced ICs with the help of growing technology, the project has been successfully implemented. Thus, the project has been successfully designed and tested.

REFERENCES

1. Maryam Said Al-Ismaili, Ali Al-Mahruqi, Dr. Jayavrinda Vrindavanam, " Bus Safety System for School Children Using RFID and SIM900 GSM MODEM", International Journal of Latest Trends in Engineering and Technology (IJLTET), Vol. 5 Issue 1 January 2015.
2. Sindhu.A.M,Jerin George,Sumit Roy,Chandra J,"Smart Streetlight Using IR Sensors",IOSR Journal of Mobile Computing & Application,Volume 3, Issue 2.,Mar. - Apr. 2016.
3. Deepak Kumar Rath,"Arduino Based: Smart Light Control System",International Journal of Engineering Research and General Science Volume 4, Issue 2, March- April, 2016.
4. Nitin Shyam, Narendra Kumar, Maya Shashi, Devesh Kumar, "SMS Based Kids Tracking and Safety System by Using RFID and GSM", International Journal of Innovative Science, Engineering & Technology, Vol. 2 Issue 5, May 2015.

5. Mr.Dinesh Kumar HSDK, Shreya Gupta,Sumeet Kumar,Sonali Srivastava, "Accident Detection and Reporting System Using GPS and GSM Module", Journal of Emerging Technologies and Innovative Research (JETIR),Volume 2, Issue 5,May 2015.
6. A.Gowthaman , R.Mohanraj , A.Anadhan , S.Mohan, " Implementation of school children tracking system and transportation safety enhancement by using RFID technique", International Journal of Emerging Technology in Computer Science & Electronics (IJETCSE) ISSN: 0976-1353 Volume 21 Issue 2 – APRIL 2016.

