

IoT based Health Monitoring System

Dr.H.V.Govindaraju
Dept of EEE
Dr.AIT
(Affiliated to VTU)
Bengaluru, Karnataka, India
govind.raju37@yahoo.com

Namratha Sadananda Hegde
Dept of EEE
Dr.AIT
(Affiliated to VTU)
Bengaluru, Karnataka, India
namratahegde0@gmail.com

Neeshu Yadav
Dept of EEE
Dr.AIT
(Affiliated to VTU)
Bengaluru, Karnataka, India
neeshuyadav1999@gmail.com

Neha Kulsum S
Dept of EEE
Dr.AIT
(Affiliated to VTU)
Bengaluru, Karnataka, India
nehakulsums1998@gmail.com

Umar Farooq Lone
Dept of EEE
Dr.AIT
(Affiliated to VTU)
Bengaluru, Karnataka, India
loneumiii16@gmail.com

Abstract— In this paper, we have proposed an IoT based health monitoring system using Arduino UNO and ESP32 Wi-Fi module. IoT is a giant network which connects things and people. It collects and shares data about the way they are used and about the environment around them. In this system, various sensors are used for measuring different parameters such as ECG, Body temperature, Heart Rate, Spo2, Room Temperature and Humidity. The Arduino UNO is used for collecting and processing the data. Then data is uploaded to ThingSpeak using the ESP32 Wi-Fi module. Using this data, condition of the patient's health is monitored by doctors from anywhere in the world. The health monitoring system has become inevitable because of the COVID-19. An increase in body temperature, irregular heart rate and dry cough are some of the critical symptoms of the COVID-19. Our system is helpful in detecting these symptoms and monitoring patient's health status regularly.

Keywords -- Health Monitoring System, IoT, Arduino UNO, ESP32, ThingSpeak, Telegram

1. INTRODUCTION

Good health is indeed the most important thing for everyone. "Health is Wealth" is a very famous saying, which means that where there is health there is wealth. Keeping our body in good health is a difficult task at times. No one can be in good health for long if he/she does not monitor the core vital signs of good health. Continuous monitoring helps patients and doctors to react appropriately by keeping records of blood pressure, body temperature, pulse rate and heart rate. Regular monitoring of health is important. It is challenging to visit the hospitals during pandemics for regular check-ups.

In this paper, we have come up with a design of reliable, low power and cost-effective health monitoring system. This health monitoring system based on IoT is used to send the real-time parameters of the patient's health to cloud using a Wi-Fi module. This system is designed using IoT technology. The combination of IoT and Arduino is advancement in the medical field. Heart rate and Body temperature are the most significant indicators of the human health. AD8232 sensor monitors the electrical activity of the heart. The LM35 sensor monitors human body temperature, which in a healthy adult is likely to range between 97.8- 99 Degree Fahrenheit. MAX30100 sensor monitors the heart rate (60-100 BPM) and Spo2 (95-100%) levels. DHT11 sensor monitors the temperature and humidity of the room. The ESP32 Wi-Fi module sends the sensor data to ThingSpeak so that the data can be accessed from anywhere by the doctors. If the available data exceeds the threshold values then an alert message is sent to doctor's smart device. This system bridges the gap between doctors and patients.

2. COMPONENTS

The components used to rig up this health monitoring system are as follows:

2.1 Major Hardware Components

1. DHT11 Room Temperature and Humidity Sensor

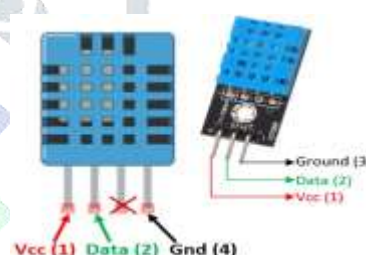

Fig .1 DHT11 Sensor pin-out and features

DHT11 is a low-cost room humidity and temperature sensor, which is used to measure temperature (0-50 Degree Celsius) and moisture (20%-80% with an accuracy of +/- 5%). It uses a capacitive humidity sensor and a thermistor to measure the surrounding air.

DHT11 can be interfaced with any microcontrollers like Arduino, Raspberry Pi and gets instantaneous results. DHT11 sensor is simple to use and it provides high reliability, fast response time, and long-term stability.

2. LM35 Body Temperature Sensor



Fig.2 LM35 Temperature Sensor module

Core body temperature is a vital parameter for determining an individual's health status. The LM35 temperature sensor is the most beneficial and advantageous than that of a clinical thermometer and infrared thermometer. It is because of the fact that it can be used to measure the temperature of the human body through the temporal artery temperature technique. LM35 is a precision integrated circuit temperature sensor, whose output voltage varies based on

the temperature around it. There will be a rise of 10mv for every one degree Celsius rise in temperature. It can be easily interfaced with any microcontrollers that have ADC functions or any development platforms like Arduino.

3. MAX30100 Pulse Oximeter



Fig.3 MAX30100 Pulse Oximeter and Heart-Rate sensor module

The MAX30100 sensor is used to measure oxygen saturation levels in % SpO2 and heart rate in BPM. It is an optical sensor that derives readings from emitting two wavelengths of light from two LEDs, red and infrared. The signal is processed by a low noise analog signal processing unit and communicated to the target MCU through the microbus I2C interface. The accuracy of this sensor is 99.62% for blood oxygen saturation measurements and 97.55% for heart rate when compared with industry-standard devices. It is an integrated pulse oximeter and heart rate sensor solution. Pulse oximetry can help to assess the need for supplemental oxygen in Covid patients.

4. AD8232 Heart Monitor Sensor

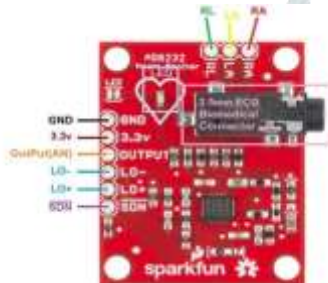

Fig.4 AD8232 Heart-Monitor Sensor module

The AD8232 is used to measure the electrical activity of human heart. It is used to diagnose various heart conditions. Electrocardiograms can be extremely noisy. The AD8232 heart rate monitor acts as an op-amp to obtain a clear signal from the PR and QR intervals easily. The recording of an ECG on standard paper allows the time taken for the various phases of electrical depolarization is measured in milliseconds. The normal range for such intervals is given as PR interval ranges from 120-200ms(3-5 small squares on ECG paper), QRS duration ranges up to 120ms (3 small squares on ECG paper), QT interval ranges up to 440ms.

5. Arduino UNO



Fig.5 Arduino UNO module

The proposed IoT-based Health Monitoring System is developed using an Arduino microcontroller, which is the brain of the project. Arduino is open-source electronics platform based on easy-to-use hardware and software. It can provide serial communication that is available on digital pin 0(RX) and 1(PX). Arduino consists of various components such as serial communication, crystal oscillator, and voltage regulator for supporting the microcontroller. Arduino Uno board is designed in a way that allows it to be reset by software running on a connected computer.

6. ESP32 Development Board



Fig.6: ESP32 Development Board

ESP32 is a series of low-cost and ultra-low-power system on a chip microcontroller with integrated wi-fi and dual-mode Bluetooth. ESP32 is a successor to the ESP8266. It comes with more GPIOs, two CPU cores, faster wi-fi, supports Bluetooth 4.2 and Bluetooth low energy. The ESP32 supports Bluetooth communication protocol by default, and has 2 Xtensa 32-bit LX6 microprocessors. It is a dual-core (core 0 and core1) 160 MHz to 240MHz CPU. ESP32 achieves ultra-low-power consumption with a combination of various types of proprietary software. ESP32 can dynamically remove external circuit imperfections and adapt to changes in external conditions. ESP32 supports multiple programming environments like Arduino IDE, PlatformIO IDE, LUA, MicroPython, Espressif IDE (IoT Development Framework), Javascript.

7. 16x2 LCD Module

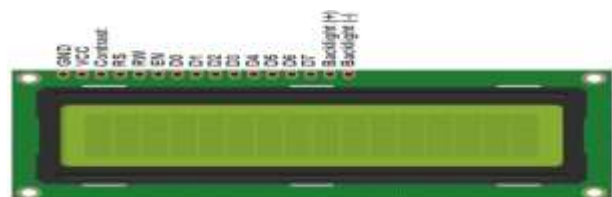

Fig.7: LCD Display module

The 16x2 LCD is a very basic electronic display module widely used in AVR, Arduino, PIC, and 8051 based embedded projects. The LCD display is provided to see the real-time data from the sensors.

2.2 Software Components

1. ThingSpeak

The IoT platform used in this project is ThingSpeak. ThingSpeak is an open-source IoT platform service that allows us to collect, analyze, visualize and store live data streams in the cloud and develops an IoT application. It supports IoT devices like Arduino, MATLAB, Raspberry-Pi and NodeMCU. We can send IoT device data from ThingSpeak cloud for deep analysis. The heart of ThingSpeak is a ThingSpeak channel. We can publish data to this channel, have ThingSpeak process the data, and then have an application to retrieve the data.

2. Arduino IDE

Arduino IDE is open-source software that is mainly used for writing, compiling, debugging the code, and uploading it to Arduino Module. It supports the C/C++ programming language. Arduino IDE is more versatile and needs no special drivers or additional components. Arduino IDE is a cross-platform software that is available for operating systems like Windows, Linux and macOS. It has a cross compiler that compiles for a different target platform. Arduino IDE supports Arduino boards including Arduino mega, Arduino Leonardo, and Arduino Ethernet.

3. Telegram Bots

At the core, Telegram Bots are special accounts that do not require an additional phone number to set up. Users can interact with bots in two ways:

1) Send messages and commands to bots by opening a chat with them or by adding them to groups. This is useful for chat bots or news bots like the official TechCrunch bot.

2) Send requests directly from the input field by typing the bot's @username and a query. This allows sending content from inline bots directly into any chat, group, or channel.

Messages, commands and requests sent by users are passed to the software running on servers. The intermediary server handles all encryption and communication with the Telegram API. We communicate with this server via a simple HTTPS interface that offers a simplified version of the Telegram API. We call that interface our Bot API.

3. METHODOLOGY

Block Diagram

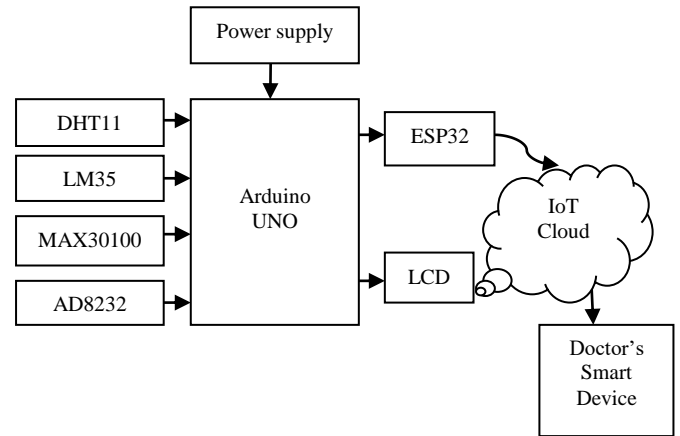

Fig.8: Block diagram of the IoT based Health Monitoring System

Flowchart

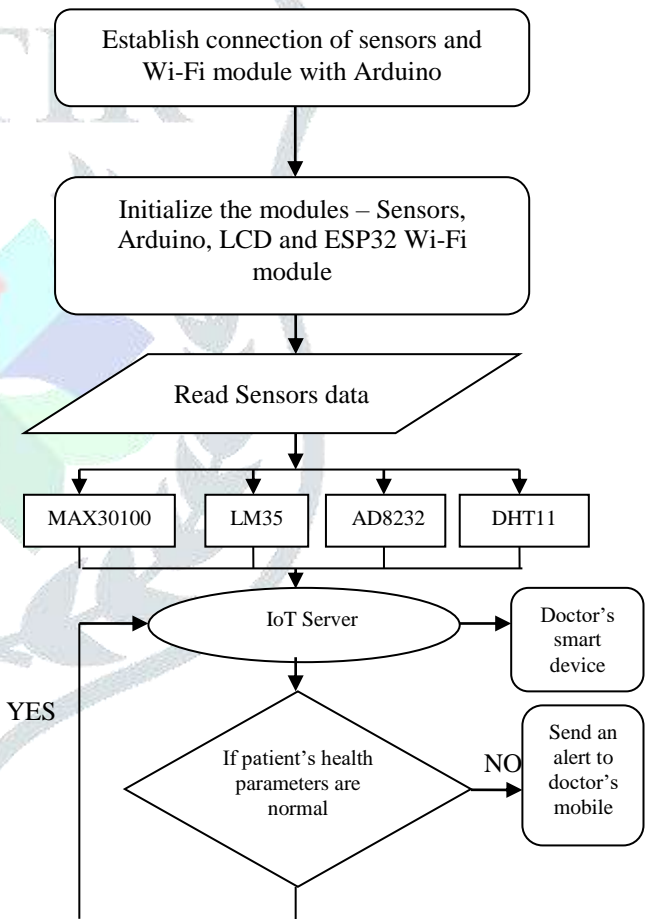

Fig.9: Flowchart of the IoT based Health Monitoring System

In this project, an IoT-based health monitoring system is designed and implemented. DHT11 Room Temperature and Humidity sensor, LM35 Body Temperature sensor, MAX30100 Pulse Oximeter and, AD8232 Heart Monitor sensor are used for measuring different parameters. Sensors sense the data and send it to the Arduino UNO board, which processes the code. Initially, the parameters will be displayed on the LCD, then the ESP32 Wi-Fi module connects to Wi-Fi and sends the data to the IoT device server, which is ThingSpeak. In case of abnormalities in the health data, a message will be sent through the telegram to the doctor.

Outcomes



Fig.10: Outcomes of the project on ThingSpeak platform

Future Scope

A GPS module can be added to this patient health monitoring system so that doctors can track the location of the patient and take the necessary actions when needed.

Smart glucose monitoring and smart insulin pen technologies are not only used to continuously monitor the glucose level but also to upload the data to cloud services or mobile app for analysis. Based on the analysis, the insulin pump can then inject the patient with the appropriate dosage of insulin.

Smart cameras can be used for monitoring elderly patients. The application of this camera is for fall detection, which would then alert emergency services or caregivers. But sometimes false alarms can be generated due to the battery issues of sensors and smartphones the research can be done to resolve this issue.

Conclusion

The future of IoT has a greater opportunity to make a positive impact on the healthcare industry. Beyond the growing market for the healthcare IoT, the Covid-19 pandemic has spurred conversations around the future of IoT in healthcare and how it can safely connect healthcare professionals and patients. The developed IoT-based health monitoring system is an alternative that can be used to help patients with chronic diseases and significantly can improve the individual's quality of life. The patients under critical conditions need to be under observation all the time. Doctors need updates of health-related parameters like body temperature, Heart rate, SpO₂, ECG, and also the temperature and humidity of the room. This system will collect this information with the help of sensors and keeps on updating the health parameters on IoT. Doctors can get the patient's health information from anywhere using smart devices.

References

- [1] Richa, Anwasha Das, Ajeet Kumar Kushwaha and Prof. Mini Sreejeth, "An IoT based Health Monitoring System using Arduino UNO". (IJERT- March 2021)
- [2] Md.Milan Islam, Ashikur Rahman, and Md.Rashedul Islam, "Development of Smart Healthcare Monitoring System in IoT". (Original Research-May 2020)
- [3] K. Latha, G. Sravanth, N.V. Pavan Kumar, B.V. S. Nagarjuna. "An IoT Based Patient Health Monitoring System using Arduino uno" (IRJET-july 2020)

- [4] Pooja Arjun Baad, Pooja Anil Ghadage, Supriya Sayaji Parbat, Ajit D. Mail-vasekar. "IoT Based Health Monitoring System using Arduino" (JECA-2020).
- [5] Shivkumar Dharmoiji, Akshata Anigolkar, and Prof. Shardha M, "IoT based Patient Health Monitoring using ESP8266". (IRJET-March 2020).
- [6] Prajoona Valsalan, Tariq Ahmed Barham Baomar, and Ali Hussain Omar Baabood, "IoT Based Health Monitoring System". (Journal of Critical reviews- January 2020)
- [7] Ashikur Rahaman, Md. Milan Islam, Md. Rashedul Islam, Muhammad Sheikh sadi, Sheikh Nooruddin. "Developing IoT Based Smart Health Monitoring Systems: A review" (IETA- December 2019)
- [8] Muhammad Sajjad, Shahryar Shafique Qureshi, Muhammad Afnan, "IoT Based Health Monitoring System using Arduino UNO , GSM SIM900D module and Wi-Fi module ESP8266" (IJSER-December 2018)
- [9] Shivleel Patil, and Dr. Sanjay Pardeshi, "Health Monitoring System using IoT". (IRJET-April 2018)
- [10] Pawan Singh, "Internet of Things based Health Monitoring System: Opportunity and Challenges". (January-February 2018)