

AN AIDING HAND FOR DUMB

¹Atiya Sultana,²Muneeb Afzal C,³Gauravi Shetty

¹Assistant Professor,² Assistant Professor,³ Assistant Professor
^{1,2,3}Department of Electronics and Communication Engineering,
^{1,2,3}Navodaya Institute of Technology, Raichur,India

Abstract : The main aim is making a gadget system for the physically disabled people. Deaf and dumb people face lot of difficulty to communicate with persons who do not understand sign language. The Hand Talk glove consists of driving cloth glove fitted with flex sensors along the length of each finger and the thumb. The sensors produces data that varies with degree of bend of each finger. Analog values from the output of sensor is converted to digital form and processed further using microcontroller and then it will be transmitted through wireless communication (RF), the Receiver section receives the signal and process further using responds in the voice using speaker.

IndexTerms - Glove with Flex Sensor, Arm MC, Voice Module, Lcd, Sign Recognition, Keil C.

I. INTRODUCTION

The Deaf people find it difficult to communicate with others like who don't understand sign language. There has been much development in the past years keeping in account the special needs of people. A technology that empowers a person with a learning disability to make up for specific deficits is an assistive technology. Technology to incorporate would usually range between the simple low-level relates well to those with special needs. Research on assistive technology will need variety of people's categories. It will point the subjects with specific needs, their families and parents, professionals, policy makers, corporate executives, and the government sector. Successful research will need the requirement of the cooperation from parental groups, academic institutions, international organizations, non-government organizations, universities, and private centers. The sight of making use technology in peculiar needs is to contribute to the possibilities of acquiring of assistive technologies in particular centers or to the preparation for inclusive education.

II. OVERVIEW

Existing System

- Manual operation
- Persons actions are difficult to understand
- Conveying information to take more time

Proposed System

- Systematic and flexible approach
- Compact system
- Conveying information to others are easy
- Easy way of sensing signal
- Lower to barrier communication

Hardware Used

- Flex sensor
- LPC2148 microcontroller
- TWS434 transmitter to WS434 receiver
- HT-12D decoder.
- SD1820 voice module

Software Used

- Keil C

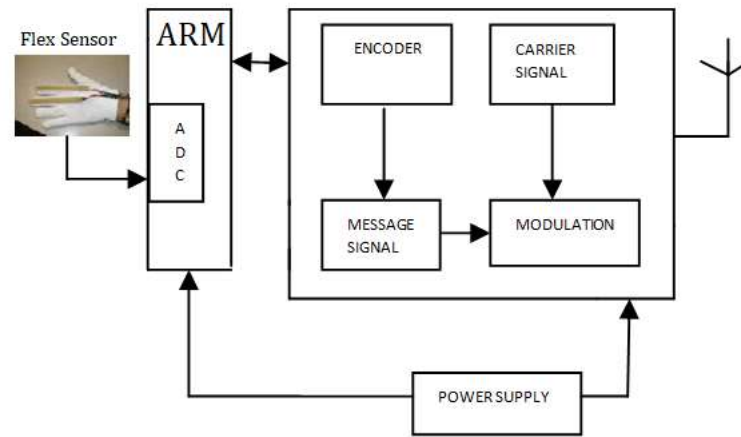

Fig 1 Transmitting block

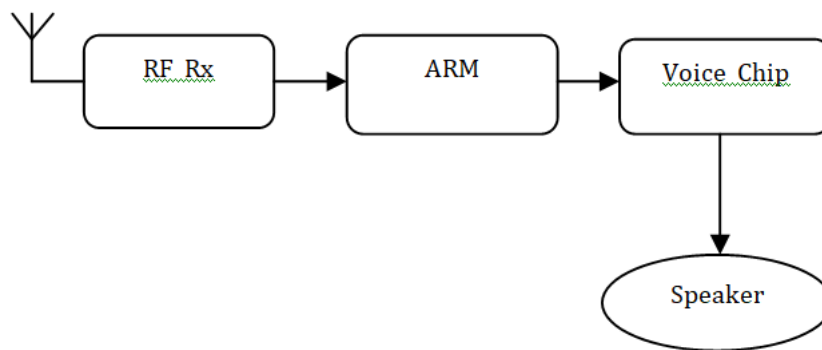

Fig 2 Receiving block

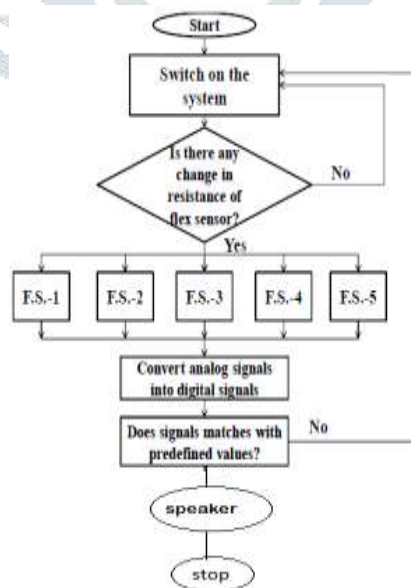

Fig 3 Flow chart

A flex sensor plays the major role. Sensor convert the change in bend to electrical resistance-the more bend the more resistance value. They are often used in gloves to sense the finger movements. They work as variable analog voltage dividers and they require a 5 volt input and output between 0 to 5 volts, the resistivity varying with sensors degree of bend and the voltage output changing accordingly.

The sensors are connected to the LPC2148 microcontroller which has built in ADC. The ADC converts the analog signal to digital pattern.

The LPC2148 microcontroller is based on RISK architecture. Executing of powerful instructions within single clock cycle, achieves throughput and allows to optimize power consumption versus processing speed.

In this system we use radio frequency signal to transmit the signal from TWS434 transmitter to WS434 receiver which is connected to microcontroller.

The output of LPC2148 microcontroller is applied to voice module. If the signal matches with the prerecorded voice signals which are stored in non-volatile memory of voice module, then the corresponding voice signal is produced by speaker.

III. EXPERIMENTAL SET UP AND RESULTS

3.1 Set Up

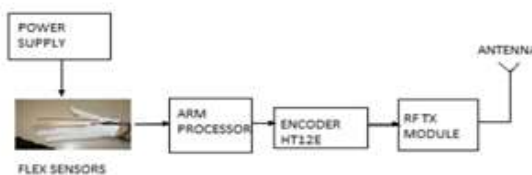

Fig.4 Transmitting side

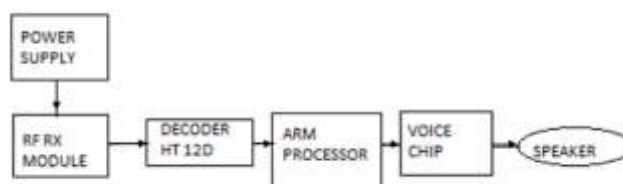

Fig.5 Receiving side

3.2 RESULTS

I 99.3%	G 84%	B 99.2%	S 60.3%
A 99.2%	Q 92%	C 95.5%	L 98%
H 95.8%	U 96.6%	M 90.2%	P 94.2%
N 95.4%	R 92.2%	K 84.3%	W 98.6%

IV. CONCLUSION

The developed helping aid resulted in giving an user friendly approach to the speech impaired people. The user dependent system provided an accuracy of 90 percent. This system helps the speech impaired people and for the bedridden deaf and dumb people to express their need and announce their requirements. As per the results of experiment, we developed this proposed concept and thus it is practically possible. Hence this system will help the people who are physically challenged to a higher extent and also improves the sophistication in driving. MEMS (Micro Electro Mechanical System) are system which are similar to conventional electromechanical systems but are built in the size of a few microns. They can perform the function of electromechanical systems like motion or acceleration detection. The added advantage with MEMS is that the size of such systems is very compact and hence can be used for a lot of applications which are otherwise not possible. This research aims at using a device based on MEMS for developing helping system for the physically challenged people who are partially paralyzed or unable to walk and are restricted to a bed and are also unable to speak. In this research a system is built which will enable them to control the most frequently required things which could be devices like the lighting in the room or other electrical devices.

REFERENCES

- [1] D. Kornack and P. Rakic, "Cell Proliferation without Neurogenesis in Adult Primate Neocortex," *Science*, vol. 294, Dec. 2001, pp. 2127-2130, doi:10.1126/science.1065467.
- [2] M. Young, *The Technical Writer's Handbook*. Mill Valley, CA: University Science, 1989.
- [3] R. Nicole, "Title of paper with only first word capitalized," *J. Name Stand. Abbrev.*, in press.
- [4] K. Elissa, "Title of paper if known," unpublished.

