

IoT Based Industrial Automation Control System Using Arduino

¹Veeraballi Prasanti, ²T.Venkataramana

¹PG Scholar, Department of ECE, Siddartha Educational Academy Group of Institutions, Tirupati, Andhra Pradesh, India.

²Assistant professor, Department of ECE, Siddartha Educational Academy Group of Institutions, Tirupati, Andhra Pradesh, India

Abstract: Today, Automation plays an important role in human life. Industrial Automation allows us to monitor and control Industrial appliances like machines, motors, fans, lights and AC etc. It also provides security to the industries. Industrial Automation is not only meant for human efforts but also for energy efficiency and time saving. The main objective of industrial automation is to monitor and control all the industrial appliances and to alert the employees in critical situations. This paper put forwards the design of industrial Automation using Arduino with the help of Internet of Things (IOT). The proposed system is to find the gas leakage and flame, temperature and humidity and light intensity of the industry. This project uses MQ4 Sensor, DHT11 Sensor, LDR and Flame Sensor to detect the Gas, Temperature/Humidity, Light intensity and fire of the industry. And also two touch sensors is used to control the machine 1 and machine 2. The industrial appliances are connected to the Arduino processor and the communication is done through internet. The status of the appliances can be viewed in a webpage. The cost of the system is very low.

Index Terms – Industrial Automation; DHT 11, Flame Sensor, Internet of Things; Arduino

1. INTRODUCTION

Recently, human's work and life are increasingly tight with the rapid growth in the development of communications and information technology. The society has changed human being's way of life as well as challenged the traditional residence and also living standard keeps raising up day by day that people have a higher requirement for abode functions. Industrial automation is the use of control systems that handles different processes and machineries in an industry to replace a human efforts. The purpose of automation was to increase productivity and to reduce the cost associated with human operators. Nowadays, the focus of automation has shifted to increasing quality and flexibility in a manufacturing process. Industrial automation eliminates healthcare costs and paid leave and holidays associated with a human operator. Although it is associated with a high initial cost it saves the monthly wages of the workers which leads to substantial cost savings for the industry. The maintenance cost associated with machinery used for industrial automation is less because it does not often fail. If it fails, only computer and maintenance engineers are required to repair it. Industrial automation fulfills the aim of the industry to run a manufacturing plant for 24 hours in a day 7 days in a week and 365 days a year. This leads to a significant improvement in the productivity of the industry. Automation alleviates the error associated with a human being. It produces better outcomes because of less errors. Industrial automation can make the production line safe for the employees by deploying robots to handle hazardous conditions.

2. INTERNET OF THINGS TECHNOLOGY

Internet of Things Technology The Internet of Things (IoT) is the network of physical objects that enables these objects to collect and exchange data through internet. The Internet of Things allows objects to be sensed and controlled remotely across existing network infrastructure, creating opportunities for more direct integration of the physical world into computer based systems, and resulting in improved efficiency, accuracy and economic benefit; when

IoT is augmented with sensors and actuators, the technology becomes an instance of the more general class of cyber-physical systems, which also encompasses technologies such as smart grids, smart homes, intelligent transportation and smart cities. Each thing is uniquely identifiable through its embedded computing system but is able to interoperate within the existing Internet infrastructure.

3. METHODOLOGY

A. Existing System

Currently there are no systems at cheaper prices. Various systems are very hard to install and difficult to maintain. The various existing systems are described below have some of the demerits.

1. Java-based automation system through World Wide Web integrated into a PC-based server at home:-In this system the drawback is PC should always on & connect to the server. The Implementation cost is very high.
2. Home automation system by using Bluetooth:- This system drawback is limited range and limited no of devices to be connected. The power consumption Bluetooth enabled devices was high.
3. Home automation system by using Zig bee:-This system is implemented based on Bluetooth. It overcomes some of the drawbacks of Bluetooth system but it is also lack of range.
4. Home automation system using GSM:-After rapid growth of GSM networks this system is implemented. Compared from above system this system consumes less power & standalone but the drawbacks are when GSM networks fails to deliver the commands in time major problems occurs.

Only less numbers of standards for an industrial. So we are developing the industrial automation which monitors and controls the different appliances from the remote place through the IoT.

B. Proposed System

In our proposed scheme we are using Arduino as a main controller. Controller gets the data from industrial environment and process the data to run the industrial appliances smoothly. Normally temperature in industrial environments are high when compared to normal situation because industrial machines produces more heat, which affects the machineries. Temperature sensor monitors the temperature and give the values to Controller. Based on the value either the fan is switched ON or OFF through Relay Module. Further we can monitor and control the industrial appliances through internet. To send the information to internet Ethernet shield is used.

B. TEMPRATURE AND HUMIDITY SENSOR

DHT11 Temperature and Humidity Sensor include a temperature and stickiness sensor complex with an adjusted computerized flag yield. By utilizing the selective advanced flag securing strategy and temperature and dampness detecting innovation, it guarantees high unwavering quality and astounding long haul soundness. This sensor incorporates a resistive-type moistness estimation part and a NTC temperature estimation segment, and interfaces with an elite 8-bit microcontroller, offering amazing quality, quick reaction, hostile to impedance capacity and cost-viability.

4. IMPLEMENTATION

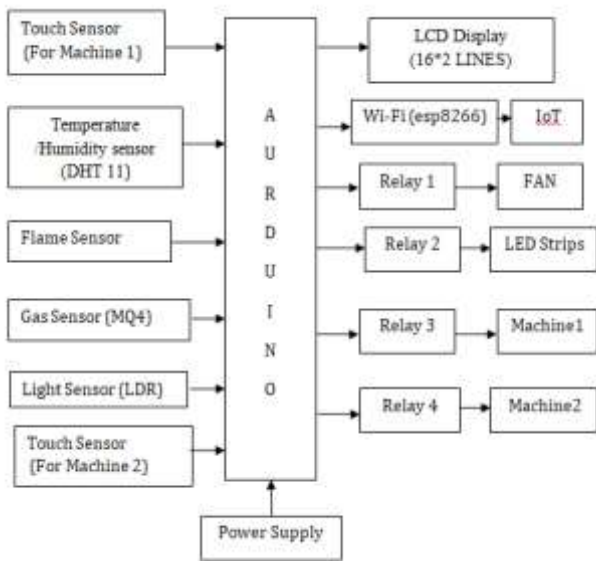

Fig.1 Proposed Block diagram

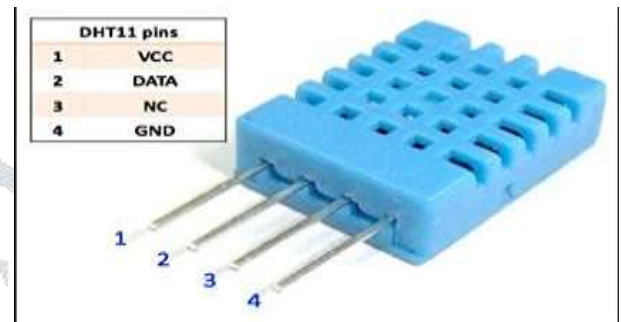

Fig.3 Temperature and Humidity Sensor

C. Wi-Fi

The WiFi module used in our system will help us to operate the web page for a customer.

□ The customer can set a particular threshold value to limit the meter reading through these which will be interfaced with the help of MAX232 to arduino board



Fig.4 Wi-Fi Board

A. Arduino

Arduino/Genuino Uno is a microcontroller board based on the ATmega328P (datasheet).

It has 14 digital input/output pins (of which 6 can be used as PWM outputs), 6 analog inputs, a 16 MHz quartz crystal, a USB connection, a power jack, an ICSP header and a reset button.



Fig.2 Arduino Board

D. Flame Sensor



Fig.5 Flame Sensor

A flame detector is a sensor designed to detect and respond to the presence of a flame or fire, allowing flame detection. Responses to a detected flame depend on the installation, but can include sounding an alarm, deactivating a fuel line (such as a propane or a natural gas line), and activating a fire suppression system. When used in applications such as industrial furnaces, their role is to provide confirmation that the furnace is working properly; it can be used to turn off the ignition system though in many cases they take no direct action beyond notifying the operator or control system. A flame detector can often respond faster and more accurately than a smoke or heat detector due to the mechanisms it uses to detect the flame.

E. Light Sensor (LDR)

Light dependent resistors (LDR), are light sensitive devices most often used to indicate the presence or absence of light, or to measure the light intensity. LDRs have a sensitivity that varies with the wavelength of the light applied and are nonlinear devices.

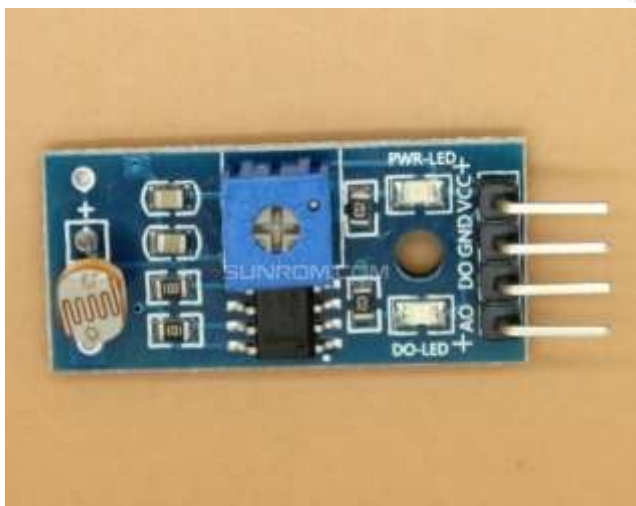

Fig.6: LDR

F. Touch Sensor

A touch sensor is an electronic sensor used in detecting and recording physical touch. Touch Sensors are the electronic sensors that can detect touch. They operate as a switch when touched. These sensors are used in lamps, touch screens of the mobile, etc... Touch sensors offer an intuitive user interface.



Fig.7 Touch Sensor

G. Relay Module

A **relay** is an electrically operated switch. It consists of a set of input terminals for a single or multiple control signals, and a set of operating contact terminals.



Fig.8 12 V Relay Module

H.LCD

LCD stands for liquid crystal display, which is used to show the status of an application, displaying values, debugging a program, etc. A 16x2 LCD means it can display 16 characters per line and there are 2 such lines. In this LCD each character is displayed in 5x7 pixel matrix. The 16 x 2 intelligent alphanumeric dot matrix display is capable of displaying 224 different characters and symbols. This LCD has two registers, namely, Command and Data.

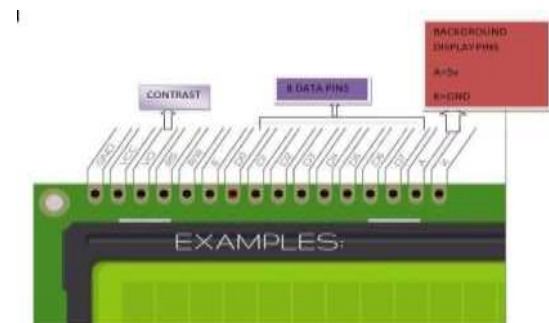

Fig.9 16x2 LCD Display

5. EXPERIMENTAL RESULTS

By implementing this we can increase the lifetime of devices and machineries are monitored and controlled remotely

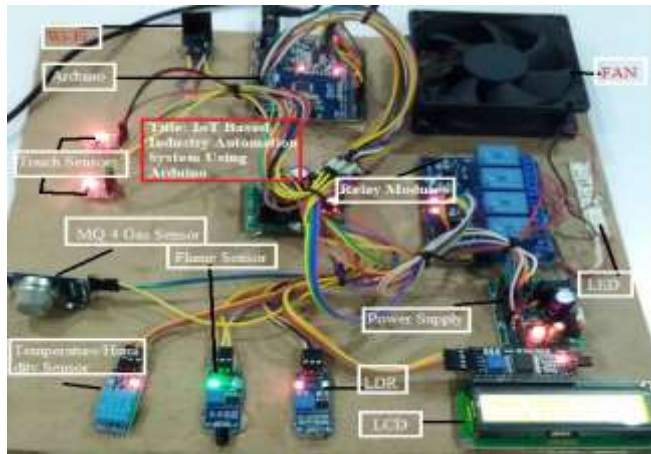

Fig.10 practical prototype model



Fig.13. LCD Showing the Temperature value



Fig.11 LCD Showing the Retriving the data from Sensors



Fig.14 Sensors data sending to Cloud that displayed in LCD



Fig.12 LCD Showing the Temperature value

6. CONCLUSION

In this paper we have introduced design and implementation of a low cost, flexible and wireless solution to industrial automation. The system is secured for access from any user or intruder. This system can be used as a test bed for any industrial appliances that we can access from anywhere through internet.

The full functionality of the industrial automation system was tested and the wireless communication between an Wi-Fi and Arduino. For future work further we can try to reduce the energy consumption and implementation complexity.

REFERENCES

1. N. Sriskanthan and Tan Karand. "Bluetooth Based Home Automation System". *Journal of Microprocessors and Microsystems*, Vol. 26, pp.281-289,2002.

2. Muhammad Izhar Ramli, Mohd Helmy Abd Wahab, Nabihah, "Towards Smart Home: Control Electrical Devices Online" ,Nornabihah Ahmad International Conference on Science andTechnology: Application in Industry and Education(2006)
3. Al-Ali, Member, IEEE & M. AL-Rousan, "Java-Based Home Automation System" IEEE Transactions on Consumer Electronics, Vol. 50, No.2, MAY, 2004.
4. Pradeep.G, B.Santhi Chandra, M.Venkateswarao, "Ad-Hoc Low Powered 802.15.1 Protocol Based Automation System for Residence using Mobile Devices", Dept. Of ECE, K L University, Vijayawada, Andhra Pradesh, India IJCST Vo l. 2, SP 1, December, 2011.
5. Yavuz, B. Hasan, I. Serkan and K. Duygu. "Safe and Secure PIC Based Remote Control Application for Intelligent Home". *International Journal of Computer Science and Network Security*, Vol.7, No.5, May, 2007.
6. Amul Jadhav, S. Anand, Nilesh Dhangare, K.S. Wagh "Universal Mobile Application Development (UMAD) On Home Automation". Marathwada Mitra Mandal's Institute of Technology, University of Pune, India Network and Complex Systems ISSN 2224-610X (Paper) ISSN 2225-0603 (Online) Vol 2, No.2, 2012.
7. Rana, Jitendra Rajendra and Pawar, Sunil N., "Zigbee Based Home Automation "(April 10, 2010).
8. R.Piyare, M.Tazil "Bluetooth Based Home Automation System Using Cellphone", 2011 IEEE 15th International Symposium on Consumer Electronics.
9. Das, S.R., Chita, S., Peterson, N., Shirazi, B.A., Bhadkamkar, M., "Home automation and security for mobile devices," IEEE PERCOM Workshops, pp. 141-146, 2011.
10. S.D.T. Kelly, N.K. Suryadevara, S.C. Mukhopadhyay, "Towards the Implementation of IoT for Environmental Condition Monitoring in Homes", IEEE, Vol. 13, pp. 3846-3853, 2013.
11. Chan, M., Campo, E., Esteve, D., Fourniols, J.Y., "Smart homes-current features and future perspectives," Maturitas, vol. 64, issue 2, pp. 90- 7, 2009.