



## REVIEW ON APPLICATIONS OF VORTEX TUBE REFRIGERATOR

Sudarshan S. Nangare<sup>1</sup>, Dr. Vilas Pharande<sup>2</sup>, Suraj. S. Ghadage<sup>3</sup>

1- PG student, 2 – Principal, 3 - Assistant Professor

Arvind Gavali College of Engineering, Satara

### ABSTRACT

A vortex tube is a device that separates hot and cold streams using pressurized intake gas. Energy separation is the term for this occurrence. Since the invention of the vortex tube in 1933, there has been a massive amount of literature on the subject. Many academics throughout the world are interested in improving the device's performance and understanding the basic mechanism of energy separation. The ability to produce hot/cold gases without the need of a mechanical device, on the other hand, has found interesting applications in the literature. This review paper suggests that vortex tubes be used in a variety of applications. Every application's operational parameters are tabulated and investigated. The reader will find a fascinating choice in recovering energy from pressurized gas and the ability to meet certain applications required in a particular industry in this collection of papers on counter-flow vortex tubes targeted towards the application.

### KEYWORDS:

Vortex Tube, nozzle, material, cone valve angle

### INTRODUCTION

Refrigeration is a practical application of thermodynamics in which heat is transported from a low to a high temperature zone using a working fluid called refrigerant. However, the refrigerants employed have caused environmental issues such as ozone depletion and global warming, prompting us to consider nonconventional solutions. The vortex tube is one of the non-traditional refrigeration devices that uses air as the working fluid. A vortex tube is a simple mechanical device that turns a high-pressure gas stream into two distinct flows of differing temperatures (cold and hot). Compressor, pressure gauge, control valve, thermocouple, and temperature indication make up the Vortex tube. The compressor's compressed air enters the vortex tube tangentially. Swirling flow occurs in the vortex chamber due to tangential entry of compressed air into the vortex tube. In a vortex tube, compressed air expands and splits into cold and hot streams. The cold air exits through the cold end orifice, which is located near the inlet nozzle, and the hot air exits through the hot end orifice. Thermocouples are used to measure temperature at both the cold and hot ends of a circuit. No moving parts, no chemicals, no electricity, cheap cost, light weight, maintenance free, robust, and temperature adjustable are just a few of the benefits of the Vortex tube. Vortex tubes are commonly used in commercial applications to cool electronic parts, test thermal sensors, set solders, cool electric or electronic control cabinets, and cool cutting tools.

### LITERATURE REVIEW

When gas at high pressure and room temperature is fed at the input, the Ranque–Hilsch vortex tube (Figure 1) produces cold gas at one end of the tube and hot gas at the other. The temperature separation generated by the energy separation induced by the flow-field inside the vortex tube is referred to as temperature separation. This temperature separation is determined by the amount of gas emitted from the cold end, or the cold gas fraction, which is defined as the ratio of departing cold gas mass flow rate to inlet mass flow rate. The ratio of real total temperature drop between inlet and cold end to isentropic total temperature decrease happening at intake is a regularly observed performance metric. Due to environmental concerns, the vortex tube is one of the alternative ways being studied for refrigeration. The use of a vortex tube as a refrigerator is rendered inefficient due to its low COP. Vortex tubes, on the other hand, have the advantage of being simple to create and operate with no moving parts. This is an appealing option because it requires little maintenance. French physicist Georges Ranque (1933) devised the vortex tube device in 1933, and it was patented in 1934. Rudolf Hilsch, a German physicist, increased the thermal performance (1947). The interest in this device has increased thereafter due to its niche applications. This is evident by the experiments carried out to understand the mysterious temperature separation and flow field established in the vortex tube.

The studies on temperature separation under theoretical, experimental, and numerical work have so far been included in review papers (Eiamsa-arda and Promvongse 2008; Xue, Arjomandi, and Kelso 2010; Subudhi and Sen 2015; Hitesh, Monde, and Ashok 2015; Karthikeya Sharma et al 2016; Zhang and Xiangji 2018). Smith and Pongjet (2008) examined prior work on

temperature separation in the vortex tube, including tests and simulations. The geometrical characteristics of the vortex tube (for example, the diameter and length of the hot and cold tubes, the diameter of the cold orifice, shape of the hot (divergent) tube, number of inlet nozzles, shape of the inlet nozzles, and shape of the cone valve) were the first important parameter in the experiment. The second section focuses on thermophysical characteristics such inlet gas pressure, cold mass fraction, input gas moisture, and gas type (air, oxygen, helium, and methane). The temperature separation mechanism and flow-field inside the vortex tubes are investigated for each parameter by monitoring the pressure, velocity, and temperature fields. The quantitative, theoretical, analytical, and numerical (finite volume approach) components of the topic are the focus of the computation review. Xue, Arjomandi, and Kelso (2010) conducted a rigorous examination of current hypotheses for how a vortex tube works. Pressure, viscosity, turbulence, temperature, secondary circulation, and acoustic streaming hypotheses are examined. Subudhi and Sen (2015) focused on the variables of interest and curve fitting equations utilising literature data to produce an approximate estimate of temperatures obtained, which can be used in practise for early vortex tube construction. Hitesh, Monde, and shok (2015) aimed to present experimental and numerical work, as well as numerous optimization studies employing techniques such as Artificial Neural Network (ANN) and Taguchi method, conducted by various scholars. Sharma, Rao, and Murthy (2017) presented a computational examination of vortex by a number of researchers, along with the results and recommendations for improving the vortex tube's performance. To predict the energy separation in a vortex tube, turbulence models such as LES,  $k-\epsilon$ ,  $k-\omega$ , and RMS were explored. There are other studies on artificial neural networks (ANN) and Taguchi methods are also covered. Zhang and Xiangji (2018) highlighted the potential contributions of Ranque–Hilsch vortex tubes in meeting the industrial requirements of energy efficiency Improvement, sustainable energy utilization, and waste heat regeneration with its unique energy separation effect. Zhuohuan et al. (2020) reviewed mainly on the energy separation principle, the design criteria of vortex tubes, and practical application. Most of the review articles on vortex tube cover the experimental and numerical aspects on the analysis of energy separation mechanism in the vortex tube. The researchers have extended the working range of vortex tube towards certain utilities to showcase the ability of vortex tube in meeting the requirements of the applications.

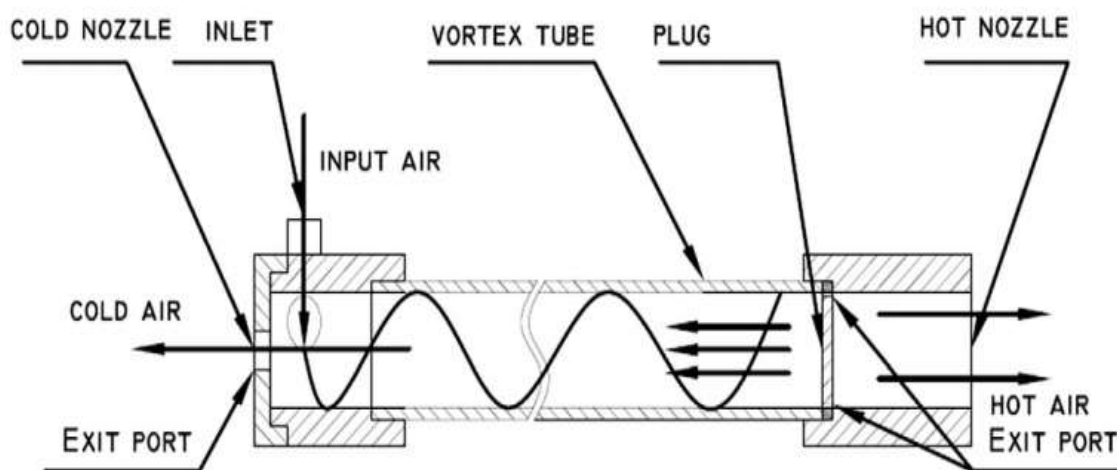

Fig.1 Airflow structure in a counter-flow vortex tube [2]

### APPLICATIONS OF VORTEX TUBE REFRIGERATOR

The use of vortex tube for small capacity applications is always justified if the compressed air is readily available. The vortex tube has a no. of features that make it attractive for industrial applications. Firstly, having no moving parts, it is highly reliable device. Secondly, it requires no external power such as electricity or flames in order to operate, making it a comparatively safe source of heating or cooling the following few specific applications of vortex tube are described. The vortex tube is therefore ideal for use in environments where maintenance is difficult or where safety is critical. Nuclear reactors represent a situation fulfilling both these criteria.

#### 1. Cooling an ultrasonic weld:

A manufacturer of toothpaste seals the ends of plastic tubes with an ultrasonic welder prior to filling. As heat built up at the sealing jaw of the welder, release of the tubes was delayed. Tubes that were too hot would not seal resulting in a high rate of rejection. Vortex Tube was used to direct cold air at the jaw of the welder. The cooling was transferred through the metal jaw to the tube seam while in the clamped position. Process time was reduced and rejected tubes were eliminated [12].

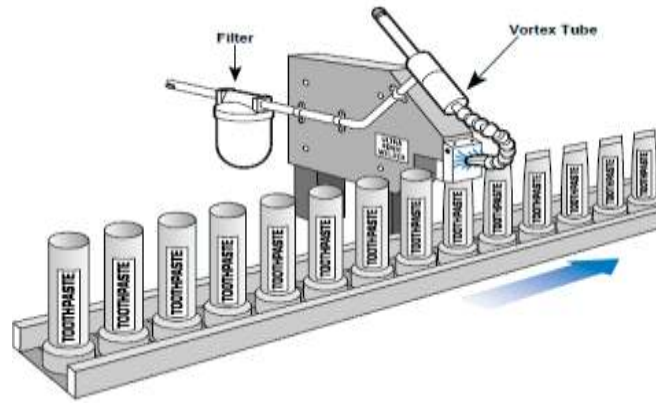

Fig.2 Cooling an Ultrasonic Weld

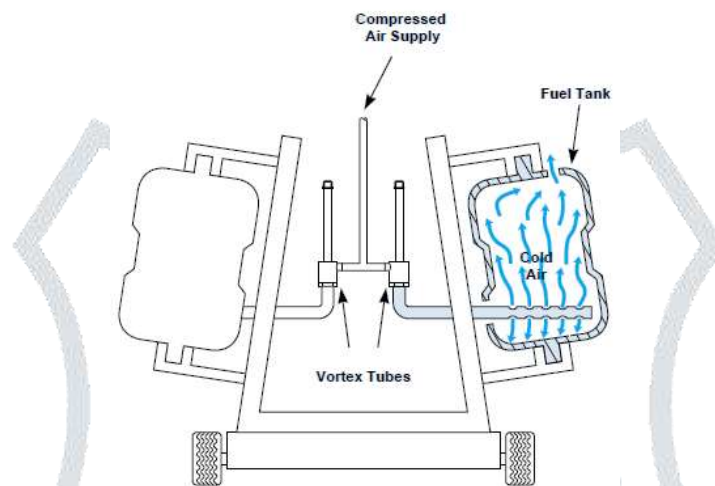

Fig. 3 Cooling Blow Molded Fuel Tanks.

2. Cooling blow molded fuel tanks

Automobile fuel tanks are blow molded, then clamped to a fixture to prevent distortion during the cooling cycle. The cooling time of over 3 minutes required for each tank created a bottleneck in the production process. Vortex Tubes were mounted to the cooling rack and connected to a compressed air line. Cold air produced by the vortex tubes was circulated inside the fuel tanks. Cooling time was reduced from three minutes to two minutes for each tank, improving productivity by 33% [12].

3. Cooling small parts after brazing:

Air conditioner parts assembled on an automatic brazing machine must be cooled to handling temperature prior to removal. The machine was capable of brazing up to four hundred pieces per hour. However, the time required for the parts to cool severely limited the production rate. Water cooling was unacceptable from the standpoint of both housekeeping and part contamination

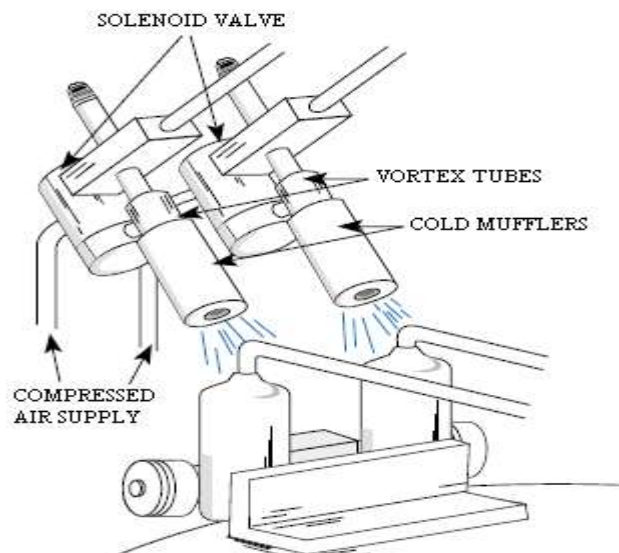

Fig.4 Cooling Small Parts after Brazing



Vortex Tubes (with cold air muffler installed) were used to blow cold air on the parts after the brazing cycle. The vortex tubes were set at an 80% cold airflow (cold fraction) to produce maximum refrigeration. The parts were cooled from brazing temperature of 1450° F (788° C) to handling temperature of 120° F (49° C) within 20 seconds, allowing the machine to operate at its maximum production rate [12].

#### 4. Cooling vacuum formed parts:

A manufacturer of major appliances vacuum forms the plastic interior shell of refrigerators. The deep draw of the plastic and complex geometry left the four corners unacceptably thin. The corners would tear during Assembly or bulge when insulation was inserted between the shell and exterior housing, resulting in a high rejection rate [12]. Vortex Tubes were positioned to cool the critical corner areas just prior to forming the plastic sheet. By cooling these areas, less stretching of the plastic occurred which resulted in thicker corners.

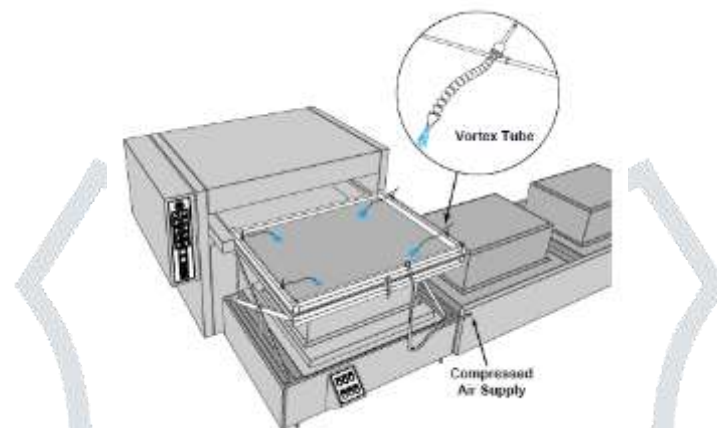

Fig. 5 Cooling Vacuum Formed Parts

#### 5. AIRSUITS

Air cooled suits are used by the operators entering the vessels, tanks and pits where it is dangerous due to concentration of toxic vapors, fumes or dust. Workers working in coalmines and foundries commonly use it. It is not always economical to condition the hot place like foundries, where the heat load is considerably large. Presently the largest single use is cooling unit for protective clothing and helmets for jobs such as sand blasting, welding & handling toxic materials. Simply connecting a vortex tube to an airline and attaching it to the suit can cool these garments & helmets. The air in the air suit is supplied to the mask and the top half of the suit to maintain normal body temperature. The air supply to the suit can be cooled or warmed by the vortex tube. The supply of the air can be adjusted quickly and easily. The safety and comfort provided by such a suit can avoid fatigue resulting from unpleasant conditions. This is an ideal application of vortex tube where lightness, compactness and simplicity are of prime importance [12].

#### 6. AVIATION

The cabin of high-speed gas turbine powered air planes are cooled with the use of bootstrap air cycle. The vortex tube can also be used for the same purpose with less efficiency, as more air would have to be bled off from the compressor at high pressure as compared with bootstrap cycle for the same cooling capacity. The use of vortex tube would result in overall reduction in weight, which is of prime importance. The use of vortex tube in military aircraft may have marked advantage over all other systems as the small cockpit to be cool [13].

#### 7. COOLING OF GAS TURBINE ROTOR BLADES:

The research is going on from last 25 years to find out effective and efficient method for cooling the gas turbine rotor blades. The cooling of blades by passing the air through no. of radial holes provided for the purpose, successfully used in gas turbines, used for aircraft and marine purposes. The cycle efficiency and specific output both can be improved with the same quantity of air but at lower temperature which can be made available with the help of vortex tube. The compressed air can be bled from the main compressor [13].

#### 8. LABORATORY SAMPLE COOLER:

Cooled air from the vortex tube is circulated inside a rectangular box and the temperature inside is maintained below atmosphere. A sample, which is to be cooled, is kept in this box for specific time. This type of cooler is very much useful in laboratories and research institutes [13].

#### 9. SHRINK FITTING:

Shrink fitting usually require refrigeration for a short period. Most factories have compressed air circuits and vortex tube could be connected at numerous points in the circuits where it is required [13].

**10. CUTTING TOOLS:**

Many vortex tubes are used to cool machine operations over a small area, e.g. many tubes are used to cool machine operations like drilling, milling, turning, etc. As a rule those materials which are difficult to machine are poor conductors of heat. Therefore in machining operations heat does not readily flow away from machining site and the tool overheats, causing excessive tool wears. Even a few degrees of tool cooling by vortex tube can increase the tool life, improves surface finish and allows higher cutting speeds. Some materials are best cut without any lubrication [13].

**11. SPOT COOLING:**

The use of vortex tube is more beneficial for spot cooling. This is generally used in Supersonic aircraft because of saving in weight, saving in space and simplicity of construction and control [13].

**12. I.C. ENGINE TESTING:**

An engine manufactured says in Pune, may ultimately be used in the place where the temperature is low, of the order of 5°C in winter. Such an engine has to be tested under these environmental conditions. Temperature in these testing laboratories at the time of testing may be around 30°C. Hence it will be necessary to artificially cool the intake air to the requisite temperature. At high altitudes both the temperature and the pressure will be low. The engine will have to be tested for cold starting and its power rating. This will again necessitate the creation of suction conditions as obtained at high altitudes [13].

The lubrication system will also have to be turned to the existing conditions. A refrigerating machine is used to cool the lubricating oil to the desired state. A vortex tube is used to attend desired inlet conditions. By operating the hot side valve, the temperature and the pressure can be easily manipulated. A suction pressure stabilizer is required for the steady inlet condition.

Apart from these applications vortex tube can be used to cool electronic and electrical controls, CCTV cameras, soldered parts, gas samples, heat seals, environmental chambers and to set hot melt adhesives [13].

**CONCLUSION**

Vortex tube is a simple device with no moving parts. It separates inlet high pressure stream of air into two lower pressure streams of cooler temperature at one end and hotter temperature at other end. It is basically of counter flow type and parallel flow type. It has many advantages and wide range of applications, mostly using counter flow owing to better performance than parallel flow. Most of the applications reflect the benefits in terms of performance, energy, compactness or as an alternative to the conventional method. Few applications are highlighted in this paper. Variable temperature system uses vortex tube along with liquid nitrogen cooled heat exchanger to maintain lower temperature as the biochemical samples are prone to change properties in unconditioned environment. In case of high speed machining tools, vortex tube cooling improves the performance and tool life along with better finish of work piece. Laser cutting system uses vortex tube cooling to minimize heat affected zone. Vortex air coolers are preferred for different industrial applications. The personal air suit uses vortex tube to allow workers to work under adverse conditions for longer hours. Vortex tube refrigeration is alternative way to the conventional refrigeration in some applications.

**REFERENCES**

- [1] Acar, M. S., and O. Arslan. 2017. "Exergo-economic Evaluation of a New Drying System Boosted by Ranque-Hilsch Vortex Tube." *Applied Thermal Engineering* 124: 1–16. doi:10.1016/j.applthermaleng.2017.06.010.
- [2] Ahlborn, B., J. Camire, and J. U. Keller. 1996. "Low-pressure Vortex Tubes." *Journal of Physics D: Applied Physics* 29: 1469–1472. doi:10.1088/0022-3727/29/6/009.
- [3] Ahlborn, B., and J. M. Gordon. 2000. "The Vortex Tube as a Classic Thermodynamic Refrigeration Cycle." *Journal of Applied Physics* 88 (6): 3645–3653. doi:10.1063/1.1289524.
- [4] Ahlborn, B., J. U. Keller, and E. Rebhan. 1998. "The Heat Pump in a Vortex Tube." *Journal of Non-Equilibrium Thermodynamics* 23 (2): 159–165. doi:10.1515/jnet.1998.23.2.159.
- [5] Ahlborn, B., and S. Groves. 1997. "Secondary Flow in a Vortex Tube." *Fluid Dynamics Research* 21 (2): 73–86. doi:10.1016/S0169-5983(97)00003-8.
- [6] Akhmetov, D. G., T. D. Akhmetov, and V. A. Pavlov. 2018. "Flow Structure in a Ranque–Hilsch Vortex Tube." *Doklady Physics* 63: 235–238. doi:10.1134/S1028335818060010.
- [7] Aljuwayhel, N. F., G. F. Nellis, and S. A. Klein. 2005. "Parametric and Internal Study of the Vortex Tube Using a CFD Model." *International Journal of Refrigeration* 28 (3): 442–450. doi:10.1016/j.ijrefrig.2004.04.004.
- [8] Arbuzov, V. A., Y. N. Dubnishchev, A. V. Lebedev, M. K. Pravdina, and N. I. Yavorskii. 1997. "Observation of Large-scale Hydrodynamic Structures in a Vortex Tube and the Ranque Effect." *Technical Physics Letters* 23 (12): 938–940. doi:10.1134/1.1261939.
- [9] Baz, A., and D. Uhler. 1986. "A Compressed Gas Powered Heating System for Underwater Divers." *Ocean Engineering* 13 (3): 273–290. doi:10.1016/0029-8018(86)90019-3.
- [10] Baz, A., J. Gilheany, and A. Kalvitas. 1987. "Feasibility of Vortex Tube Assisted Environmental Control of an Underwater Research Habitat." *Ocean Engineering* 15 (1): 34–54.
- [11] Baz, A., R. Johnston, and D. Uhler. 1986. "Dynamics of Vortex Tube Assisted Hyperbaric Chambers." *Ocean Engineering* 13 (4): 387–408. doi:10.1016/0029-8018(86)90012-0.
- [12] Bazgir, A. 2019. "Analyzing Separation Capacity Efficiency of A Binary Hydrocarbon System Cyclohexane - N-Pentane with the Help of Two Distinct Methods: Utilizing A Vortex Tube Separator and an Equilibrium Flash Stage (EFS)." *Experimental Thermal and Fluid Science* 109: 109853. doi:10.1016/j.expthermflusci.2019.109853.

- [13] Bazgir, A., M. Khosravi-Nikou, and A. Heydari. 2019. "Numerical CFD Analysis and Experimental Investigation of the Geometric Performance Parameter Influences on the Counter-flow Ranque-Hilsch Vortex Tube (C-RHVT) by Using Optimized Turbulence Model." *Heat Mass Transfer* 55: 2559–2591. doi:10.1007/s00231-019-02578-1.
- [14] Bej, N., and K. P. Sinhamahapatra. 2014. "Exergy Analysis of a Hot Cascade Type Ranque- Hilsch Vortex Tube Using Turbulence Model." *International Journal of Refrigeration* 45: 3–24. doi:10.1016/j.ijrefrig.2014.05.020.
- [15] Bondarenko, V. L., Y. M. Simonenko, and D. P. Tishko. 2020. "Generation of Cold and Heat in Vortex Tubes during Pressure Reduction of Natural Gas." *Chemistry Petrol Engineering* 56: 272–279. doi:10.1007/s10556-020- 00769-w.

