



Performance analysis of 5-Phase Multi-level Inverter Using Carrier Based PWM Technique

¹L.Viswani, ²B.Benkataramana

¹M.Tech Student, ²Associate Professor

¹Electrical and Electronic Engineering Department,

¹Avanathi's St Theresa Institute Of Engineering and Technology, Garividi, Andhrapradesh India.

²Electrical and Electronic Engineering Department,

²Avanathi's St Theresa Institute Of Engineering and Technology, Garividi, Andhrapradesh India.

Abstract

The major analysis has been based on the induction machine drive system that is for the analysis of the carrier based PWM two level source inverter. The unbalanced conditions are mainly to handle the results of simulation for the analysis that results in the two fault conditions. The system setup has been involving the voltage source inverter as well as the five phase multi-level inverter. The effects are through performing the scenarios which consider the performance effects with the load on induction machine. The simulation is based on the imbalance conditions which results on the oscillations depending on the electromagnetic torque through the attendant reduction of the torque rating.

Index Terms— Multilevel inverters, Multiphase machines, Electric vehicles, Existence Function Voltage-source inverter.

I. INTRODUCTION

The multiphase machines have been for handling the electrical generators which set for the phases that is greater than three $n > 3$. The comparison is set under the three phase where the multiphase machines are seen to be greater than the degrees of freedom. The improvement is based on the performance of system with the advantages that is set over the three phase patterns. The system includes the capability with a higher reliable mode and an increment in the power density that has an enhanced fault tolerant capability. [1]-[5]. The extension of the speed capability is to set the reduced frequency or the amplitude that has a pulsating torque. The reduced rotor harmonic currents and the reduced current is mainly to handle the voltage per phase. The multiphase machines are for handling the production of extra torque that will be for the five phase inverter with the harmonics of third, fifth and the seventh range. This could be harnessed with the average torque which directs to adding up for the production that has been done through the current component. The core of the multiphase machine is able to drive the power technology that has been able to produce the different phases through the DC/AC phase of the voltage source. The setup of the system carrier is based on the sinusoidal with pulse width modulation that has been the best technique for the PWM. [2]. The system has been able to implement both the analogue and the digital realisations that have been in the space vector areas.

The intensity of the system has a higher carrier-based modulation which is set in comparison to the higher frequency of the system. The carrier based is to handle the high frequency triangular system with the creation of gating pulses for the power circuit switches. The neutral points are the ac motor drive that are set for the utility purposes and the isolation that is set to interfere in the applications for the neutral current path. The neutral path has been to provide the degree of freedom along with properly determining the duty cycle of the different switch of inverter. The absence is set for handling and determining the duty cycle of the switches of inverter. The potential is to handle the load neutral points as well as the centre points that are to target for the VSI that is called the zero sequence voltage. This can be able to handle any set of values that has been into the modulation of signals and to take hold of the signals through the production of the continuous PWM scheme. The discontinuity is where the potential is based on the phase segments for the positive and the negative systems with the no switch loss. [3]. The intervals are set for the discontinuous modulation with the comparison set to handle the generalised PWM.

The ground system has been covered with the PWM schemes which are for handling the multiphase VSI that has been for using the carrier based PWM or SVPWM. The major focus has been on the implementation of the simulation and analysis of the carrier based analysis. The phase has been to drive and handle the modelling and simulation for the driving of the system. For this, the work has been done and proposed with the extended scheme of the five phase system. The work is mainly for handling the five phase of the VSI drive system and the plot performance that are important for the supplying of the cage induction.

The focus of the paper has been on the applications where there is a multiphase motor drives that will drive to the reduced power demand on the phases where there are two-level multiphase motors that direct to the significant role in cleaning power utility. This helps to handle the deductions of the PWM method with the individual inverter topology along with the generalised approach to save time by properly controlling the novel or hybrid inverter topology. [4]. For the 5-

phase level inverters, the over modulations have been set to control the four level inverter with multiphase multilevel inverter. The major focus has been on handling the principle control between the two limit trajectories that has been for the simple modulation technique and to apply to the converter technology that has been for the higher number of the levels. The sources are set to control and determine the state sequence for the reference voltage vector that vary in a complicated manner. The carrier based PWM is able to set a control for the power converters with over modulation in multiphase inverter. The paper focus on the basic analysis with the under and over modulation range.

II. MULTILEVEL INVERTERS

There are different inverters which are:

a. Diode Clamped multilevel inverter

The major focus has been on handling the multiple voltage levels with the different capacitor banks. The diode transfer is reducing the stress on the electrical device with the diode clamped multilevel inverter. There is a possibility to handle the problems with the increasing of the switch, diode and the capacitors.

b. Flying capacitors multilevel inverter

The major concept has been for connections with clamped switching cells. The clamping diodes are not for the different multilevel inverters. The output is in the half of the DC voltage. The switching redundancy has been within the phase to properly balance the capacitors to control the active and the other power flow. [5].

c. Cascaded H-bridge multilevel inverter.

The cascaded are in the form of handling less components with the topology that has been connecting series of the power cells conversion and holding the easy scaled combination levels.

III. COMPARISION OF FIVE PHASE INVERTER AND DCMLI

Generally hybrid electric vehicles are having single-phase motor for self/quick start and 3-phase IM for internal combustion engine (ICE) separately. The proposed five-phase system is shown in below figure. From the five-phase system, 3-phases are given to 3-phase IM and remaining two phases are given to 1-phase motor (capacitor-start-run) with same supply. For better output and lower THD, 5-level diode clamped multi-level inverter had been used and fed to 3-phase IM and remaining two-phases fed to 1-phase motor which act as full bridge.

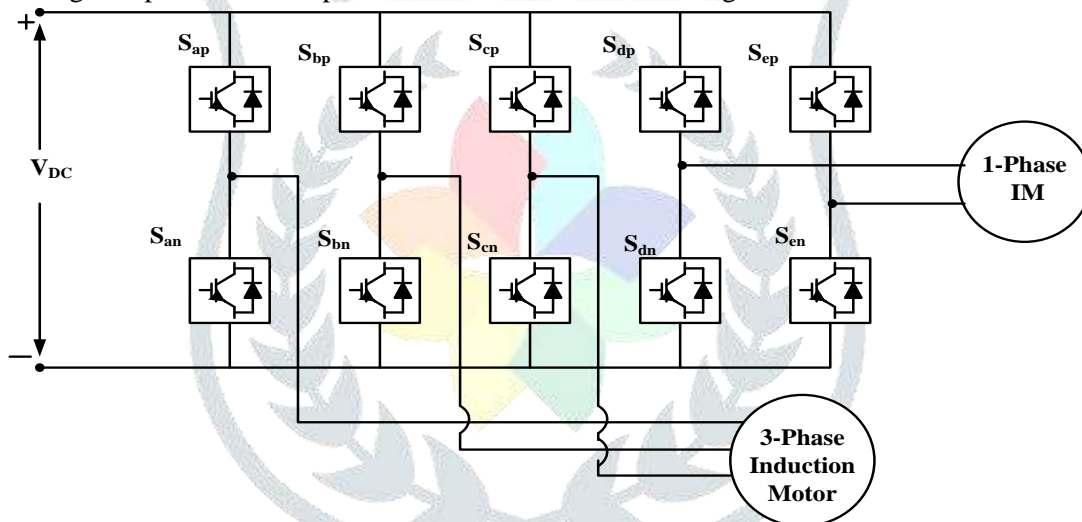

Fig.1. Five phase two-level VSI fed single phase and three phase induction motor.

The below figure 2(a) shows the one phase leg of 5-level Diode Clamped MLI and the figure 2(b) shows the power circuit of single phase bridge voltage source inverter. Here, the semiconductor switch used is IGBT. The ac waveform will generate at the output when the switches s_1s_2 is on and similarly when s_3s_4 is on. The conduction current will flow through the feedback diodes and the energy is fed to the dc source when the semiconductor switch is in off condition.

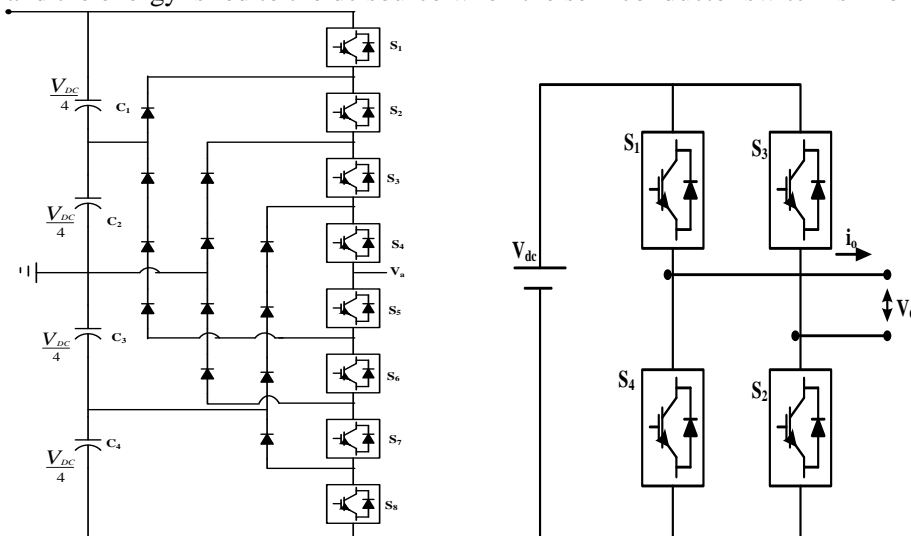

Fig.2(a) shows one phase leg of 5-Level Diode Clamped MLI . (b) Single-Phase Full Bridge Inverter.

IV. CARRIER BASED PWM SCHEME

It The modelling of the carrier based PWM scheme is for handling the three phase VSI that has been applicable for the multiphase VSI. The system has been set to supply the induction machine that is:

$$v_{js} = L_{js}p i_{js} + r_{js} i_{js} \quad (1)$$

Here, the focus has been on the phase to neutral output voltage from the VSI with the phase currents and the induction machine stator inductance. [7].

There have been turn-on and turn-off for the handling of the existence functions. These are important for setting the unity value with the switching device that is turned on and off. The functions have been set to voltage. connect and represent the top and bottom device. The switching possibilities are set as per the options of carrier based system with the two modes linear modulation and the nonlinear modulation. The linear modulation has been with the peak of the modulations which is less or equal to the peak of the signal values. The operations have been to handle the ratio that is for line-to-neutral phase inverter output. [8].

VI. DETERMINATION OF THE AVERAGE NEUTRAL VOLTAGE

The carrier based scheme has been important for the topology which needs less carriers for handling the conventional multilevel inverters. These are for holding the generation of gate pulses for a higher frequency of the switches and the three carrier waves which are set in comparison to the different reference waves of sinusoidal.

Considering the average neutral voltage, there have been functions which are set to handle the higher value ranges for the -1 and 1. The implementation is set to work over on the higher positive peak and negative peak values. The attributes of modulation depends on handling the corresponding models of the signal modulation with the generation of the switching functions. The responsible production is based on the zero sequence signal which will be able to synthesise and work on the triangle carrier signals. [9],[11]. The system products and the linearity is based on the common node voltage with the representation over the instantaneous minimum and the maximum magnitudes of the reference for the modulating voltage.[11].

$$v_{no} = 0.5v_{dc}(1 - 2\alpha) - \alpha v_{min} + (\alpha - 1)v_{max} \quad (2)$$

The determination of the common node zero sequence is set for the system that will not be mainly for balancing the load. There is adaption of the five phase system for the rearrangement of:

$$v_{jo} = v_{jn}^* + v_{mo}^* \quad (3)$$

VII. SIMULATION RESULT – APPENDIX

The results have been for modelling the 5 phase inverter fed single phase and three phase induction machines used in EV applications which has been developed using the SimuLink. The analysis is based on encompassing with the injection of common zero sequence with the implementation of the balanced and the unbalanced load. The prototype machine is based on handling the peak voltage with the nine phase machine of the 60V.

Table 1

Parameter	Value
Rated power	3hp
Stator Resistance(R_s)	2.9 Ω
Referred Rotor Resistance(R_r')	2.2 Ω
Mutual Inductance(L_m)	0.03458H
Stator Leakage Inductance(L_{ls})	0.0599mH
Referred Rotor Leakage Inductance(L_{lr}')	0.0599mH
Number of Poles	4
Moment of Inertia(J)	0.05kg-m ²

As per the analysis, the output voltage for the two different types of the inverters are through the sim power system which is able to handle the blocking sets for the Simulink software. The inbuilt functional blocks are mainly for the use of the simulator. The inverter technologies have been mainly for handling the harmonic distortions with the speed and the torque curve. These are mainly for the balance that has been set through the five phase inverter. five phase inverter.

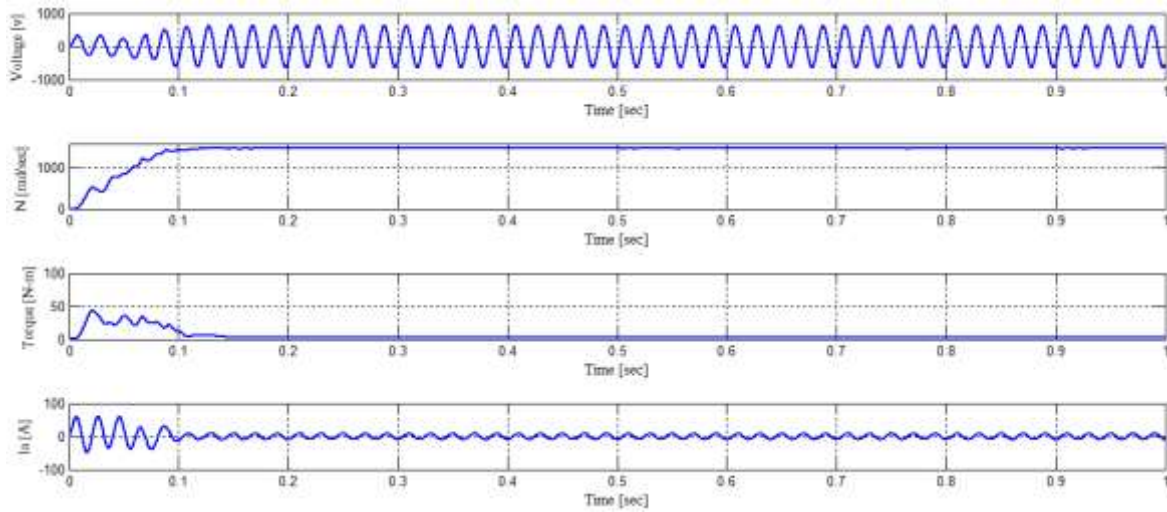

Fig.4.Single phase Induction Motor Voltage Capacitor, Speed, Torque and Winding Current.

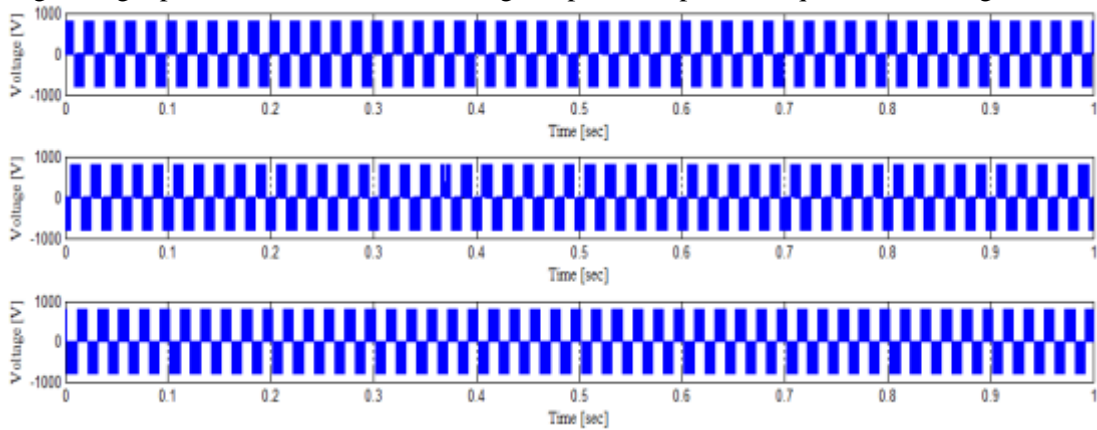

Fig.5.Two-level voltage source inverter line to line voltage.

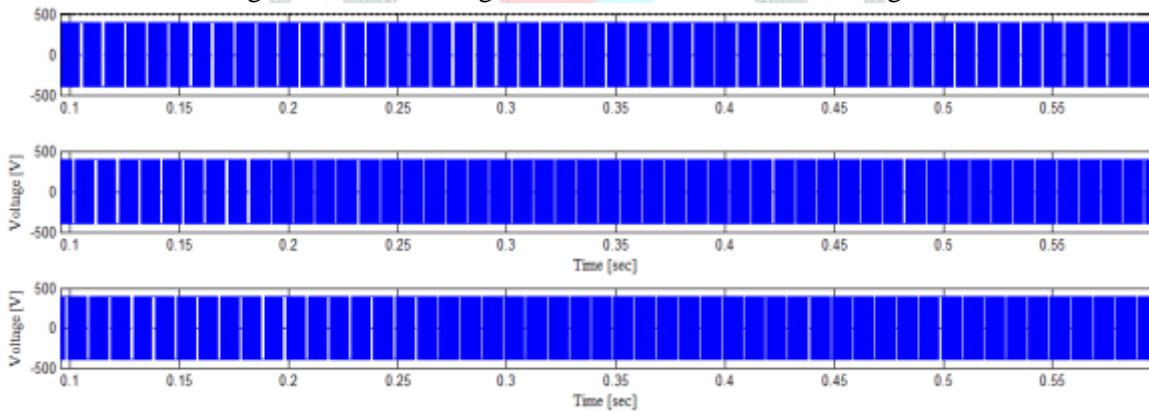

Fig.6.Two-level voltage source inverter phase to phase voltage.

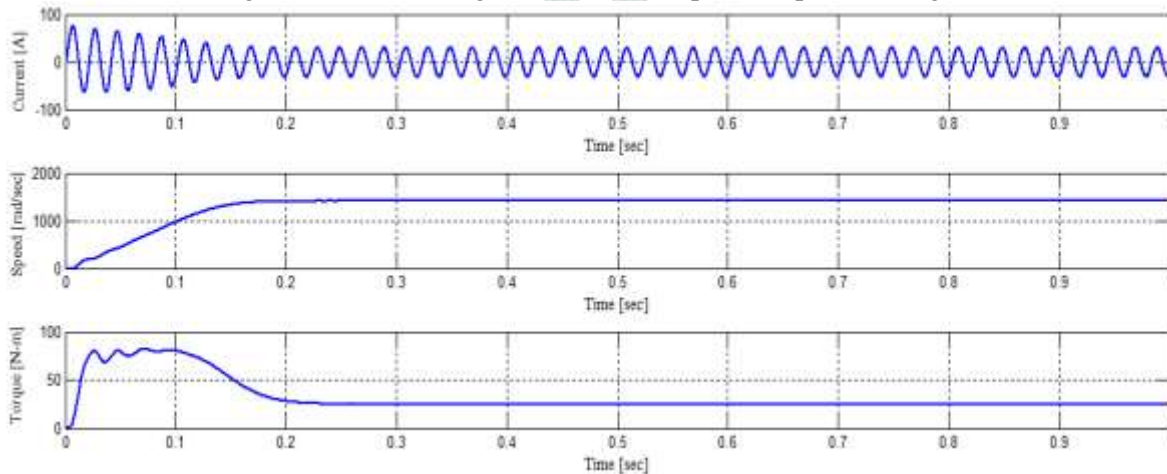

Fig.7.Three phase Induction Motor Current, Speed and Torque.

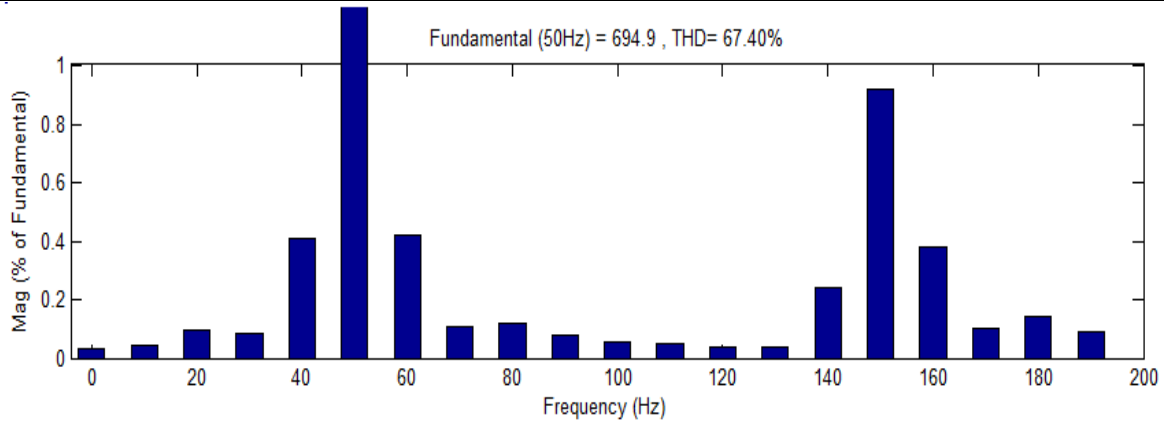

Fig.8. FFT Analysis of 5-phase 2-level inverter

The following are the results for Matlab/Simulink Model of Five-phase Five-Level Inverter and the THD had been reduced by 50% from 67.40% to 17.72% respectively.

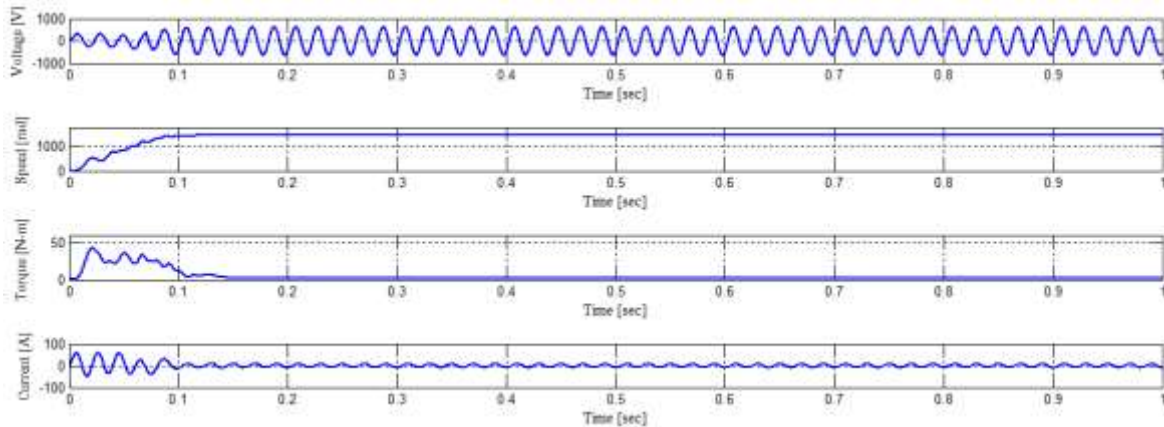

Fig.9.Single phase Induction Motor Voltage Capacitor, Speed, Torque and Winding Current.

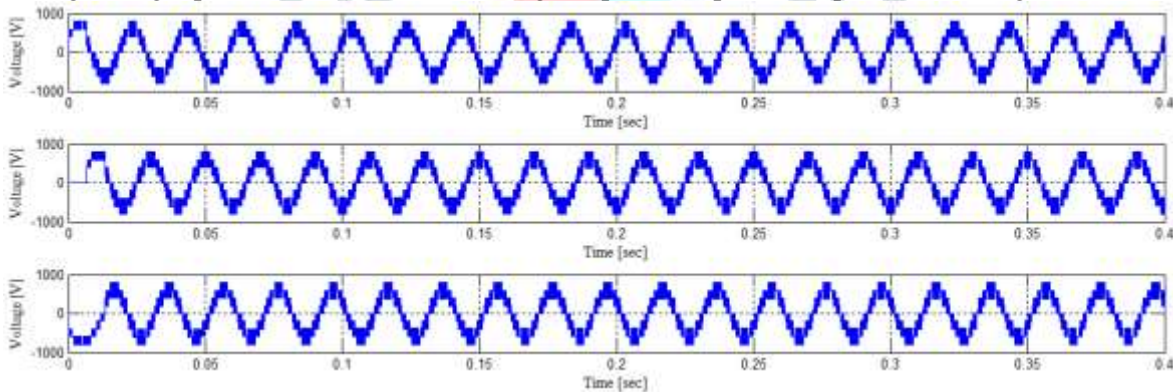

Fig.10.Five-Level Inverter line to line Voltage.

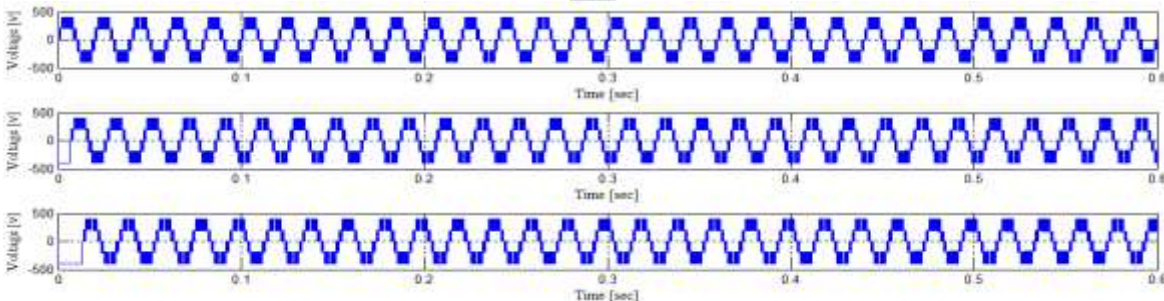

Fig.11.Five-level Inverter phase to phase Voltage.

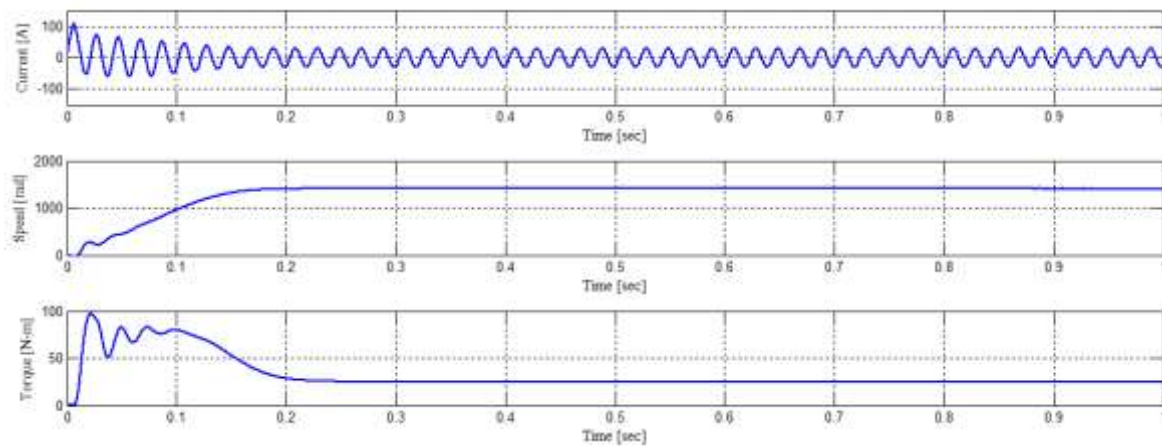

Fig.12 Three-phase Induction Motor Current, Speed and Torque.

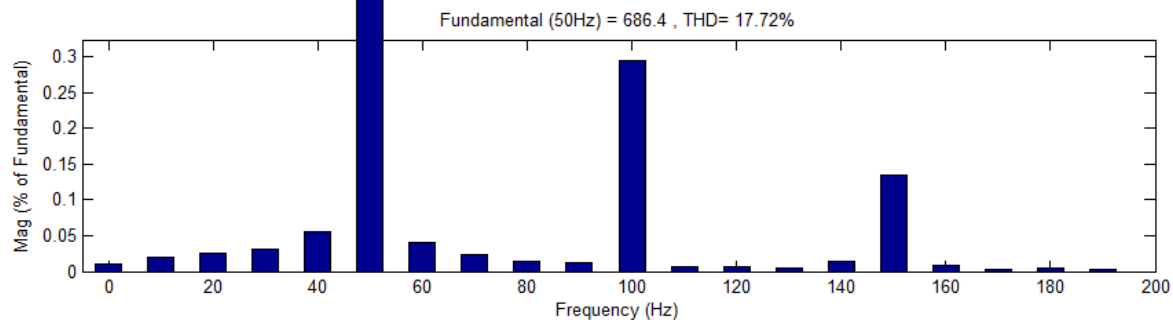

Fig.13.FFT analysis of 5-phase 5-level inverter

VIII. CONCLUSION

The carrier based PWM has been for the setting of two level source of voltage that has been for the development process. There have been a detailed process for the simulation that directs to settle the balance in the modulation signal. The carrier based VSI has been for handling the VSI results which are for handling the involvement of the modulation signals and the load. There have been oscillations for the normal inverter and the machine operations with the dropping of the rotor speed and the application that set the two imbalance. [10]. The paper has been set to design the signals with the SPWM control that has been presented with the waveforms in Simulink. The system structure and the modulation index is based on the measurement results that have been designed as per the phase shifts. The output has been in the linear modulation band with the effective process of the harmonic content.

REFERENCES

- [1] X. S. Li, *et al.*, "Analysis and Simplification of Three-Dimensional Space Vector PWM for Three-Phase Four-Leg Inverters," *IEEE Transactions on Industrial Electronics*, vol. 58, pp. 450-464, Feb 2011.
- [2] R. Arulmozhiyal and K. Baskaran, "Implementation of a Fuzzy PI Controller for Speed Control of Induction Motors Using FPGA," *Journal of Power Electronics*, vol. 10, pp. 65-71, 2010.
- [3] N.V. Nho and N.X. Bac, "Carrier Pwm Control Of Cascaded Hybrid NPC3-Level Inverter And Two-Level Inverters", Intl. Symposium on Electrical & Electronics Engineering, 2007, pp. 59-65.
- [4] J.Rodriguez, P. Hammond, J. Pont and R.Musalem, "Method to increase reliability in 5-level inverter," *Electronics letters*, Vol.39, Issue 18, pp.1343-1345, 4 Sept. 2003.
- [5] A. M. Massoud, S. J. Finney and B. W. Williams, "Control techniques for Multilevel voltage source inverters," *IEEE 34th Annual Power Eletronics Specialist Conference PESC '03*, Vol. 1, pp. 171-176, 15-19 June 2003.
- [6] B. Jian-yu, L. Yu-ling and Z.Z. Chao, "a 6-switch single-phase 5-level current-source inverter," *Zhejiang University Press co-published with Springer-Verlag GMBH*, Vol. 7, No. 6, pp 1051-1055, June 2006.
- [7] Gui-Jia Su, "Multilevel DC-link inverter," *IEEE Transactions on Industry Applications*, vol.41, No. 3, pp 848-854, May-June 2005.
- [8] Panagis, F. Stergiopoulos, P. Marabeas and S. Manias, "Comparision of state of the art multilevel inverters," *IEEE Annual Power Eletronics Specialist Conference PESC '08*, pp. 4296-4301, 15-19 June 2008.
- [9] B.R. Lin, "A novel control scheme for the multilevel rectifier/inverter," *Taylor and Francis International Journal of Electronics*, Vol. 88, No. 2, pp. 225-247, February 2001.
- [10] J. I. Leon, R. Portillo, S. Vazquez, J. J. Padilla, L. G. Franquelo and J. M. Carrasco, "Simple unified approach to develop a time-domain modulation strategy for single-phase multilevel converters," *IEEE Transactions on Industrial Electronics*, Vol. 55, No. 9, pp. 3239-3248, Sept. 2008.