



## COMPARISON OF CONVENTIONAL SINGLE PHASE 21-LEVEL CASCADED H-BRIDGE MULTILEVEL INVERTER AND SINGLE PHASE 21 LEVEL MULTILEVEL INVERTER WITH REDUCED SWITCHES AND SOURCES FOR RENEWABLE ENERGY APPLICATIONS

<sup>1</sup> Abhijeet Anand Aiwale

, <sup>2</sup> Dr. Sanjay G. Kanade

, <sup>3</sup> Dr. Ashish P. Kinge

<sup>1</sup>Student <sup>2</sup>Professor, <sup>3</sup>Head of Department

<sup>1</sup>Electrical Power System,

<sup>1</sup>Bhivarabai Sawant college of Engineering and Research, Narhe, Pune, India

**Abstract :** Multilevel Inverters are influencing many industries because of their applications in renewable energy with low switching losses, low THD and high dv/dt stress. In this paper, conventional single phase 21 level cascaded H-bridge multilevel inverter and single phase 21 level multilevel inverter with reduced switches and sources have been compared. Here, a conventional single phase 21 level cascaded H-bridge multilevel inverter and 21 level multilevel inverter with reduced switches and sources, the switching angles and the corresponding time required to generate the gating pulses of IGBT switches of both multilevel inverters is calculated by Equal Phase (EP) Method. The conventional single phase 21 level cascaded H-bridge MLI with 40 IGBT switches and 10 separate DC sources whereas multilevel inverter with reduced switches and sources require only 8 IGBT switches and 4 separate DC sources to obtain 21 level output voltage. Since, in case of 21 level multilevel inverter with reduced switches and sources, the number of switches are less, the cost is less and the circuitry is simple. The simulation results of both were presented using MATLAB/SIMULINK

**IndexTerms** - Multilevel Inverter (MLI), Equal Phase(EP), Separate DC Sources (SDCS), Total Harmonic Distortion (THD).

### I. INTRODUCTION

Multilevel inverters continue to receive more and more attention because of their high voltage operation capability, low switching losses, high efficiency and low Total Harmonic Distortion (THD). The term multilevel starts with the three-level inverter introduced by Nabae et al (1981). Nowadays, multilevel inverters are becoming increasingly popular in power applications, as multilevel inverters have the ability to meet the increasing demand of power rating and power quality associated with reduced harmonic distortion and lower electromagnetic interference.

There are different types of inverter topologies available in which some are popular. Different types of MLI are Diode Clamped MLI, Flying capacitor type MLI and Cascaded H-Bridge multilevel inverter and that is very popular among all the topologies. In this paper, conventional single phase 21 level Cascaded H-Bridge Multilevel Inverter and single phase 21 level multilevel inverter with reduced switches and sources have been compared. The output voltage results were simulated and presented in this paper[1][2].

Also, Switching angles of both multilevel inverters can be calculated by following methods:-

- Equal Phase (EP) Method.
- Half Equal Phase (HEP) Method.
- Half Height (HH) Method.
- Feed Forward (FF) Method.

In this paper switching angles of both a conventional single phase 21 level cascaded H-bridge multilevel inverter and single phase 21 level multilevel inverter with reduced switch and sources have been calculated by using Equal phase method. Finally, these two topologies have been compared and corresponding work has been embodied as follows.

## II. CONVENTIONAL SINGLE PHASE 21 LEVEL CASCADED H-BRIDGE MULTILEVEL INVERTER

As the name suggest, conventional single phase cascaded H-bridge multilevel inverter is constructed by a series of H- bridge inverter in cascade configuration. This type of topology is a conventional configuration structure. The topology proposes a concept with a use of separate DC sources connected to each H-bridge to generate a sinusoidal voltage. The final ac output voltage is produced by cascading the individual H-bridge voltage outputs[3].

Figure 2.1 illustrates a generalized block diagram of Conventional Single Phase  $m$ -level Cascaded H-bridge Multilevel Inverter. In this case, 21 different voltage output levels were generated for each inverter level with an appropriate control scheme of the switches. The output waveform is generated as according to the switching table given below in the table. The sum of different individual H-bridge inverter outputs connected in series synthesized the final sinusoidal output voltage of the multilevel inverter. An equation  $m=2s+1$  determine the number of voltage levels 'm' in a conventional single phase 21 level cascaded H-bridge inverter where 's' is the number of independent DC source connected to the individual H-bridge inverter. Thus there were 10 separate DC sources used in this topology. The final output voltage  $V_{a[(m-1)/2]}$  is a sum of all individual voltage values of H-bridges connected in cascade. The simulink result of voltage output is shown in Figure 2.2. Also THD analysis of conventional single phase 21 Level cascaded H-bridge MLI is shown in figure 3.1. by FFT analysis with the aid of MATLAB/SIMULINK[4].

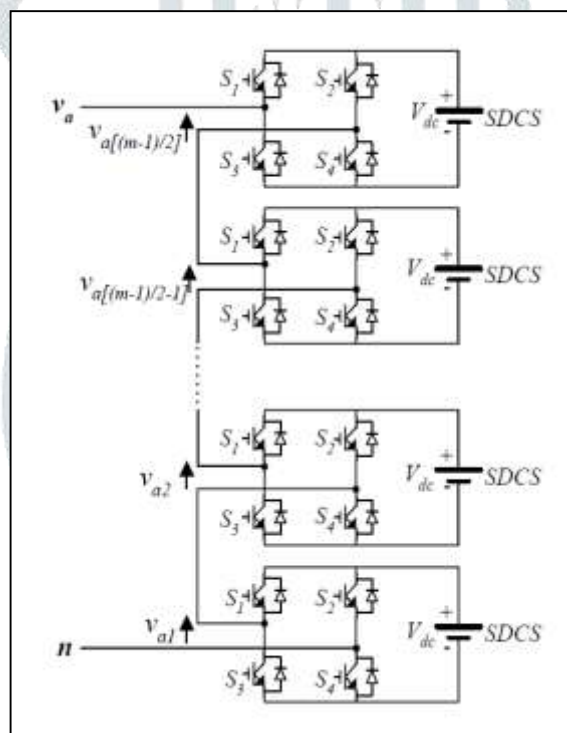


Figure 2.1- Generalized block diagram of Conventional Single Phase  $m$ -level Cascaded H-bridge Multilevel Inverter

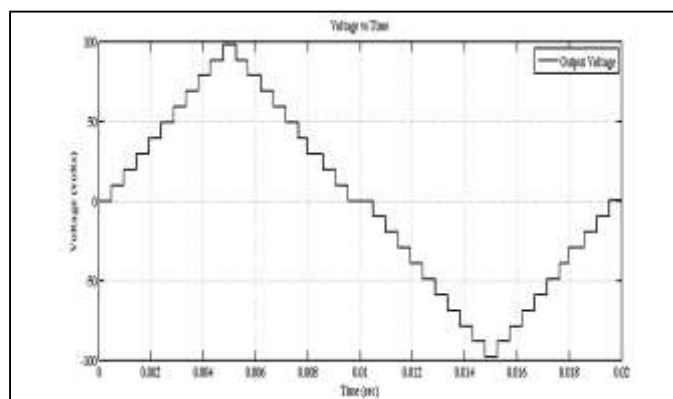


Figure 2.2 - Voltage output of conventional single phase 21 level cascaded H-Bridge MLI by EP method

VOLTAGE LEVEL	NUMBERS OF ON SWITCHES
$10 V_{dc}$	1,2,6,10,14,18,22,26,30,34,37,38
$9 V_{dc}$	1,2,6,10,14,18,22,26,30,33,34,38
$8 V_{dc}$	1,2,6,10,14,18,22,26,29,30,34,38
$7 V_{dc}$	1,2,6,10,14,18,22,25,26,30,34,38
$6 V_{dc}$	1,2,6,10,14,18,21,22,26,30,34,38
$5 V_{dc}$	1,2,6,10,14,17,18,22,26,30,34,38
$4 V_{dc}$	1,2,6,10,13,14,18,22,26,30,34,38
$3 V_{dc}$	1,2,6,9,10,14,18,22,26,30,34,38
$2 V_{dc}$	1,2,5,6,10,14,18,22,26,30,34,38
$1 V_{dc}$	1,2,6,10,14,18,22,26,30,34,38
0	
$-1 V_{dc}$	4,8,12,16,20,24,28,32,36,39,40
$-2 V_{dc}$	4,8,12,16,20,24,28,32,35,36,39,40
$-3 V_{dc}$	4,8,12,16,20,24,28,31,32,36,39,40
$-4 V_{dc}$	4,8,12,16,20,24,27,28,32,36,39,40
$-5 V_{dc}$	4,8,12,16,20,23,24,28,32,36,39,40
$-6 V_{dc}$	4,8,12,16,19,20,24,28,32,36,39,40
$-7 V_{dc}$	4,8,12,15,16,20,24,28,32,36,39,40
$-8 V_{dc}$	4,8,11,12,16,20,24,28,32,36,39,40
$-9 V_{dc}$	4,7,8,12,16,20,24,28,32,36,39,40
$-10 V_{dc}$	3,4,8,12,16,20,24,28,32,36,39,40

### III. CALCULATION OF SWITCHING ANGLES

The several methods of estimating the switching angle have been proposed. In this paper, Equal phase (EP) method is considered for calculation of switching angles for both a conventional single phase 21-level cascaded H-bridge multilevel inverter as well as single phase 21 level multilevel inverter with reduced switch and sources[5].

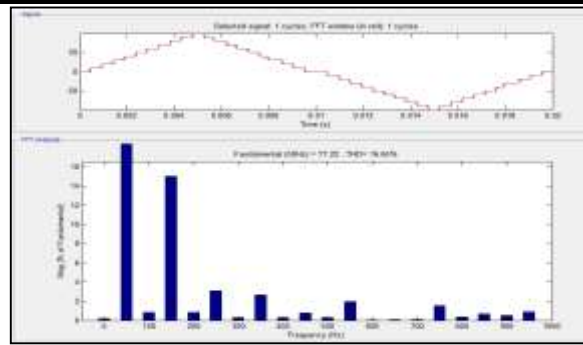
#### Equal Phase Method

In this method, the estimation of switching angles were performed by the equation (3.1),

$$\alpha_i = i * \left(\frac{180}{m}\right) \quad (3.1) \quad \text{Where, } i = 1, 2, 3, 4, \dots, \frac{(m-1)}{2}, \text{ and}$$

'm' is number of output level. These switching angles are distributed averagely over the range 0 – 180 degree.

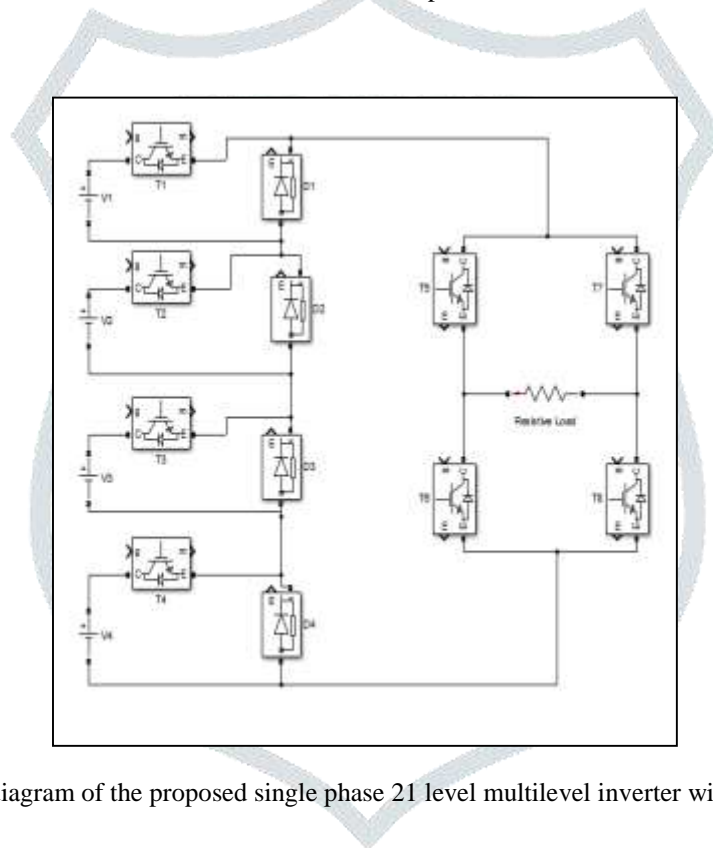
The switching table of conventional single phase 21 level cascaded H- bridge MLI is illustrated in Table 2.1. The switching angles(by EP method) and corresponding PWM inputs were given to both conventional single phase 21 level cascaded H-bridge MLI as well as 21 level MLI with reduced switches and sources. Figure 2.2 shows the voltage output conventional single phase 21-level cascaded H- bridge MLI obtained from Equal Phase method. The harmonic spectrum for the conventional single phase 21 level cascaded H-bridge multilevel inverter output voltage has been computed with the help of Fast Fourier Transform function (FFT) in MATLAB Simulink[6].



**Figure 3.1-** THD and FFT analysis of conventional single phase 21 Level Cascaded H-Bridge MLI

#### IV. PROPOSED 21 LEVEL MULTILEVEL INVERTER WITH REDUCED SWITCHES AND SOURCES

The advantages of the DTC is to eliminate the direct and Figure 4.1 shows the circuit diagram of the proposed 21 level multilevel Inverter with reduced switches and sources. In this, 8 IGBT switches, 4 separate DC sources and 8 power diodes were used[7]. The working principle of this inverter is described with the help of Table 4.1.



**Figure 4.1-** The circuit diagram of the proposed single phase 21 level multilevel inverter with reduced switches and sources

#### V. MODES OF OPERATIONS:

- Mode 1: In this mode, when switches T1, T2, T3, T4, T5, T6, T7, T8 are turned “off”, the output voltage will be ‘0’.
- Mode 2: When switches T1, T5, T8 are turned “on”, the output voltage across the load will be ‘V1’.
- Mode 3: When switches T2, T5, T8 are turned “on”, the output voltage will be ‘V2’.
- Mode 4: When switches T3, T5, T8 are turned “on”, the output voltage will be ‘V3’.
- Mode 5: when switches T4, T5, T8 are turned “on”, the output voltage across the load will be ‘V4’.
- Mode 6: When switches T1, T4, T5, T8 are turned “on”, the output voltage will be ‘V1+V4’.
- Mode 7: When switches T2, T4, T5, T8 are turned “on”, the output voltage will be ‘V2+V4’.
- Mode 8: When switches T3, T4, T5, T8 are turned “on”, the output voltage will be ‘V3+V4’.
- Mode 9: When switches T1, T3, T4, T5, T8 are turned “on”, the output voltage across the load will be ‘V1+V3+V4’.
- Mode 10: When switches T2, T3, T4, T5, T8 are turned “on”, the output voltage will be ‘V2+V3+V4’.
- Mode 11: When switches T1, T2, T3, T4, T5, T8 are turned “on”, the output voltage will be ‘V1+V2+V3+V4’.
- Mode 12: When switches T1, T6, T7 are turned “on”, the output voltage across the load will be ‘-V1’.
- Mode 13: When switches T2, T6, T7 are turned “on”, the output voltage will be ‘-V2’.
- Mode 14: When switches T3, T6, T7 are turned “on”, the output voltage will be ‘-V3’.
- Mode 15: when switches T4, T6, T7 are turned “on”, the output voltage across the load will be ‘-V4’.
- Mode 16: When switches T1, T4, T6, T7 are turned “on”, the output voltage will be ‘-V1-V4’.

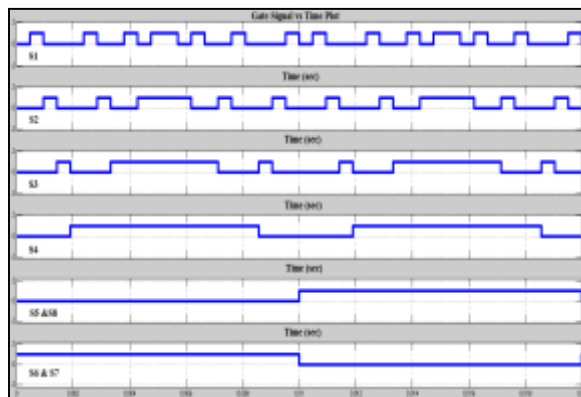
- Mode 17: When switches T2, T4, T6, T7 are turned “on”, the output voltage will be ‘-V2-V4’.
- Mode 18: When switches T3, T4, T6, T7 are turned “on”, the output voltage will be ‘-V3-V4’.
- Mode 19: When switches T1, T3, T4, T6, T7 are turned “on”, the output voltage across the load will be ‘-V1-V3-V4’.
- Mode 20: When switches T2, T3, T4, T6, T7 are turned “on”, the output voltage will be ‘-V2-V3-V4’.
- Mode 21: When switches T1, T2, T3, T4, T5, T8 are turned “on”, the output voltage will be ‘-V1-V2-V3-V4’.

Output voltage	T1	T2	T3	T4	T5	T6	T7	T8
V1+V2+V3+V4	1	1	1	1	1	0	0	1
V2+V3+V4	0	1	1	1	1	0	0	1
V1+V3+V4	1	0	1	1	1	0	0	1
V3+V4	0	0	1	1	1	0	0	1
V2+V4	0	1	0	1	1	0	0	1
V1+V4	1	0	0	1	1	0	0	1
V4	0	0	0	1	1	0	0	1
V3	0	0	1	0	1	0	0	1
V2	0	1	0	0	1	0	0	1
V1	1	0	0	0	1	0	0	1
0	0	0	0	0	0	0	0	0

**Table 5.1** -The all positive level switching states of single phase 21 level MLI with reduced switches and sources with corresponding voltage levels.

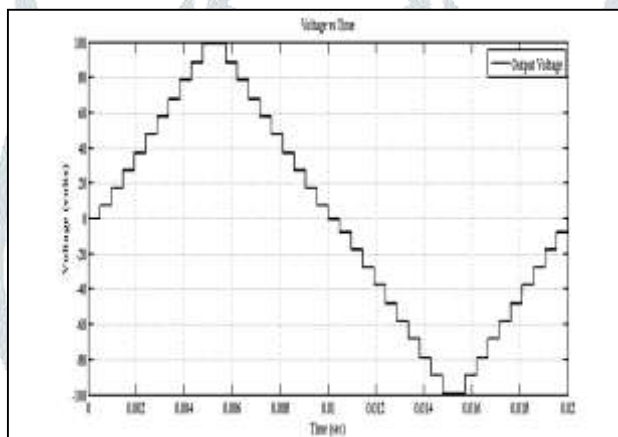
**VI. SWITCHING PULSE PATTERN BY EQUAL PHASE METHOD FOR SINGLE PHASE 21 LEVEL MLI WITH REDUCED SWITCHES AND SOURCES**

Equal Phase Method for calculation of switching angle gives better output voltage. The switching pulses obtained through Equal Pulse Method is illustrated in Figure 6.1.

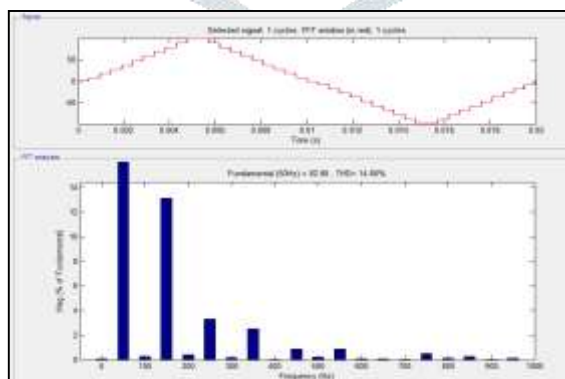


**Figure 6.1-** The switching pulses obtained through Equal Pulse Method

Figure 5.2, shows voltage output for the proposed single phase 21-level MLI with reduced switches and sources obtained from Equal Phase method. The harmonic spectrum for the proposed inverter output voltage has been computed with the help of Fast Fourier Transform function (FFT) in MATLAB/ SIMULINK.



**Figure 6.2 -** Voltage output waveform of proposed single phase 21 level MLI with reduced switches and sources by EP method



**Figure 6.3 -** THD analysis of proposed single phase 21 level MLI with reduced switches and sources by EP method

COMPARISONA brief study which is based on the number of switches, diodes, sources of proposed topology with conventional topology for 21 level voltage output is carried out. The results are given in Table 6.1. From this table, it is clear that the proposed Multilevel Inverter requires a lesser number of switches and voltage sources to achieve the required output voltage

	PARAMETER	CASCADED CONVENTIONAL MLI	REDUCED SWITCHES AND SOURCES MLI
1.	Number of Levels	21	21
2.	No. of DC Sources	10	4
3.	No. of Switches	40	8
4.	THD	16.65%	14.66%
5.	Cost	More	Less

Table 6.1- Comparison of MLIs

THD Analysis

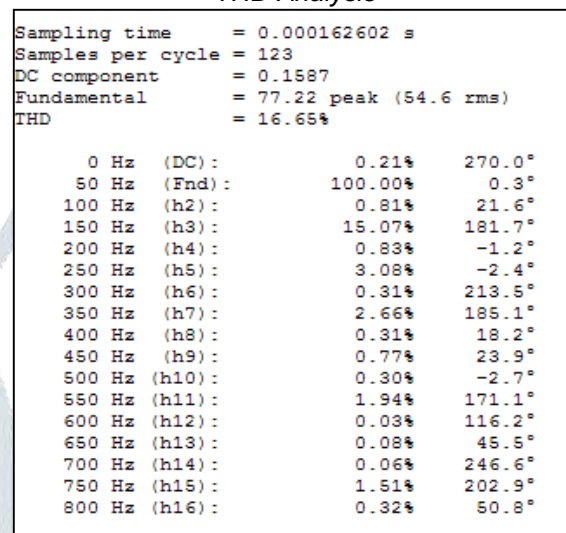


Figure 6.4- Harmonic analysis of conventional single phase 21 Level Cascaded H-Bridge MLI

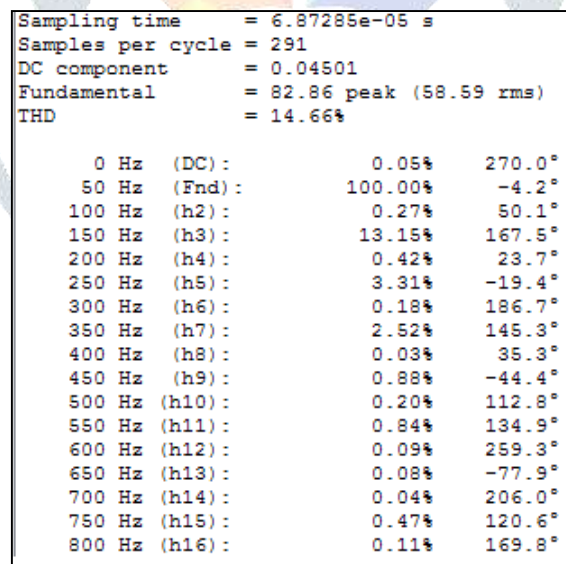


FIGURE 6.5 - HARMONIC ANALYSIS OF SINGLE PHASE 21 LEVEL MLI WITH REDUCED SWITCHES AND SOURCES

VII. CONCLUSION

The proposed single phase 21 level multilevel inverter with reduced switches and sources offers minimum switching devices and minimum separate DC sources for generating 21 level output voltage. The results of the proposed MLI comes in diminished size, lesser loss, along with low installation cost. In addition, THD in the output voltage of the proposed single phase 21 level MLI with reduced switches and sources is low. Therefore, it is reasonable for medium and high-power applications. The calculation of switching angles was obtained through Equal Phase Method. The simulation result showed that the Equal Phase method offers less THD compared with normal pulse generator input. Besides, Equal Phase Method achieves high RMS output voltage. Future work can be performed having made a 31-level inverter from the same circuit.

## VIII. REFERENCE

- [1] M. bin Arif, S. Ayob, A. Iqbal, S. Williamson and Z. Salam, "Ninelevel asymmetrical single phase multilevel inverter topology with low switching frequency and reduce device counts", *2017 IEEE International Conference on Industrial Technology (ICIT)*, 2017.
- [2] Aditay Vardhan Singh, Ravi Shankar Singh, "A Comparative Study of Multilevel Inverter Topologies" *IRJET*, Volume: 05 Issue: 03 | Mar-2018
- [3] V. Devi and S. Srivani, "Modified phase shifted PWM for cascaded H bridge multilevel inverter", *2017 Third International Conference on Advances in Electrical, Electronics, Information, Communication and Bio-Informatics (AEEICB)*, 2017.
- [4] Ehsan Najafi, *Member, IEEE*, and Abdul Halim Mohamed Yatim, *Senior Member, IEEE*, "Design and Implementation of a New Multilevel Inverter Topology ",*IEEE TRANSACTIONS ON INDUSTRIAL ELECTRONICS*, VOL. 59, NO. 11, NOVEMBER 2012
- [5] N. Agrawal and P. Bansal, "A new 21-level asymmetrical multilevel inverter topology with different PWM techniques", *2017 Recent Developments in Control, Automation & Power Engineering (RDCAPE)*, 2017.
- [6] Aparna Prayag, Sanjay Bodkhe, "A Comparative Study of Symmetrical and Asymmetrical Cascaded H Bridge Multilevel Inverter Topology for Industrial Drive." *IRJET*, Volume: 05 Issue: 02 | Feb-2018.
- [7] Md. Tariqul Islam, Md. Shahidul Islam and Arnob Kumar Bairagi, "A New Single Phase 21 Level Inverter Topology with Reduced Number of Switches and Sources for Renewable Energy Applications", *4th International conference on Electrical Engineering and information and communication technology*.

