

A Novel Implementation of E-Bicycle

Dhuvala Pranusha¹

Assistant Professor, Department of Electrical and Electronics Engineering, Vignan Institute of Technology and Science, Telangana.

D.Nikhitha²

M.Shashank³

k.Likhil⁴

Shaik Dawood ashiq⁵

U.G. Student, Department of Electrical and Electronics Engineering, Vignan Institute of Technology and science, Telangana.

ABSTRACT

The main aim of this review paper is to present the idea of harnessing the various energy and use it in today's existence of human life. Now-a-days there are so many vehicles on road, which consumes more fuel and also hazards our environment. It is our responsibility to reduce the consumption of fuel and its hazardous emission products. Taking this into consideration it is our small step towards reducing the use of more fuel consuming vehicles and attract the eye of people towards its alternatives i.e. Electric bicycle. So we intend to design a cycle which would run on an alternative source and also reducing human efforts called as Battery Operated Cycle. In this paper we design an alternative mode of transport for betterment of social and environment.

INTRODUCTION

The electric bicycle is an electrical-assisted device that is designed to deliver the electromagnetic momentums to a present bicycle therefore relieving the user of producing the energy essential to run the bicycle. It contains a strong motor and enough battery power that just needs charging to help in hill climbing, generate greater motoring speeds and provide completely free electric transportation. Electric vehicles price more and perform poorer than their gasoline counterparts. The aim is that mainly because gasoline cars have promoted from a century of intensive development; electric cars have been virtually overlooked for several years. Even today,

gasoline cars profit from billions of dollars of research every year while electric vehicles receive a small fraction of that quantity of money. The primary principle for the Universities' support of the electric powered over the petrol powered has been towards improving air quality, though air quality alone is not a satisfactory justification to mandate electric bicycles. The single biggest advantage of electric bicycle is that it is cost operative as it mainly only entails building cost as running cost would only require the charging of the battery. An Electric bicycle would, however offer other solid benefits that are overlooked by the marketplace. These include the intense reduction in oil consumption that its widespread use would bring about. Much less oil would be needed because only a tiny proportion of electricity is generated from oil. The further major non-market benefit would be lower greenhouse gas emissions

METHODOLOGY

With our guide support and our technical knowledge and interest on the electrical vehicles and the electrical motors we choose to develop and design this project of electrical bike. By referring to these journal paper we came up with an idea of E-bike kit. Design of E-bike: before we design the vehicle we did many calculations based on the speed of the vehicle based on the speed and motor rating, battery rating, charging capacity of the bike, and weight of the bike and the amount of the weight bike can run. Calculations on E-bike components for the E-bike like DC Motor, Motor controller and Battery. Based on the requirement of capacity and range. Fabrication: By installing the electric motor to the rear wheel we designed a mounting plate which allowed the motor to the

mounted on the rear axle. Then we designed and fabricated a battery container with shock absorbing material to keep the battery safe from vibration. Testing: After the completion of E-bike various tests were carried out on the E-bike like speed of e-bike in kmph, range of e-bike

(distance travelled by E-bike on full charge) and load carrying capacity

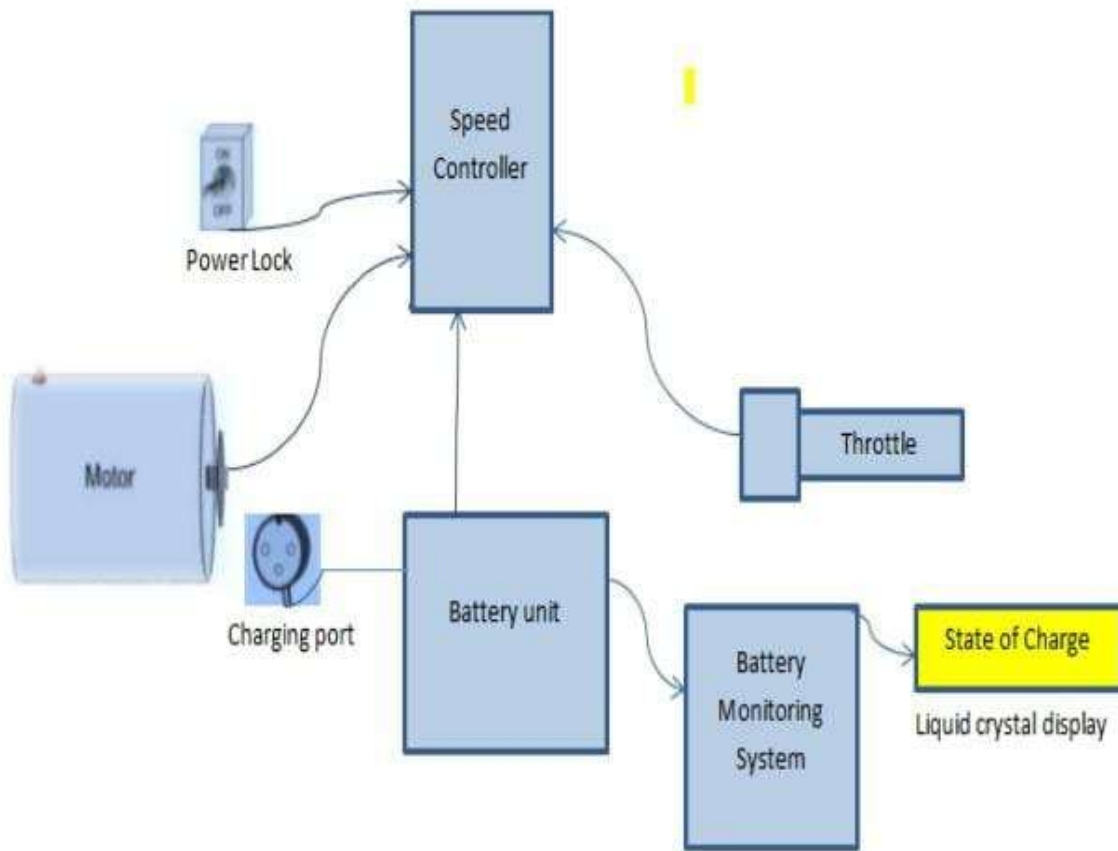

Figure 1 Block diagram of total body of E-Bicycle

ADVANTAGES

- Deployable batteries can be taken inside house.
- Cost of unit is low.
- Easy to carry since it is portable.
- Less energy consumed.
- High efficiency can be obtained if inverter is used.
- If using solar free utilization of energy can be done.

DISADVANTAGES

- Less speed range
- Limited weight.

RESULT

The project “**E-Bicycle**” was designed such that to design a system which helps future of automobiles will

be mostly of electrical and electronics this would help in such way. While the market abounds in motorbikes, electric bikes will soon be the mode of communication for almost every household. Thus the cost of the fuel and the economical affects that are being faced can be reduced .Electric bike is quite ecofriendly and it can bring a huge development to the society in the future here in our project the charging is being the major drawback and the alternate source can be found and it will be rectified as soon as possible

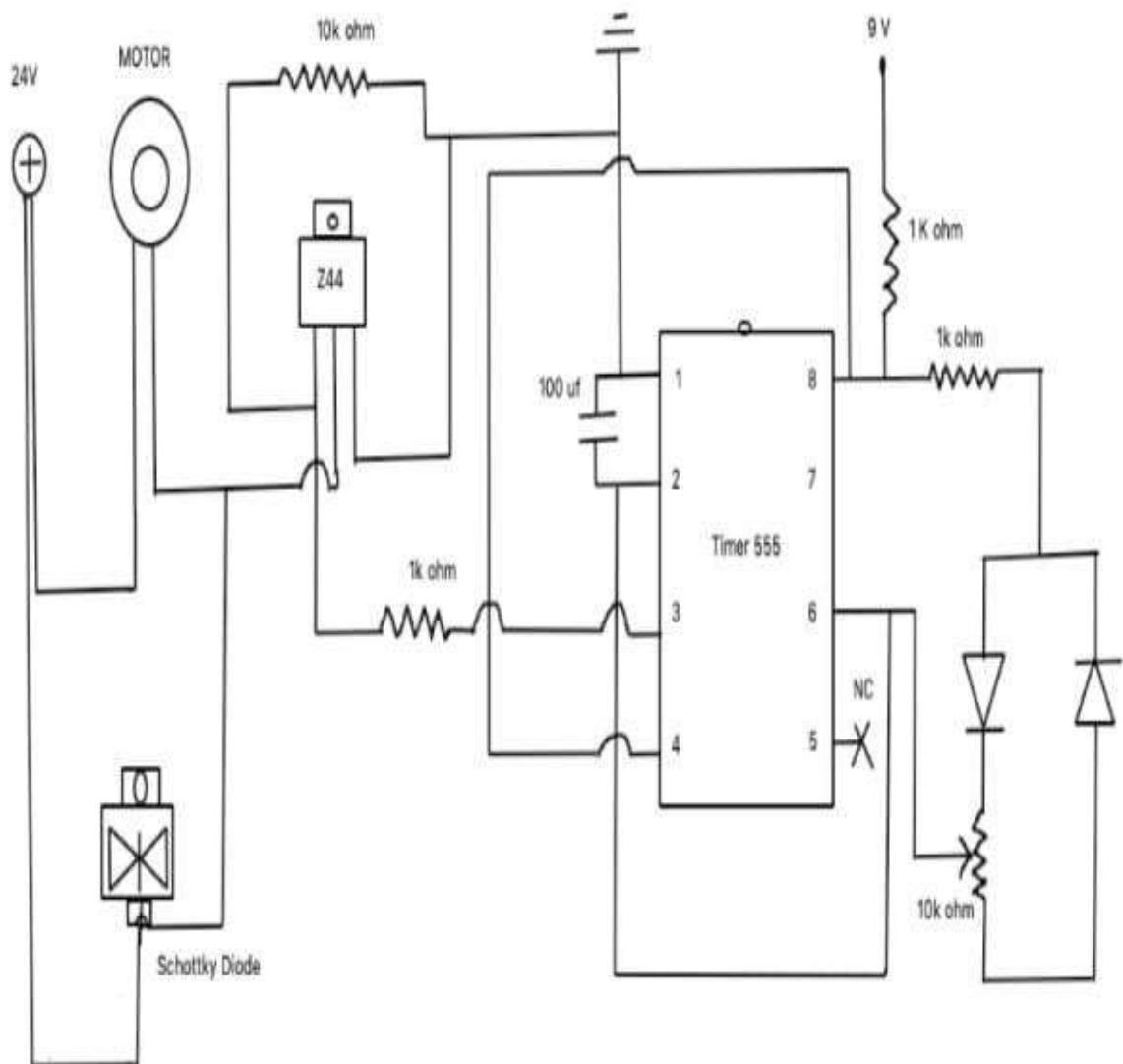

Figure 2 Circuit diagram of speed controller



Figure 3 Practical working of project

CONCLUSION

Electric vehicles are the future of our world with the increasing consumption of non renewable resources such as petroleum, diesel which leads us to step our way towards the renewable sources such as solar hydro electric power and battery. There are alternative ways by which we can save energy. One of such way is electric bike; it is also the new way of transport which provides us easy way of transport to provide of any age. It is cheap source of transport and affordable to anyone. The motor used in this bike has high efficiency and the battery bank has less weight with high speed. These bikes are environmental friendly, needs less maintenance and can be also assembled to small component.

FUTURE SCOPE

Our project “**E-Bicycle**” is used for the short distance travelling of the people this can be used in the bus stops, railway stations, metro station etc where people can access this vehicle and use it to reach their destination. As electricity has becoming the future world, as we are observing of reduction of fossil fuels in the earth crust, electric vehicles will become the future of the world, and with our project we can reduce the fuel usage combustion and also reduce the pollution in the present environment ,any age people can access this vehicle from any place to reach their destination.

Our project “E-Bicycle” is with electric battery. But in future we can also add following Solar panels,GPS,Regenerative Braking

REFERENCES

- Aikenhead, G. S. (2011). Bicycle Applications for OnBoard Solar Power Generation. 9,10.
- Maysha, Ima., Bambang Trisno., & Hasbullah. "Pemanfaatan Tenaga Surya Menggunakan Rancangan Panel Surya Transistor 2N3055 dan Thermoelectric Cooler". Program Studi Pendidikan Teknik Elektro FPTK UPI. Vol.12. 2013.
- Keogh, M. William and Blackers, W. Andrew, Accurate Measurement, Using Natural Sunlight, of Silicon Solar Cells, Research and Applications 2001; 12;1-19, Centre for Sustainable Energy Systems, The Australian National University, Canberra, Australia.
- Green MA., Emery K, King DL, Hisikawa Y, Warta W, Solar Cell Efficiency Tables (Version 27), Progress Photovoltaics : Research and Applications, 2006; 14.
- Sigit Dwi Purnama. "Sistem Kelistrikan Pada Sepeda Listrik", Teknik Mesin, Universitas Sebelas Maret, Surakarta. 2012.
- Barve, D. S. (2016). Design and Development of Solar Hybrid Bicycle. International Journal of Current Engineering and Technology, 377,378,379,380.
- FOGELBERG, F. (2014). Solar Powered Bike Sharing System. Goteberg, Sweden: Viktoria Swedish ICT.
- GOODMAN, J. D. (2010, Jan 31). An Electric Boost for Bicyclists. The New York Times.
- Prof. Palak Desai, P. D. (June 2016). Design and Fabrication of Solar Tri Cycle. International Journal of Engineering Sciences & Research, 664.

