



Wireless Surveillance Robotic Car

¹Pramod Singh, ²Vimlesh Singh, ³Harsh Vardhan, ⁴Nandaneer Maurya

⁵Ajay Sharma (Assistant Professor)

The Department of Electronics & Communication Engineering, United College of
Engineering And Research, Prayagraj, Uttar Pradesh, India

ABSTRACT

This Project is all about controlling a robot which is mounted with camera via wirelessly, camera is mounted with the robot using Node MCU ESP32. Robot is controlled through our smartphone & PC. We will create a web interface to control the Robot through smartphone & PC we will give left, right, forward, backward and stop. A wireless camera will be mounted on robot and web interface will be generated. Thus, the robot will send the live streaming to PC and smartphone through this camera using Node MCU ESP32-cam module. A wide variety of applications in present age need the use of robots as opposed of human. Robots can perform task which are hazardous for human or inaccessible to them. The basic idea of this system is based on the problem that are related to the above fact. Designing a wirelessly controlled unmanned that can be controlled via remote devices (smartphone and PC) and move in places where humans might not be able to reach shall solve many problems of applications such as surveillance, spying in defence system, used in hospitals and also in the field of science and research. By making use of rapid growing technology in robotics and automation a robot which can be controlled via smartphone with Wi-Fi network, which acts as a wireless communication link between the robot and the smartphone has been designed.

Keywords: Motor Driver Module, Node MCU ESP32-cam, Surveillance Robot

INTRODUCTION

In this Project we basically use three module the first one is Node MCU ESP-32 cam which has inbuilt with two Bluetooth, one Wi-Fi, one antenna and inbuilt 2MP Camera. We will create a web-based interface to control the robot. The web server also provides the live streaming of what the robot “sees”. It has five controls forward, backward, left, right and stop. Node MCU ESP32-cam inbuilt Wi-Fi module generates an IP address when it connected to the hotspot. We will open a browser on the IP address of ESP32- cam module and now we will able to control the robot.

Designing of a Bluetooth or Wi-Fi controlled robot is main object of this project. Bluetooth technology has average range of 10 meter, due to which car cannot travelled long distances, Bluetooth controlled surveillance robot car has a distance (limited range) issue. We will solve this limitation by using Wi-Fi module. If we used Wi-Fi in our robot then connectivity and range can be improved. Another important of developing this project is we used web interface rather than traditional hardware controllers, by this we can reduce the cost. This wireless surveillance robot car is controlled via Wi-Fi module with the help of our smartphone and PC. Web Interface is developed by using programming on Arduino Ide. Node MCU ESP32- cam module uses a microcontroller to drive this project. This microcontroller board provides ease in hardware interfacing and coding is done using Arduino Ide.

An additional feature to this Wireless Surveillance Robot car is capturing a live streaming video. This video can be seen on our smartphone and PC through Web Server. This robot can be used as a moving CCTV camera. This camera can also ensure security of the robot in case of obstacles.

OBJECTIVES

This can be controlled via using through web interface easily. This robot can be used in protection application for identifying landmines in war field and for bomb detections by using a metal detector sensor. This robot can also be used in hospitals to making deliveries and monitoring patient. This robot can also be used as time of disaster like earthquake to detect the human under building using human detector sensors. This robot most widely used as a moving CCTV camera in any organization to monitoring workers and constructions.

RELATED WORK

1. This Wireless Surveillance Robot car is capable of performing complex series of actions automatically, especially programming for the required work. This robot can also be controlled by using human operator from far distance also.
2. This project also focused on aims to build an autonomous robot in case of Pic and Place by using this robot. This robot proposes three main parts which are electrical circuit, mechanical design and third one is programming. To build a better autonomous robot, the robot must be easily and freely controlled by the users.
3. This project deals with the wireless controlled robot by using ESP32- cam module with the help of smartphone and PC by using web interface. We will simply open a browser on the IP address of ESP32- cam module and now we will be able to control it.
4. In before technology there are many methods are used design and implement and also there are many algorithms to design a robot. But these are very simple and cost efficient so we are using these methods.

METHODOLOGY

This robot has basically three modules the first one is ESP32-cam module the second one motor driver module and the third one TP5100 which can be used as power supply and charge management module. This project aims are designing a robot which can be controlled wirelessly via Wi-Fi module with help of our smartphone and PC. This robot has five controlled (go, back, left, right, stop) and capable of moving in all four directions. The main advantages of this project are economically low. This wireless controlled robot can be used for different sophisticated robotic applications. This wireless robot can be controlled by Node MCU ESP32-cam microcontroller. The data sent by our smartphone and PC can be received over Wi-Fi module which is connected to our microcontroller.

FEATURES OF THIS ROBOT

- Wi-Fi based user friendly interfacing
- Usages of Android Smartphone Wi-Fi
- Low Power Consumption
- Reduce Cost
- Easy to handle and control

This Project Focused on the following improvement:

- Wi-Fi Technology
- Interfacing Wi-Fi Module to ESP32-cam Microcontroller
- Python Programming on Arduino IDE
- PCB designing

The major buildings block of this project is:

- Regulated Power Supply
- ESP32-cam Microcontroller
- Wi-Fi Module
- DC motors with driver
- Crystal Oscillator
- Reset
- LED Indicators

HARDWARE REQUIREMENT

A. NODE MCU ESP32-CAM MODULE



Fig.1

Node MCU ESP32-cam module shown in fig.1 is an advanced version of Arduino which is combination of various inbuilt components such as two Bluetooth module one Wi-Fi and inbuilt antenna is present out of which Wi-Fi module is one of the most important components. In 2000s Arduino and Wi-Fi module are separately used to transmit data through wirelessly. But it is difficult to use Wi-Fi and Arduino separately then the evolution of node MCU is developed. Basically, it is designed by basic model of Arduino and implemented internal Wi-Fi module to it. In present day it became very simpler to connect any component through Wi-Fi which is more standard than the Bluetooth.

B. MOTOR DRIVER MODULE L298N

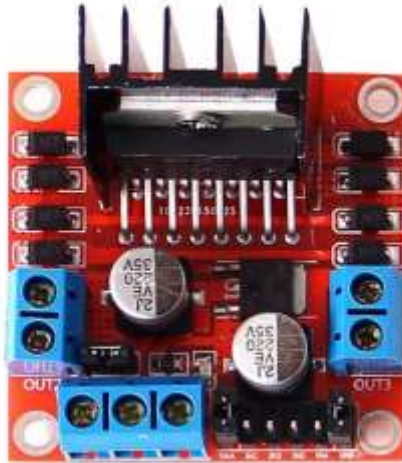

Fig.2

Motor driver module shows in fig.2 this is the circuit that is used to run the motors. This module is normally used for motor interfacing. The L298N is a dual H-bridge motor driver which allows speed and direction to control to DC motors at the same time. This module can drive DC motors that have voltage between 5V and 35 V, with a peak current up to 2A. This Motor driver module can be effectively interfaced.

C. TP5100 CHARGING MODULE



Fig.3

TP5100 is a step-down double lithium charge management module. It has inbuilt overcurrent, under voltage, short circuit protection. Along with TP5100 module also provide over temperature protection and reverse battery shutdown protection. This charge management module is used to power supply to the robot and keeps the battery safe from over and undercharging.

D. MOTORS



Fig.4

Motors shown in fig.4 are used to rotate the wheels; these motors get the power supply from the motor driver. These motors work according to the voltage supplied by the motor driver L298N.

PROPOSED SYSTEM

A 12 V DC Power Supply is applied to the Node MCU ESP32-cam Module and Motor Driver. The Node MCU gives input from the smartphone through Wi-Fi and gets output to the Motor Driver to drive the motors. Here we are using bi-directional communication between ESP32-cam and mobile. We will create a web-based interface to control the robot via Wi-Fi. The Node MCU ESP32-cam module generates an IP address when it is connected to Wi-Fi. Open a browser on the IP address of the ESP32-cam and now we will be able to control the robot.

BLOCK DIAGRAM

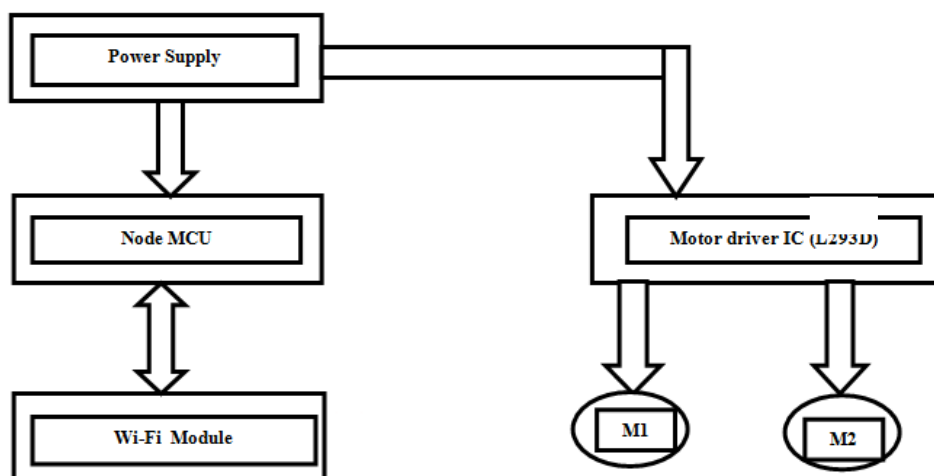

Fig.5 Block Diagram of Wireless Surveillance Robot

CIRCUIT DIAGRAM

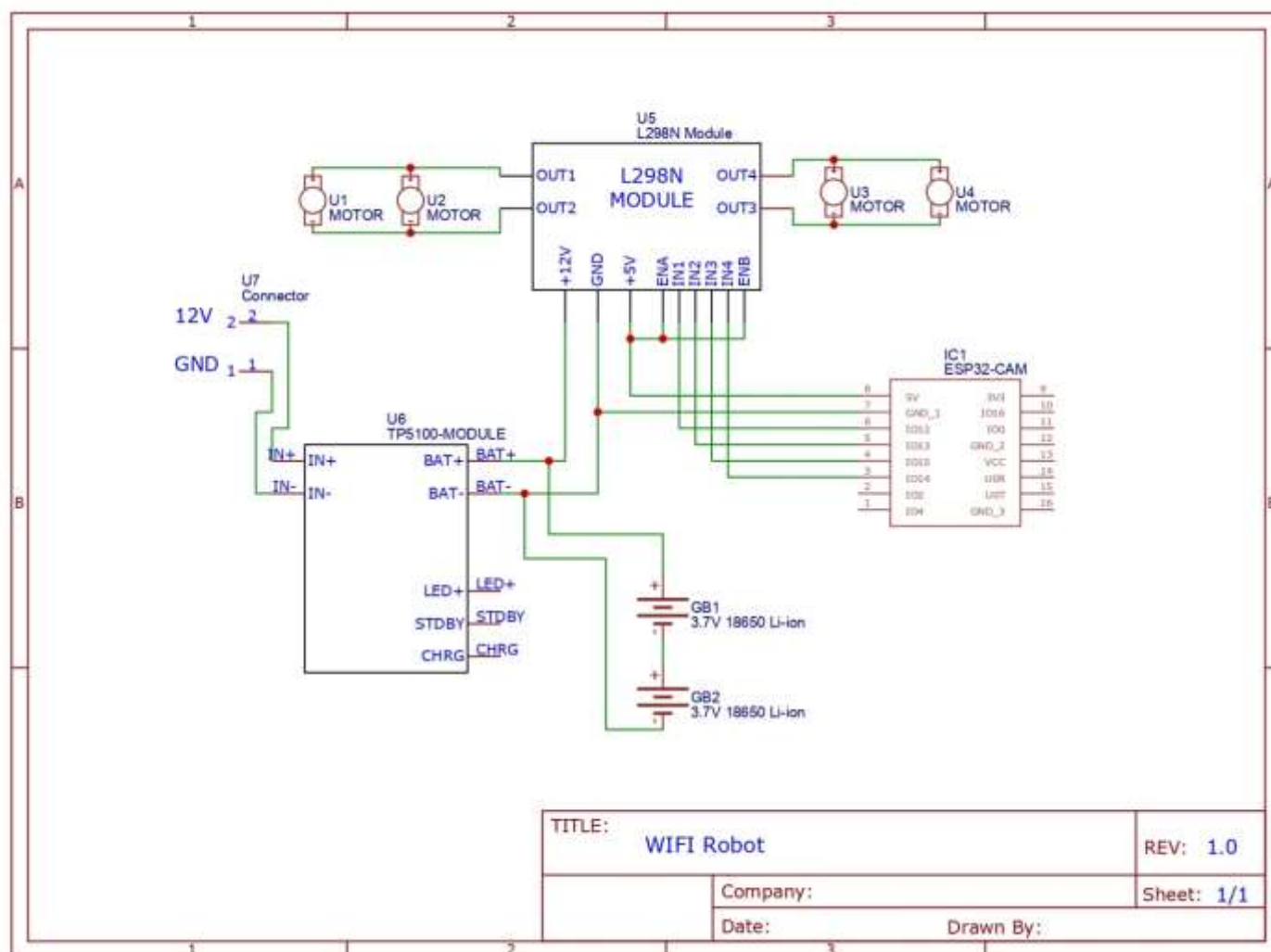

Fig.7 Circuit Diagram of Wireless Surveillance Robot Car

FUTURE SCOPE

- Multiple sensors can be added to enhance the performance of robot.
- Size and shape can be modified as per our requirement.
- This robot can be used in military operation such as mine and bomb detection.
- IR sensors can be added to detect obstacles.

CONCLUSION

In earlier devices Bluetooth is used which has limitation of limited range. But by using Wi-Fi the distance of robot can be increased. Web based interface is used to control the robot. This robot can be used in defense applications for detecting landmines and bomb. The size of devices can be changes according to the requirements. By further improving this we can also used in harvesting, fire stations and domestics uses, etc. We can also make this robot to work on its own using artificial intelligence and training it.

REFERENCES

- [1] google images
- [3] John J Craig, Introduction to robotics, Pearson Education; Third edition (2010)
- [5] IEEE sample paper template for IEEE Transactions, Preparation of Papers for IEEE TRANSACTIONS and JOURNALS (May 2007)
- [7] www.wifibot.com
- [8] 'Networking and Internet Applications' by Sangay Yeshi
- [9] <https://www.rakeshmondal.info/L293D-Motor-Driver>
- [10] <https://www.tutorialspoint.com/http/>
- [11] <https://www.techopedia.com/definition/31747/real-time-data-streaming>
- [12] <https://www.techopedia.com/definition/25705/communication-protocol>
- [13] Aruna Devi, Bharathi R, "ROBOT CONTROL USING MOBILE PHONE", International Journal for Electrical and Electronics Engineering, volume-7, Issue 2, December 2015.
- [16] Namita shinde, Shreya Srivastava, Vineet Sharma, Samarth kumar, " PAPER ON ANDROID CONTROLLED ARDUINO BASED ROBOT CAR", International Journal of Industrial Electronics and Electrical Engineering, Volume-6, Issue-3, Mar.-2018.
- [18] Akshay Bengude , Ankit Dalal, Pramod Pingle, Vaibhav Mohite, "DTMF CONTROLLED ROBOTIC CAR", International Research Journal of Engineering and Technology (IRJET) , Volume: 05 Issue: 03 | Mar-2018 .