



JOURNAL OF EMERGING TECHNOLOGIES AND INNOVATIVE RESEARCH (JETIR)

An International Scholarly Open Access, Peer-reviewed, Refereed Journal

IOT BASED VENTILATOR

Pradeep Kumar, Dr Akhilendra Yadav

Abstract – We propose the design and development of an Internet of thing based ventilator system. The ultimate vision of IoT is to upscale communication mechanisms with a highly distributed and significantly dense heterogeneous devices network. Recently world is under stress due to the COVID-19 pandemic, which causes severe respiratory distress. Therefore, it is essential to develop low-cost and high-efficiency technologies for real-time health detection and continuous treatment system. The IoT-based ventilator is a low-cost, respiratory monitoring, and controlling system. The designed and developed ventilator delivers breaths by compressing a conventional Ambu bag with the help of a fixed arm connected to a servo motor. It eliminates the need for a human operator for the bag valve mask. Tidal volume and number of breaths per minute are set via user-friendly input modes, which help in customizing the pressure according to the real-time requirements of the patient. It has a safety mode that is when the power supply goes down; the backup battery automatically kicks in. A built-in alerts system is embedded to activate and warn the local and the remote locations about any malfunctioning for immediate attention.

I. INTRODUCTION

A ventilator is a machine that provides mechanical ventilation by moving breathable air into and out of the lungs, to deliver breaths to a patient who is physically unable to breathe or breathing insufficiently.

Modern ventilators are awfully expensive. These ventilators are so expensive that for a country of 1.3 billion people there were only 47,000 ventilators. The few of the ventilators that are available are working overtime and are very susceptible to malfunction.

Most of the government hospital have very low budget so they cannot be equipped with ventilator. They have a very high maintenance cost. These machines look very small but are very expensive. And if they are not maintained properly, they can be more of a death sentence than a life saver.

This IOT based portable Ventilator is a concept to realize the advancement in health monitoring system of human beings due to the COVID-19 pandemic, the

medical facilities have been scares and are required by a lot of people.

As we all are aware of COVID-19 causes respiratory distress due to which patients face difficulty in breathing and because of which ventilators are used, which help them breath. This paper describes a prospective solution of low cost ventilators with a wireless monitoring feature. The goals and advantages of the prospective solution are: - Fight COVID-19 in countries with poor healthcare systems - Provide low-cost and low-resource ventilation devices - Help hospital staff to monitor operational functionality and parameters of ventilators with affordable and reliable Internet of Things (IoT) technology - Support Patient Management via User Interface - Compensate lower reliability of low-cost ventilators by supporting human supervision - Reduce the need for medical staff by monitoring several ventilation devices at the same time - Save Personal Protection Equipment (PPE) such as masks by reducing patient contact.

II. LITERATURE REVIEW

The COVID-19 pandemic has cast a spotlight on ventilators but are in acute shortage mainly due to the cost of it. Not everyone can afford it. India only have 47,000 ventilators for a population of 1.3 billion. MIT created an open source ventilator. A team of engineers, physicians, computer scientists, and others, centered at MIT, is working to implement a safe, inexpensive alternative for emergency use, which could be built quickly around the world.

The key to the simple, inexpensive ventilator alternative is a hand-operated plastic pouch called a bag-valve resuscitator, or Ambu bag, which hospitals already have on hand in large quantities. These are designed to be operated by hand, by a medical professional or emergency technician, to provide breaths to a patient in situations like cardiac arrest, until an intervention such as a ventilator becomes available. A tube is inserted into the patient's airway, as with a hospital ventilator, but then the pumping of air into the lungs is done by squeezing and releasing the flexible pouch. This is a task for skilled personnel, trained in how to evaluate the patient and adjust the timing and pressure of the pumping accordingly.

The innovation begun by the earlier MIT class, and now being rapidly refined and tested by the new team, was to devise a mechanical system to do the squeezing and releasing of the Ambu bag, since this is not something that a person could be expected to do for any extended period. But it is crucial for such a system to not damage the bag and to be controllable, so that the amount of air and pressures being delivered can be tailored to the particular patient. The device must be very reliable, since an unexpected failure of the device could be fatal, but as designed by the MIT team, the bag can be immediately operated manually.

The history of mechanical ventilation begins with various versions of what was eventually called the iron lung, a form of noninvasive negative-pressure ventilator widely used during the polio epidemics of the twentieth century after the introduction of the Drinker respirator in 1928, improvements introduced by John Haven Emerson in 1931, and the Both respirator in 1937. Other forms of noninvasive ventilators, also used widely for polio patients, include Biphase Cuirass Ventilation, the

rocking bed, and rather primitive positive pressure machines. Microprocessor controlled to the third generation of intensive care unit (ICU) ventilators, starting with the Dräger EV-A in 1982 in Germany which allowed monitoring the patient's breathing curve on an LCD monitor. One year later followed Puritan Bennett 7200 and Bear 1000, SERVO 300 and Hamilton Veolar over the next decade. Microprocessors enable customized gas delivery and monitoring, and mechanisms for gas delivery that are much more responsive to patient needs than previous generations of mechanical ventilators.

A lot of patients die every year due to the non availability of ventilators. Especially in rural areas this problem is very common. A lot of lives can be saved. It is a life saver for pneumonia patients and according to United Nations India saw second highest number of pneumonia deaths in children under age of 5. Ventilator can be life saver in any respiratory disorder. Most recently Covid-19 saw a wide spread that it has been categorized as pandemic and India is the second most affected country in the world.

III. COMPONENTS USED

- **ARDUINO UNO**

Arduino is an open-source platform used for building electronics projects. Arduino consists of both a physical programmable circuit board (often referred to as a microcontroller) and a piece of software, or IDE (Integrated Development Environment) that runs on your computer, used to write and upload computer code to the physical board. The Arduino Uno is an open-source microcontroller board based on the Microchip ATmega328P microcontroller and developed by Arduino.cc. The board is equipped with sets of digital and analog input/output (I/O) pins that may be interfaced to various expansion boards (shields) and other circuits. The board has 14 digital I/O pins (six capable of PWM output), 6 analog I/O pins, and is programmable with the Arduino IDE (Integrated Development Environment), via a type B USB cable. It can be powered by the USB cable or by an external 9-volt

battery, though it accepts voltages between 7 and 20 volts.

ARDUINO UNO R3 SMD PINOUT

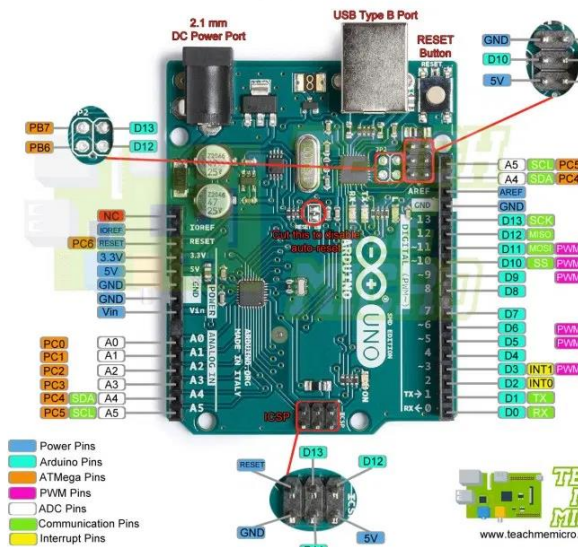

Servo motor is controlled by PWM (Pulse with Modulation) which is provided by the control wires. There is a minimum pulse, a maximum pulse and a repetition rate. Servo motor can turn 90 degree from either direction from its neutral position. The servo motor expects to see a pulse every 20 milliseconds (ms) and the length of the pulse will determine how far the motor turns. For example, a 1.5ms pulse will make the motor turn to the 90° position, such as if pulse is shorter than 1.5ms shaft moves to 0° and if it is longer than 1.5ms than it will turn the servo to 180°.

• ESP 8266

The ESP 8266 is a low-cost Wi-Fi microchip, with a full TCP/IP stack and microcontroller capability, produced by Espressif Systems in Shanghai, China

• SERVO MOTOR

A servomotor is a rotary actuator or linear actuator that allows for precise control of angular or linear position, velocity and acceleration. It consists of a suitable motor coupled to a sensor for position feedback. It also requires a relatively sophisticated controller, often a dedicated module designed specifically for use with servomotors. Servomotors are not a specific class of motor, although the term *servomotor* is often used to refer to a motor suitable for use in a closed-loop control system. Servos have three wires coming out of them. Out of which two will be used for Supply (positive and negative) and one will be used for the signal that is to be sent from the MCU.

The color coding of your servo motor might differ hence check for your respective datasheet. All servo motors work directly with your +5V supply rails but we have to be careful on the amount of current the motor would consume if you are planning to use more than two servo motors a proper servo shield should be designed.

All motors have three wires coming out of them. Out of which two will be used for Supply (positive and negative) and one will be used for the signal that is to be sent from the MCU.

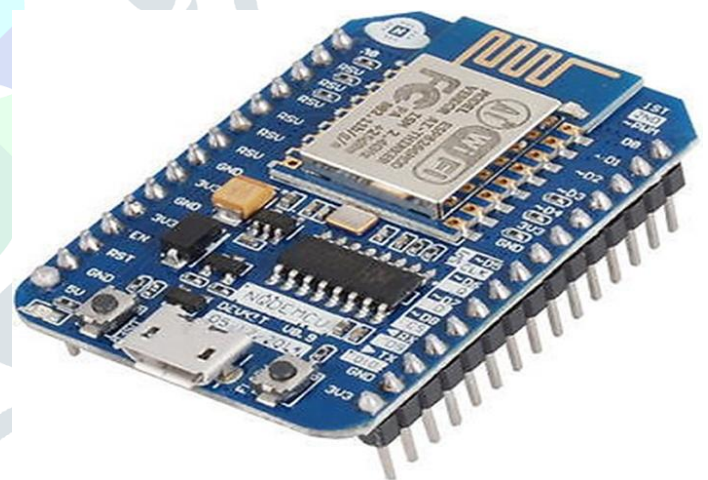

The ESP8266 WiFi Module is a self-contained SOC with integrated TCP/IP protocol stack that can give any microcontroller access to your WiFi network. The ESP8266 is capable of either hosting an application or offloading all WiFi networking functions from another application processor. Each ESP8266 module comes pre-programmed with an AT command set firmware, meaning, you can simply hook this up to your Arduino device and get about as much WiFi-ability as a Wi-Fi Shield offers (and that's just out of the box). The ESP8266 module is an extremely cost-effective board with a huge, and ever growing, community. This module has a powerful

enough on-board processing and storage capability that allows it to be integrated with the sensors and other application specific devices through its GPIOs with minimal development up-front and minimal loading during runtime. Its high degree of on-chip integration allows for minimal external circuitry, including the front-end module, is designed to occupy minimal PCB area. The ESP8266 supports APSD for VoIP applications and Bluetooth co-existence interfaces, it contains a self-calibrated RF allowing it to work under all operating conditions and requires no external RF parts.

PIN OUT

The pinout is as follows for the common ESP-01 module:

1. GND, Ground (0 V)
2. GPIO 2, General-purpose input/output No. 2
3. GPIO 0, General-purpose input/output No. 0
4. RX, Receive data in, also GPIO3
5. VCC, Voltage (+3.3 V; can handle up to 3.6 V)
6. RST, Reset
7. CH_PD, Chip power-down
8. TX, Transmit data out, also GPIO1

SPECIFICATIONS

- 4 Operating Voltage: 3.5V to 5.5V
- 5 Operating current: 0.3mA (measuring) 60uA (standby)
- 6 Output: Serial data
- 7 Temperature Range: 0°C to 50°C
- 8 Humidity Range: 20% to 90%
- 9 Resolution: Temperature and Humidity both are 16-bit
- 10 Accuracy: $\pm 1^\circ\text{C}$ and $\pm 1\%$

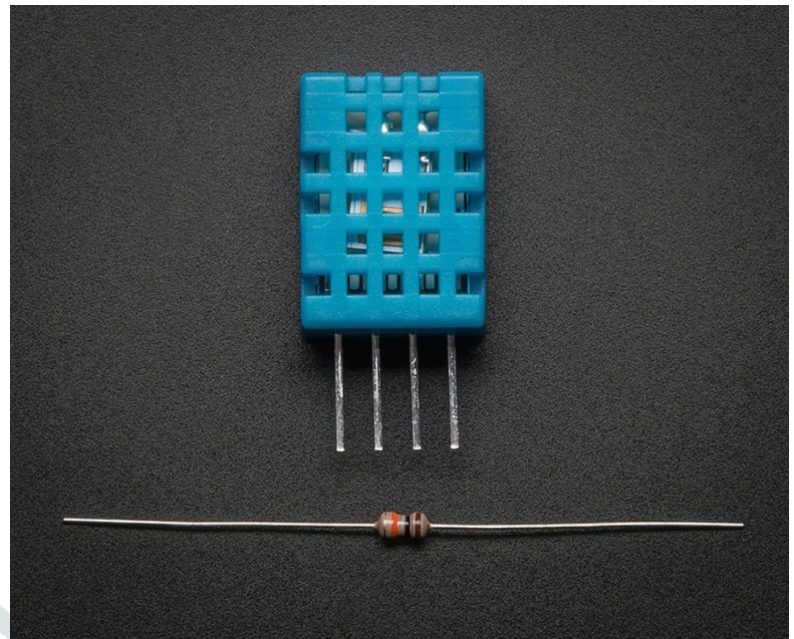

DHT 11

• TEMPERATURE SENSOR DHT 11

The DHT11 is a basic, ultra low-cost digital temperature and humidity sensor. It uses a capacitive humidity sensor and a thermistor to measure the surrounding air, and spits out a digital signal on the data pin (no analog input pins needed).

The **DHT11 sensor** can either be purchased as a sensor or as a module. Either way, the performance of the sensor is same. The sensor will come as a 4-pin package out of which only three pins will be used whereas the module will come with three pins as shown above. The only difference between the sensor and module is that the module will have a filtering capacitor and pull-up resistor inbuilt, and for the sensor, you have to use them externally if required.

• BAG VALVE MASK

A bag valve mask (BVM), sometimes known by the proprietary name Ambu bag or generically as a manual resuscitator or "self-inflating bag", is a hand-held device commonly used to provide positive pressure ventilation to patients who are not breathing or not breathing adequately. The device is a required part of resuscitation kits for trained professionals in out-of-hospital settings (such as ambulance crews) and is also frequently used in hospitals as part of standard equipment found on a crash cart, in emergency rooms or other critical care settings. Underscoring the frequency and prominence of BVM use in the United States, the American Heart Association (AHA) Guidelines for Cardiopulmonary Resuscitation and Emergency Cardiac Care recommend that "all healthcare providers should be familiar with the use of the bag-mask device."

Manual resuscitators are also used within the hospital for temporary ventilation of patients dependent on mechanical ventilators when the mechanical ventilator needs to be examined for possible malfunction or when ventilator-dependent patients are transported within the hospital. Two principal types of manual resuscitators exist; one version is self-filling with air, although additional oxygen (O₂) can be added but is not necessary for the device to function. The other principal type of manual resuscitator (flow-inflation) is heavily used in non-emergency applications in the operating room to ventilate patients during anesthesia induction and recovery.

Use of manual resuscitators to ventilate a patient is frequently called "bagging" the patient and is regularly necessary in medical emergencies when the patient's breathing is insufficient (respiratory failure) or has ceased completely (respiratory arrest). Use of the manual resuscitator force-feeds air or oxygen into the lungs in order to inflate them under pressure, thus constituting a means to manually provide positive-pressure ventilation. It is used by professional rescuers in preference to mouth-to-mouth ventilation, either directly or through an adjunct such as a pocket mask.

.1 USES

- administration of high flow O₂
- provision of PEEP (positive end-expiratory pressure)
- provision of controlled ventilation
- provision of augmentation of spontaneous ventilation

.2 DESCRIPTION

- self-inflating resuscitation device
 - bag made of plastic materials that re-expand after being manually collapsed
 - various sizes e.g. Laerdal 240 mL, 500 mL, 1600 mL bag sizes for infants, children and adults
- oxygen inlet nipple
- air intake valve

- oxygen reservoir with two one way valves
 - reservoir is at least the volume of the bag
 - oxygen flow rate equal to, or higher than, the minute volume of the patient allows 100% oxygen to be delivered
 - inlet valve allows room air to enter if fresh gas flow is inadequate and an outlet valve allow oxygen to flow out if pressure is excessive
- non-rebreathing valve that directs fresh flow of oxygen to the patient and prevents exhaled gas re-entering the bag
- standard 15 mm adapter for attaching to masks or tubes
- able to attach PEEP valve to exhalation port (either "built in" or detachable)
- can hold down pop off valve (releases at about 60 cmH₂O) to give increased pressure in the circuit
- Masks come in a range of sizes and designs
 - opaque or clear plastic
 - firm or air inflated cushion
 - mouldings vary but are designed to minimise dead space and fit

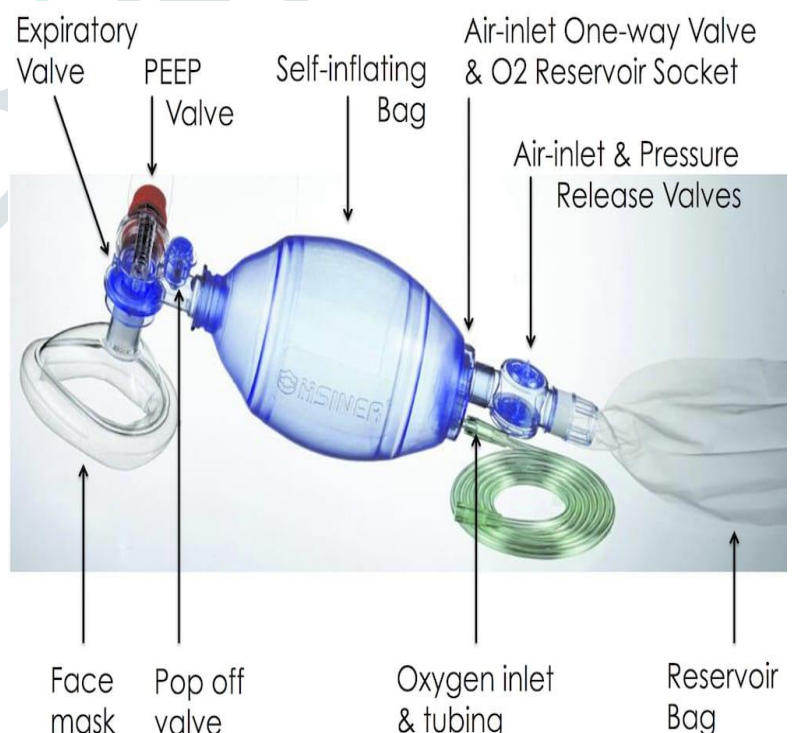

Bag Valve Mask

• RELAY

5V Relay Module is a relay interface board, it can be controlled directly by a wide range of microcontrollers such as Arduino, AVR, PIC, ARM and so on. It uses a low-level triggered control signal (3.3-5VDC) to control the relay. Triggering the relay operates the normally open or normally closed contacts. It is frequently used in an automatic control circuit. To put it simply, it is an automatic switch to control a high-current circuit with a low-current signal. 5V relay signal input voltage range, 0-5V. VCC power to the system. JD-VCC relay in the power supply. Latching relays require only a single pulse of control power to operate the switch persistently. Another pulse applied to a second set of control terminals, or a pulse with opposite polarity, resets the switch, while repeated pulses of the same kind have no effects.

Relays are the switches which aim at closing and opening the circuits electronically as well as electromechanically. It controls the opening and closing of the circuit contacts of an electronic circuit. When the relay contact is open (NO), the relay isn't energize with the open contact.



Relay

IV. SYSTEM DESCRIPTION

WORKING OF THE PROJECT

The block diagram shows the entire system which has been implemented. It consists of Arduino, Servo Motor, ESP 8266 Wi-Fi Module, Buzzer, Relay switch and Bag Valve Mask. The servo motor is used to compress the Bag Valve Mask as an arm is attached to the motor which directly compresses the bag so that air delivery can be started.

The servo motor is a very crucial part of the whole implementation as with the help of Arduino which tells the motor how much to rotate and in which direction to rotate to make the proper compressions and expansions of the bag.

The compression frequency and the tidal volume both are decided by the pre decided modes with the help of which a user can customize the flow of air according to the patient. There are three modes for frequency and three modes for volume. These are not fixed and can be changed while file tuning the ventilator. The modes can be used to change the volume and frequency of the ventilator as required.

The Arduino is the brain of the system which controls every part of the system. It tells the servo motor how much volume to give and how much frequency to the servo motor according to the modes it has. Different modes are connected to different pins so as to give variable inputs.

When the modes are pressed the speed and volume is decided by the pre-defined parameters and it sends signals according to that to the servo motors.

ESP 8266 module is used with the temperature sensor DHT 11 which senses the temperature from our hand and send it to ESP 8266 which transmits the data to Blynk IoT platform which shows the data on out phone.

3.2 FLOW PROCESS

The main purpose of the project is to use a commonly found inexpensive Bag Valve Mask and compress it to create an air delivery system so that it can help the patient in breathing. The Arduino controls every part of the system. It tells the servo motor how much volume to give and how much frequency to the servo motor according to the modes it has. Different modes are connected to different pins so as to give variable inputs.

The servo motor with the help of Arduino which tells the motor how much to rotate and in which direction to rotate to make the proper compressions and expansions of the bag.

The compression frequency and the tidal volume both are decided by the pre decided modes with the help of which a user can customize the flow of air according to the patient. There are three modes for frequency and three modes for volume. These are not fixed and can be changed while file tuning the ventilator. The modes can be used to change the volume and frequency of the ventilator as required.

When the modes are pressed the speed and volume is decided by the pre-defined parameters and it sends signals according to that to the servo motors.

ESP 8266 module is used with the temperature sensor DHT 11 which senses the temperature from our hand and send it to ESP 8266 which transmits the data to Blynk IoT platform which shows the data on out phone.

A buzzer is installed in the system so that whenever the power goes down, It automatically sounds so as to alert the attendant that power supply is down and the ventilator has stopped working and urgent attention is required. It powered by a portable battery which is installed in the device so as to power the buzzer.

WORKING DIAGRAM

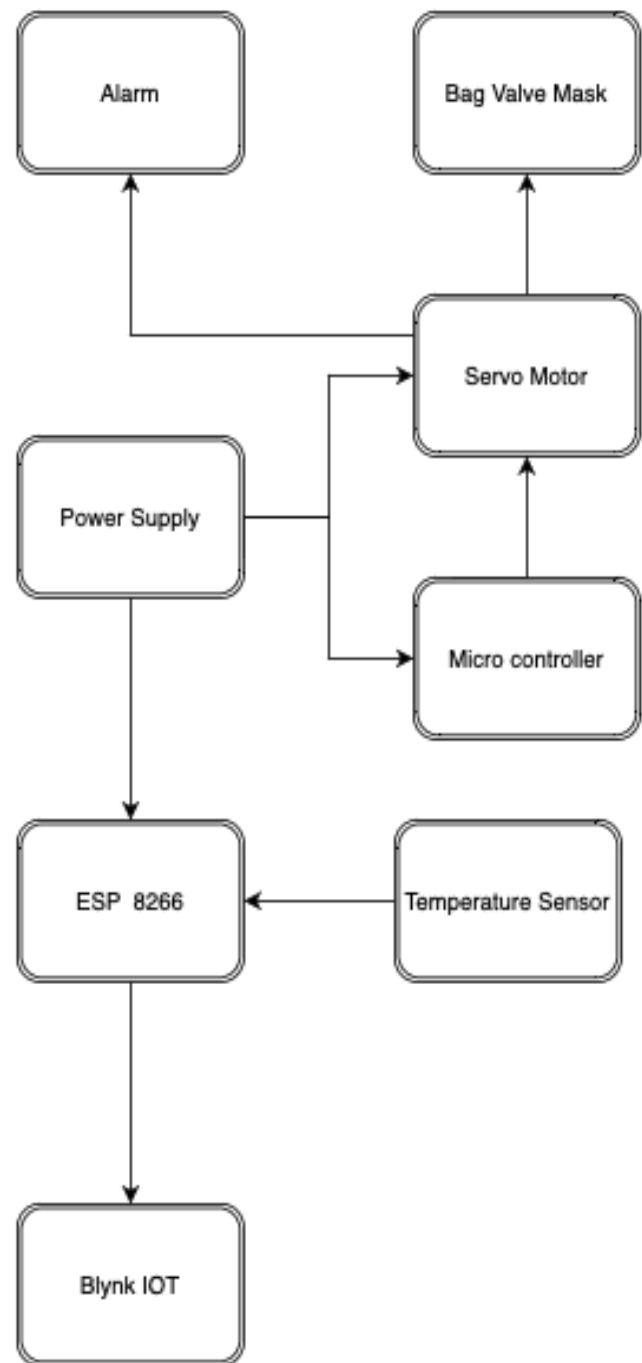

•Working Diagram of the System (showing how components are interconnected to each other)

V. IMPLEMENTATION OF THE PROJECT

The implementation of the project is comprised of two parts –

- .1 Hardware Implementation
- .2 Software Implementation
- .3 Technology Implementation

.1 HARDWARE IMPLEMENTATION

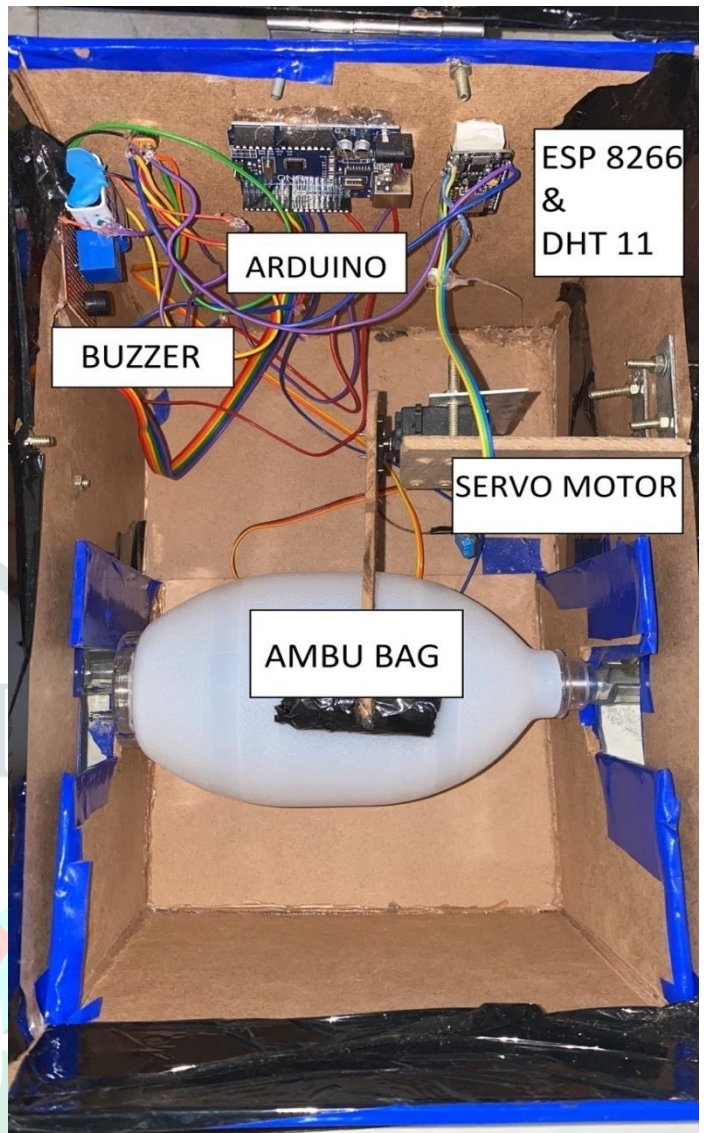

Project Image 1

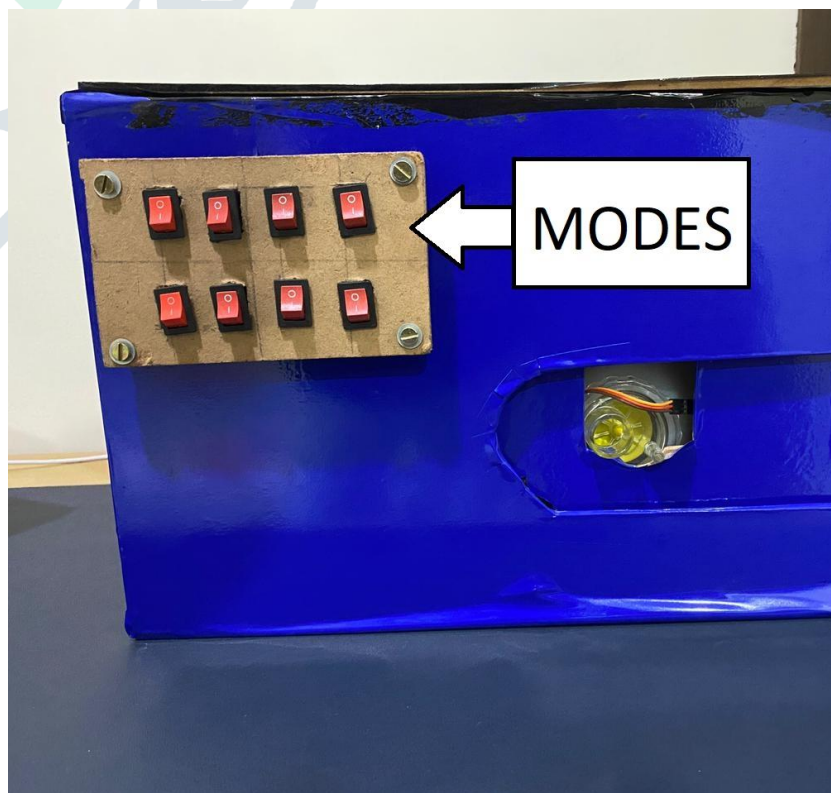

Project Image 2



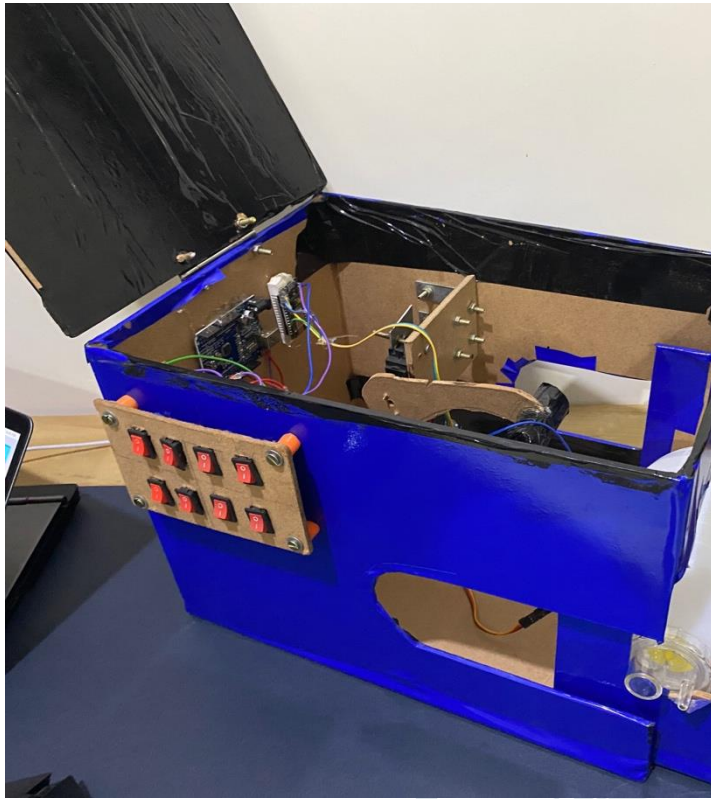

Project Image 3

The project consists of Arduino, Servo Motor, ESP 8266 Wi-Fi Module, Buzzer, Relay switch and Bag Valve Mask. The servo motor is used to compress the Bag Valve Mask as an arm is attached to the motor which directly compresses the bag so that air delivery can be started.

The servo motor is a very crucial part of the whole implementation as with the help of Arduino which tells the motor how much to rotate and in which direction to rotate to make the proper compressions and expansions of the bag.

The compression frequency and the tidal volume both are decided by the pre decided modes with the help of which a user can customize the flow of air according to the patient. There are three modes for frequency and three modes for volume. These are not fixed and can be changed while file tuning the ventilator. The modes can be used to change the volume and frequency of the ventilator as required.

When the modes are pressed the speed and volume is decided by the pre-defined parameters and it sends signals according to that to the servo motors.

ESP 8266 module is used with the temperature sensor DHT 11 which senses the temperature from our hand and send it to ESP 8266 which transmits the data to Blynk IoT platform which shows the data on out phone.

A buzzer is installed in the system so that whenever the power goes down, It automatically sounds so as to alert the attendant that power supply is down and the ventilator has stopped working and urgent attention is required. It powered by a portable battery which is installed in the device so as to power the buzzer.

2 SOFTWARE IMPLEMENTATION

The Arduino Integrated Development Environment (IDE) is a cross-platform application (for Windows, macOS, Linux) that is written in functions from C and C++. It is used to write and upload programs to Arduino compatible boards, but also, with the help of third-party cores, other vendor development boards.

The source code for the IDE is released under the GNU General Public License, version 2. The Arduino IDE supports the languages C and C++ using special rules of code structuring. The Arduino IDE supplies a software library from the Wiringproject, which provides many common input and output procedures. User-written code only requires two basic functions, for starting the sketch and the main program loop, that are compiled and linked with a program stub *main()* into an executable cyclic executive program with the GNU toolchain, also included with the IDE distribution. The Arduino IDE employs the program *avrdude* to convert the executable code into a text file in hexadecimal encoding that is loaded into the Arduino board by a loader program in the board's firmware. By default, *avrdude* is used as the uploading tool to flash the user code onto official Arduino boards.

Arduino IDE is a derivative of the Processing IDE, however as of version 2.0, the Processing IDE will be replaced with the Visual Studio Code-based Eclipse Theia IDE framework.

3 TECHNOLOGYIMPLEMENTATION

The internet of things, or IoT, is a system of interrelated computing devices, mechanical and digital machines, objects, animals or people that are provided with unique identifiers (UIDs) and the ability to transfer data over a network without requiring human-to-human or human-to-computer interaction.

A *thing* in the internet of things can be a person with a heart monitor implant, a farm animal with a biochip transponder, an automobile that has built-in sensors to alert the driver when tire pressure is low or any other natural or man-made object that can be assigned an Internet Protocol (IP) address and is able to transfer data over a network.

Increasingly, organizations in a variety of industries are using IoT to operate more efficiently, better understand customers to deliver enhanced customer service, improve decision-making and increase the value of the business.

VI. CONCLUSION

A working prototype of IoT based ventilator is designed and developed. The prototype has a user-controlled breath rate and tidal volume. The Arduino along with suitable algorithm controls the motor speed and instructs the motor about the directions of rotation. It will set the proper compressions and expansions of the bag. The compression frequency and the tidal volume both are decided by the pre-decided modes with the help of which a user can customize the flow of air according to the patient. Based on efficiency, cost, mean time between failure, and affordability this system will improve the quality of life by saving time, money, and resources. The number of variables in the feedback system can be increased to make the system more effective in handling active cases in the real-time system.

VII. FUTURE SCOPE

Further development of this proof-of-concept is planned. Future iterations will incorporate changes prompted by the results of our prototype testing. It will incorporate an adjustable inspiratory to expiratory ratio, an option missing in this prototype due to its underpowered motor. We will investigate the effects that changing the motor will cause to cost, weight and battery life. We will also incorporate add-on features including a PEEP valve, a humidity exchanger and a blow-off valve. Since BVM infrastructure already supports commercial add-ons, these components can be easily purchased and incorporated. Ways to minimize deadspace will be explored, weight will be minimized and battery-life extended. Consideration to a pediatric version will also be given. Cam arm shape will be optimized to ensure the use of the most efficient rolling contact embodiment. An LCD screen will be included, and alarms programmed for loss of power, loss of breathing circuit integrity and low battery life.

VIII. REFERENCES

- [1] AzanaHafizahMohd Aman, ElahehYadegaridehkordi, Zainab SenanAttarbashi, Rosilah Hassan, and Yong-Jin Park, "A Survey on Trend and Classification of Internet of Things Reviews," IEEE Access, Vol. 08, 16 June 2020.
- [2] Abdul Mohsen Al Hussein, Heon Ju Lee "Design and Prototyping of a Low-cost Portable Mechanical Ventilator" Proceedings of the 2010 Design of Medical Devices Conference DMD 2010 April 13-15, 2010, Minneapolis, MN, USA.
- [3] Valsalan P., Baomar T. A. B., and Baabood A. H. O. (2020). IoT-based health monitoring system. Journal of Critical Reviews, Vol.7, No.4, pp.739-742.
- [4] Al-Mutairi A. W. and Al-Aubidy K. M. (2020). Design and construction of a low-cost portable cardiopulmonary resuscitation and ventilator device. 17th IEEE Intr. Multi-Conf. on Systems, Signals, Devices (SSD2020), Tunisia, 20-23 July.

[5] Ait-Khaled N, Enarson D, Bousquet J (2001) Chronic respiratory diseases in developing countries: the burden and strategies for prevention and management, *Bulletin of the World Health Organization*, 79 (10).

[6] Chan-Yeung M, Ait-Khaled N, White N, Ip MS, Tan WC (2004) The burden and impact of COPD in Asia & Africa. *Int J Tuberc Lung Dis*.

[7] Yin Y., Zeng Y., Chen X., and Fan Y. (2016). The internet of things in healthcare: an overview. *Journal of Industrial Information Integration*, Vol.1, March, pp.3-13.

[8] Jusoh S. (2017). A Survey on-trend, opportunities, and challenges of mHealth apps. *International Journal of Interactive Mobile Technologies (iJIM)*. Vol. 11, No. 6, pp.73-85. <https://doi.org/10.3991/ijim.v11i6.7265>

