



A REVIEW ON HARMONIC FILTER BASED AC DRIVE: ANALYSIS FOR REACTIVE POWER

Madhav Kumar¹,
Shalini Goad²

²Assistant Professor, ¹²Oriental University Indore

Abstract- In the era of electrical engineering the utilization of power is a basic unconditional factor but meanwhile the utilities are suffered due to the electrical pollution or noise called harmonics. The harmonics are never been generated by the source it is generated by the load or drives. Hence the study of harmonics and the method to minimize the harmonics has been taken into consideration to develop this project work. For Understanding what is important to know about harmonics can be challenging for those without extensive engineering background. Calculations are a major part of design process in all aspects of engineering applications. This laborious and time consuming process can be made really easy by the aid of a high level engineering software like MATLAB.

This project deals with the scope and flexibility of MATLAB for:

1. Calculation of design parameters for L –C components of different branches of a harmonic filter.
2. Graphical analysis of Harmonic Pollution and different Harmonic components.
3. Verification of design using SIMULINK and Power System Toolbox before implementation to check any design error that might cause undesirable results.

1 INTRODUCTION

Generally the harmonic distortion concept has been come into observation after the research into the improvement of the efficiency of drives. Then it is observed that the harmonics are generated by the load not by a source[1]. It means the journey of harmonics from load to source.

The application of cost effective power converter circuits which enhance the performance, working efficiency, as well as the reliability of any industrial processes is common in all industry. The application area of AC to DC as well as DC to AC conversion in various industries are very large and it is increasing continuously where since 1957 SCR plays very important role.

However, the wide use of single and three phase diode/thyristor rectifiers, for DC power supplies, Adjustable Speed Drives (ASD), Uninterruptible Power Supplies (UPS), and for household and industrial appliances, took place in the last two decades. Generally the energy consume by the motor in any industrial application always utilized 65% energy out of total consumption. To improve the profitability of any industry, we have to minimized the power consumption and this is the major constrain[2]. Because variable speed drives reduce energy consumption (20-30% savings) and decrease pollutant emission levels to environment while increment in there productiveness.

As far as variable speed application is concern, the adjustable speed drives are getting used mostly to drive electric motors because this system required excellent static as well as dynamic performances. High energy efficiency and high motion quality, low starting torque, etc. are the positive attributes of the ASDs. ASDs, consists of AC/DC converter connected to DC/AC inverter. Of all the modern power electronics converters, the Voltage Source Inverter (VSI) is perhaps the most widely utilized DC/AC conversion device with commonly used Pulse Width Modulation (PWM) methods. The PWM-VSI consists of six power semiconductor switches with anti-parallel feedback diodes[3]. It converts a fixed DC voltage to three phase AC voltages with controllable frequency and magnitude. In AC motor drive applications, typically a rectifier device converts the AC three phase line voltages to DC voltage. This is just followed by rectifier along with the passive filter. Commonly capacitor with or without reactor are used. The voltage source invertors are getting interface DC source to the AC motor for controlling speed of shaft position of shaft and torque of the shaft. Therefore most of the application prefers 6 pulse rectifier of diode or thyristor which helps to improve the efficiency and reliability but cost will be reduced. The basic structure of 6 pulse diode rectifier with drives is given bellow

i.e. in fig. 1.1

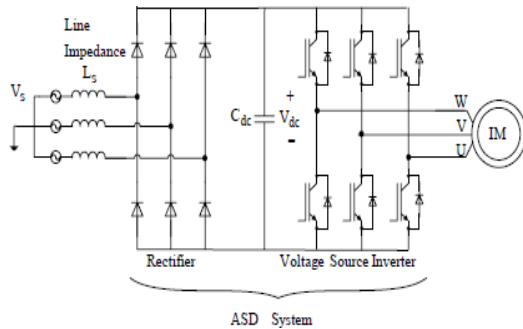

Fig.1.1 The Main Structure Of PWM-VS Diode Bridge Rectifier Front-End AC Drive.

2 LITERATURE SURVEY

When the pollution or harmonic distortion concept is going to be discussed then it is found that this is a major area where the power quality issues are considered. According to Clyde Glikar[12] the harmonic distortion always affects some utilities as well as research organization power industries, where harmonics are getting generated by the load and getting reflected towards the source. This results into excessive power requirement and generates the heat. Therefore this paper suggests a use of capacitor bank towards the load so that harmonic distortion can be minimized.

According to B. C. Smith and N. R. Watson[13] the harmonic distortion can be minimized in AC as well as DC drives system by adopting the different converter technique. These converter techniques are used to control the harmonic modulation by means of filtering and commutation angle. The various 3 Φ , 12 pulse converter are generally used or configured for the large power applications, but while using this kind of converter V and I sources are considered for the distortion.

The 3 harmonic simulation text of the design system has been discussed by G. Bathurst and N. R. Watson[14][15] where the demonstrating guideline has been provided through different case study and the different examples. The different example of simulation has been provided for harmonic problem. According to him evaluation has been made in existing software which is used for the analysis of harmonics and develop the new method for harmonic simulation. The comparative study of fundamental harmonic data and its effect over THD and after evaluation available new data has been compared. This is one of the effective methodology for the design of harmonic filter in order to reduce the total harmonic distortion.

Generally in harmonic reduction technique the PWM i.e. pulse width modulation technique is widely used along with H bridge invertors for various industrial applications[16] where uninterruptible supply is produced with the help of active filters and class D power amplifier. According to Henry Shu Hung Chung and C. M. Wu the ideal pulsewidth modulated signals are getting generated to apply it to gate driver circuit. The invertors output is deviate from the given expected because of only the nonideal switching devices which are used at the output. Actually it will be the introduction of the dead time which is to avoid the cross conduction of current flowing through the invertors. There will be cross over in between lower and the upper switches which will go to produce the additional distortion in the system. The distortion has been introduced because of the dead time.[17] these effects have been observed by many researchers throughout the last decade. The dead time is as good as the delay in the system which always affects the operation of the AC drives or motor. While using the class D power amplifier this dead time is going to produce extra harmonic distortion at the output stage. Therefore number of methods are getting developed to solve the problem of such kind of distortion. Comprehensive numerical methods are used to find out the width and the actual position of the pulses or simply PWM pulses so that we can calculate the pulse train of the dead time.

According to Katsumi Yamazaki[18] when the any kind of drives are going to design the estimate of harmonic electromagnetic is very important as well as essential part. For simulation with the practical approach example small size of induction motors with high output. to fulfill the condition the nonlinear 2 dimensional time stepping finite element method type 111 are commonly used while it is applicable to analyzer for the motors. This kind of method always need greater than thousands calculation or simply iterative calculations. For calculating the time harmonics the backward difference method is commonly used. When the PWM invertors is going to drive the motor then to distinguish the carrier frequency for an inverter the number of time steps required will be large. In this condition the Newton Raphson method will provide the simple calculation by considering the magnetic saturation.[19] on other side the electromagnetic field always influence the characteristics of the motor. The end rings and the bar of rotor always decide the secondary resistance. The leakage inductance is totally depends upon the sharp of coil ends. And to estimate this end effect 3 dimensional analyzer are used. Where we can reduce the number of calculation for the harmonics. When in the topic of harmonics the transmission system has been considered then it offer a positive sequence. When the system for power transmission has been designed for limiting the asymmetry of voltages to the very low level always by taking the help of the line transpositions. Therefore the waveforms of AC current at HVDC convertors as well as its characteristics the harmonic components are getting derived from the gettable information from single

phase(1 Φ) AC-DC load flows.[20] according to B.C. Smith and J. Arrillaga by ignoring the asymmetries of converter as well as system this kind of approach is not able to predict harmonic behavior for non characteristics. For the terminal voltage of unbalanced fundamental frequency it produced the response by injecting harmonic current to all kind of odd triple frequencies. It may be in negative or in positive sequence. The third harmonic and the ninth harmonic may be substantial. The accurate and exact derivation for the non characteristic harmonic current will required the converter unbalanced at the terminal because of AC system as well as the converter itself.[21] For the solution of this in 3 Φ all the relevant frequencies are getting required. Hence required elements are well defined in this survey paper.

The main advantage of voltage source inverter is that it required very low starting current and very much energy saving specially the application in fan and pumps these kind of drives are commonly used in now days application. Therefore DC power supply for the invertors are getting generated by using the simple bridge diode rectifier by feeding a very large capacitor for filtering purpose[22]. According to Manfred Grotzbach if effect produced by the inductance in order to current smoothing purpose is not enough sufficient then very much line current harmonics are generated. This kind of current harmonics are generated at internal impedance of the given supply network which will corresponds the very high voltage harmonics. Which should not get exceeds a certain amount of limits in terms of other load as comparing the emission slandered specified in slandered [23]. The very simple method of reducing these type of high current harmonics will be the additional connection of inductance or choke this has been find out in simulation studies. In opposite to the DC sided smoothing inductance there is a AC inductor or choke has been add a electrical distance among supply network and the drives. As per the product slandered for the adjustable speed drive system or simply we can say that ASD the manufacturer or the system designer should get provide the level of the current harmonics under the given rated conditions. The drives are getting loaded bellow the capacity because of the overrating of drives. If we consider the drive like fan or pump where the demand of the load is nearly 35% to 60% of the given rated one[24]. This paper has given that how to determine the exact line current distortion which having under the consideration of the drive which is actually loading and it get maximum realistic results as the improvement of injected current harmonics in the aim of the analysis of harmonics. It also included the parameter DC capacitor as well as the AC reactance which are the effective parameter normalization which are getting applied to the current results of the sophisticated evaluation in the user friendly circuits or the diagrams.

The solid state converter applications for the speed adjustable drives is very much preferable in industrial applications because of the enhancement in the technology of power transistor. it helps in the improvement of flexibility as well as efficiency.[25]. According to Mohammed Bashir and Thomas H. the current distortions are getting generated by the adjustable speed drives. This matter has been concerned since last many years. And for dealing with such kind of problems of harmonics the number of different methods is developed. Hence the systematic design methods for drive system will have the limited impact over the source in terms of harmonics. The drives comes under the discussion in which the inter harmonics are getting presents. Where we can define the inter harmonics in such a way that the steady state voltage or current which is not having the inter multiple of their fundamental frequency. The diode bridge type rectifier is used for power conversion at input level in many of the drive system which are speed adjustable. Where the PWM invertors will invert the voltage of dc link with variable frequency and the variable voltage at ac load. In the power system the inter harmonics are created by harmonic current of the inverter when it will going to propagate through the dc link. This topic is a case study of the relationship among the ac source, dc link reactor and inverter load system mention by the above author. He investigated the conditions where it leads the inter harmonics available in the given supply has been identified. But the balance case along with the linear modulation is the criteria for the inverter. The dc link harmonics are getting find out at the highest order harmonics. This highest order harmonics are getting block by the inductance i.e. dc link inductance. The current harmonics of source current are getting evaluated for the different values of the frequencies by which the inverter is operating. Hence there is no inter harmonic are found along with the unbalanced load or simply we can say the over modulation. Hence the achievable level for harmonics current was found exist there. Currently in the market some adjustable devices are available to measure the relationship between some a inter harmonic current inside the source and the unbalance load even though the these level are not to much high as compare to the harmonic current which is actually drawn by the source. the appearance at the inter harmonic frequency is a reason of the concern. In this survey paper the recent evaluation of the given mechanism are getting involved for the generation of the inter harmonic developed by the over modulation and load imbalanced. It is going to represent the study of various effect on the given inter harmonics due to the variation of dc link inductance as well as source inductance. These indicate that the similar type of effect on inter harmonic level are getting produced by the inductances. And the prediction of inter harmonic level for the given source situation as well as wide range of dc link has been mention in this survey paper.

According to Y. Baghzouz and R.

F. Burch [26] when the the survey of electric utilities has been performed then it has been observed that the voltage on electrical delivery system will be responsible for the generation of harmonic level to the great extend. This might be initial step in the very wide useable area of electrical utilities where we can spread these utilities in industrial, domestic or any commercial purpose. Hence the harmonic effect potentially on the various power equipments and the operation of the system will become in concern with the utilities. Therefore in the relation that the harmonics are not ignore for a long span of

the time. If it is going to be ignore then there is a problem for the many industries and mainly for the transformer as well as conductors from overheating. Since last two decade the special attention have been given to the analysis of the deterministic harmonics. The criteria for the deterministic is that ignoring the variability of operating condition of non linear load which results into the change in that harmonic current which is injected by the load connected to that network of utility. The measurement of the field are clearly indicating that the current as well as voltage harmonics are the time variant because of continual changes occurs in the condition of the load and it may be due to change in the configuration. In this survey paper the philosophy which is very common says that for conducting a deterministic study which will be based upon the very worstcase so that safety margin can be provided in the design of system and the operation. But while performing this effort the cost and the size will become unnecessarily expensive hence we will approach towards the statistical techniques for the analysis of the harmonics which is well suitable. Some other studies are also mention here like conventional studies or probabilistic study for load flow and the fault study[27]. Such techniques are helpful to calculate the voltage harmonics and the current harmonics which is not simply based upon expected maximum or the average value but it should get obtainable on various probabilities of gettable values. Even though in the real power type of network probabilistic analysis of harmonic is not to easy task the number of factors are getting included in this just like it will going to include the large number of various non linear load which will generate the harmonic current which depend upon the supply voltage. And the continues change in the load composition on the feeder. Lack of data for these several type of load, and the modeling of role for harmonic frequencies are very complex and not able to understood fully. The characteristic of harmonic voltage are getting affected due to the dispersed nonlinear load.

From all above literature survey one suggestion has been comes out that harmonics are not permanently removed it can be reduced or minimized in order to reduced the total harmonic distortion the dc link reactors inductor and the capacitor should get place together, by taking this consideration our project work moves towards the design of harmonic filter to minimized the total harmonic distortion.

3 CONCLUSION & FUTURE SCOPE

The use of simulation tools as MATLAB/ Simulink, allows reproducing the behaviour of the power systems in different situations, analysing how the system answers in these situations and choosing the solution that better fit with the particular problem without additional costs. However for the analysis of different harmonic distortion and its reduction the passive filters having different values may be simulated. By performing the simulation we approach the reduction of the values of the voltage as well as current harmonic distortions because of an underground traction system & a steel industry has obtained. Hence the reduction of the distortion by implementing the passive filter has been simulated for mention systems.

As per IEEE 519 standard the major factor for power quality degradation is Harmonic pollution. Harmonic Filters will reduce the effects of harmonics as well as it will provide reactive power for improvement of power factor. With the help of MATLAB all the parameters of harmonic filter can be design very effectively and easily.

In MATLAB program harmonic analysis has been done by using harmonic analyzer, and according to that data has been fed. Any input data can be used multiple times by using MATLAB GUI. The graphical analysis has been regenerated by the MATLAB for our study case which will take data from harmonic analyzer. To check the proper working of designed filter, the considered values has been verified by SIMULINK

Thus all the process of analysis, design as well as verification has been done in a very short time and correctly in MATLAB.

In the future scope of this project we can design the hybrid system in order to reduced THD.

Active filter also get design to achieve the same goal. But when the active filter is going to design we have to take the help of neural network (ANN). By using PWM rectifier the THD can be control.

REFERENCES

1. Valentin Dzhankhotov and Juha Pyrhönen, Member "Passive LC Filter Design Considerations for Motor Applications", IEEE vol. 60, no 10 October 2013.
2. Andrés A. Valdez-Fernández, Member, IEEE, Pánfilo R. Martínez-Rodríguez, Member, IEEE, Gerardo Escobar, Senior Member, IEEE, Cesar A. Limones-Pozos, and José M. Sosa, Member "A Model-Based Controller for the Cascade H-Bridge Multilevel Converter Used as a Shunt Active Filter", IEEE, Vol. 60, no. 11, Nov. 2013.
3. Sachin K. Jain Member, IEEE, S. N. Singh Member, "Fast Harmonic Estimation of Stationary and Time-Varying Signals Using EA-AWNN" IEEE, Vol. 62, No. 2 Feb 2013.
4. Rafael Peña-Alzola, Marco Liserre, Frede Blaabjerg, Rafael Sebastián, Jörg Dannehl, and Friedrich Wilhelm Fuchs "Analysis of the Passive Damping Losses in LCL-Filter-Based Grid Converters", IEEE Vol. 28, No. 6, June 2013.
5. Tae-Chul Jeong, Won-Ho Kim, Mi-Jung Kim, Ki-Deok Lee, Jae-Jun Lee, Jung-Ho Han, Tae-Hyun Sung, Hee-Jun Kim "Current Harmonics Loss Analysis of 150- kW Traction Interior Permanent Magnet Synchronous Motor Through Co-Analysis of - Axis Current Control and Finite Element Method", IEEE Vol. 49 No. 5 May 2013.
6. Chawasak Rakpenthai, Member, IEEE, Serm Sak Uatrongjit, Member, IEEE, Neville R. Watson, Senior Member "On Harmonic State Estimation of Power System With Uncertain Network Parameters", IEEE, Vol. 28 No. 4 November 2013.
7. Jen-Hao Teng, Member, IEEE, and Chuo-Yean Chang, IEEE "Backward/Forward Sweep-Based Harmonic Analysis Method for Distribution Systems", Vol 22 No. 3 July 2007.
8. Changjin Liu, Frede Blaabjerg, Fellow, IEEE, Wenjie Chen, and Dehong Xu, Senior Member "Stator Current Harmonic Control With Resonant Controller for Doubly Fed Induction Generator", IEEE, Vol. 27 No. 7 July 2012.
9. Yu Cui and Xiaoyu Wang, Member "Modal Frequency Sensitivity for Power System Harmonic Resonance Analysis", IEEE, Vol. 27, No. 2 April 2012.

10. Katsumi Yamazaki, Member, IEEE, and Shinjiro "Loss Analysis of Permanent- Magnet Motor Considering Carrier Harmonics of PWM Inverter Using Combination of 2-D and 3-D Finite- Element Method" IEEE, Vol. 41, No. 5, May 2005.
11. Stavros A. Papathanassiou, Member, IEEE, Michael P. Papadopoulos, Member "Harmonic Analysis in a Power System with Wind Generation", IEEE, Vol.21, No.4, October 2006.
12. Clyde Gilker, Rory K Dwyer, Roger C. Dugan "A Program for Analysis of Power System Harmonics" IEEE Computer Applications in Power 1989.
13. C Smith J Arrillaga A R Wood N R Watson "A review iterative harmonics analysis for AC Dc power system", IEEE, Vol. 13, No. 1, January 1998.
14. N. R. Watson and G. Bathust, "Test Systems for Harmonics Modeling and Simulation", Vol.14, No. 2, April 1999.
15. Ben-Sheng Chen and Yuan-Yih Hsu, Senior Member "An Analytical Approach to Harmonic Analysis and Controller Design of a STATCOM", IEEE, Vol.22, No.1, January 2007.
16. C. M. Wu, Wing-hong Lau, Member, IEEE, and Henry Shu-hung Chung, Member "Analytical Technique for Calculating the Output Harmonics of an H-Bridge Inverter with Dead Time", IEEE, Vol. 46, No. 5, May 1999.
17. Yu Cui, Student Member, IEEE, and Wilsun Xu, Fellow "Harmonic Resonance Mode Analysis Using Real Symmetrical Nodal Matrices", IEEE, Vol. 22, No.3, July 2007.
18. Katsumi Yamazaki, Member, IEEE "Induction Motor Analysis Considering both Harmonics and End Effects using Combination of 2D and 3D Finite Element Method" IEEE Vol. 14., No. 3, September 1999.
19. J.C. Das, "Passive Filters – Potentialities and Limitations," IEEE Trans. On Industry Applications, vol. 40, no.1, Jan./Feb. 2004, pp.232-241.
20. B.C. Smith Non-member J. Arrillaga "Power Flow Constrained Harmonic Analysis in AC-DC Power Systems" IEEE Vol.14, No.4, November 1999.
21. H. Akagi, "Active and Hybrid Filters for Power Conditioning," IEEE Industrial Electronics Conf. Proc., vol. 1, 2000, pp. TU26-TU36.
22. Manfred Grötzbach, Member, IEEE, and Reiner Redmann "Line Current Harmonics of VSI-Fed Adjustable-Speed Drives", Vol. 36, No.2, March 2000.
23. L.L. Grigsby, "The Electronic Power Engineering Handbook," CRC Press, 2000, ISBN 0-8493-8578-4.
24. B. Singh, K. Al-Haddad, A. Chandra, "A Review of Active Filters for Power Quality Improvement," IEEE Trans. on Industrial Electronics, vol. 46, no. 5, October, 1999, pp. 960-971. Mohammed Bashir Rifai, Thomas H. Ortmeier, Member, IEEE, and William J. McQuillan "Evaluation of Current Interharmonics from AC Drives", IEEE, Vol.15, No.3, July 2000.
25. M. Zeraoulia, and *et al.*, "Electric motor drive selection issues for HEV propulsion systems: A comparative study," IEEE Trans. Vehicular Tech., vol. 55, pp.1756-1763, Nov. 2015.
26. L. Chang, "Comparison of ac drives for electric vehicles- A report on experts' opinion survey," IEEE AES Systems Magz. pp.7-10, Aug. 2014.
27. T. Backstrom, Integrated energy transducer drive for hybrid electric vehicles, PhD Thesis, Royal Institute of Technology, Sweden, 2010.
28. C. Mi, "Analytical design of permanent- magnet traction-drive motors," IEEE Trans. Magn., vol. 42, pp. 2012-2014, July, 2013.
29. Y. Fujishima, S. Vakao, M. Kondo, and N. Terauchi, "An optimal design of interior permanent magnet synchronous motor for the next generation commuter train," IEEE Trans. Applied Superconductivity, vol. 14, pp.2010-2011, June 2004.
30. F. Magnussen, P. Thelin, and C. Sadarangani, "Design of compact permanent magnet machines for a novel HEV propulsion system," in Proc. 20th Int. Electric Vehicle Symposium and Exposition, Long beach, California, USA, 15-19 Nov., 2010, pp. 181-191.