



WiFi ENABLED IoT BASED PATIENT HEALTH MONITORING SYSTEM

¹ Mr. Vivek Sharma, ² Amit kumar Sharma, ³ Abhishek Kumawat, ⁴ Akash Sharma, ⁵ Amar Chopra

SWAMI KESHVANAND INSTITUTE OF TECHNOLOGY, JAIPUR

Abstract: *Technology plays important role in life. Also Technology play vital role in Medical. It is one of the Necessary system for design. Healthcare nowadays is important and after covid also important. So IoT Based health monitoring system is good for check the health. In this paper a portable physiological checking framework is displayed for constantly monitoring by heartbeat sensor, pulse sensor and temperature sensor. Microcontroller and IoT has used in this system. The monitoring procedure can be performed anytime and any where without the need for a hospital. Utilizing of Wifi Technology and Microcontroller so it is better for doctor's and patients relatives. For the reason fast conditionl Medication may be simply done by this technique.*

Keywords: *Microcontroller, Wireless Technology, Patient monitoring system*

I. INTRODUCTION

Nowadays, wireless technology has increased in various sectors such as control, automation, etc. To provide better healthcare service, the biomedical field uses the Internet of Things. The Internet of Things is used in hospitals as well as personal health care systems. To ensure innovative work this kind of technology is used by doctor.

Future new mega trend of internet is IoT Visualising a world wherever several objects will sense communicate and share data over a personal net protocol or public networks can be done through IoT. The interconnected objects collect the data at regular intervals, analyse and initiate needed action. In this Project multiparameter monitoring system that will monitor pulse rate, heart rate, and temperature simultaneously.

They used the Arduino and ESP8266 Wi-Fi Module and two sensors modules to design an IoT-based patient monitoring system that can detect two primary vital signs of body temperature, body temperature and heart rate and showed the value on an LCD display. This paper has been described about the system of Internet of Things and its use in the health care department

1.1 Purpose of this project

The main purpose of this project is easily check the health of patient and simply used for doctor's. Also relative check Health of patient. By the use of Technical and Wireless device easy to check. Nowadays Health is Big issue for everyone So it is important for future. Combination of Arduino (Microcontroller) and Wireless technology (wifi) so easy to check the health. Technology play important role in every field. By Connect of IoT (Internet of Thing) so widely used in Wireless technology. Several different recognition and algorithm used in this project.

1.2 Proposed System

In this project, a system for 24*7 human health monitoring is Designed and implemented. In this system, the Arduino Uno Board is used for collecting and processing all data. Different sensor are used for measuring different parameters. All these data uploaded to thingsspeak for mobile analysis. An ESP8266 module is used for connecting to the

Internet. Used of Pulse sensor, LM35 Temperature Sensor, 16*2 LCD Display, ARDUNIO NANO. The data

Of the Patient's Health stored in the cloud. The doctor can easily access the Patient's health anytime from anywhere.

An LCD is also connected to the microcontroller to the patient to view their live status. In such case patient gets rapid medical help and also would save time and energy.

1.3 Fundamental of Patient Health Monitoring System

In IoT based Patient Health monitoring system Sensor work as collect the patient health data and show in

LCD 16*2 Display. All sensor work in his Proper way. LM35 sensor temperature devices with an output voltage linearly-proportional to the Centigrade temperature. Use of ECG (Electrocardiogram) ECG work on the principle of like Operational Amplifier The Pulse sensor is plug and play Heart rate sensor for Arduino.

. Heart rate sensor give digital output of pulse rate sensor. The ESP8266 (Wifi) is useful and low-cost device to provide internet connectivity to your projects. The module can work both as an Access point (can create hotspot) and as a station (can connect to Wi-Fi). Microcontroller have (Arduino Nano) used.

Block Diagram

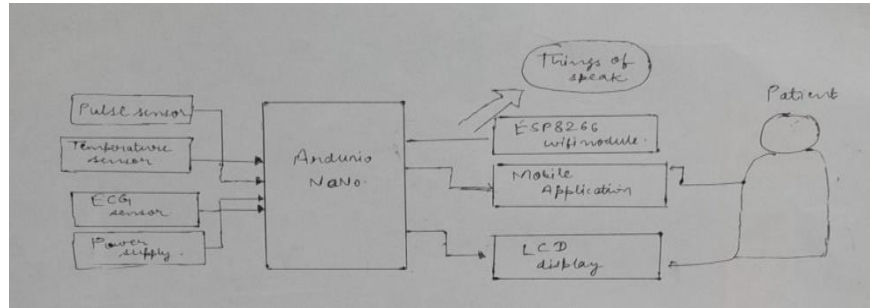

Fig 1

2. Methodology

Working of IoT Based Health monitoring system divides in two parts:-

- Hardware part
- Software part

Hardware Model:- In Firstly hardware parts arrangement is very important for Patient health monitoring system. LM35 temperature sensor, Pulse sensor, ECG connected with Arduino nano and ESP8266(wifi) Module. The LM35 series are precision integrated-circuit temperature devices so they show body Temperature and also room temperature. Heart rate sensor give digital output of pulse rate sensor.heart beat detector is working then led sensor is working. BPM rate show in LCD Display.

It will control the all devices we used in this system. Arduino Nano is free source Microcontroller based on microchip at mega 328p. So Hi-waote battery commonly used and portable Used. Battery have Non rechargeable and high capacity used battery. Used in many electronic device. And in this project we have used.

Software Model:- Secondaly Software part is also important part based on (IoT) application. ESP2866(wifi module). Use of Codes put the values and connected to microcontroller (Arduino Nano). And In ECG have to used codes. Arduino1.6.11 software use so all data have to store in system.

Work Process:-

Pulse Sensor :- Clip the pulse sensor to fingertip and Plug in Arduino. So it ready to check heart rate.

In pulse sensor Vcc,Gnd and Analog pin to connected. Also led in centre so help to detect The heartbeat. Noise elimination circuit in below of led sensor so they eliminated the noise.Pulse sensor pin connect A0 of Arduino and two pins VCC&GND.

LM35(temperature sensor): It is precision Integrated circuit temperature device so linearly-proportional To centigrade temperature. And show room temperature.In this three pin connected 1.(4-20)V 2. Out pin 3. GND have to connected to lcd display microcontroller Then they give the data. Also same as pulse sensor.

ECG Sensor(Electrocardiogram):- In electrical activity its ECG and show output as analog reading. ECG is noisy AD8232 Single Heart rate monitor.Act like opm-amplifier. Connector are SDN, LO+, LO-, OUTPUT, 3.3V, GND provide pin to operate with Arduino Nano.

ESP8266 work only with 3.3v and more of 3.7v.Ground pin connected with circuit Input/output pin also connected. ESP8266 module not work directly to Arduino. Firstly divide in voltage then they work.

IoT(Internet of Things) is good tool for IoT based project. By using thinks speak application easily Monitor our data and control system by used of internet. First Need to signup and create account. Create API key. Upload code to the Arduino Nano . In Mobile application connect to wifi and see thethe result.

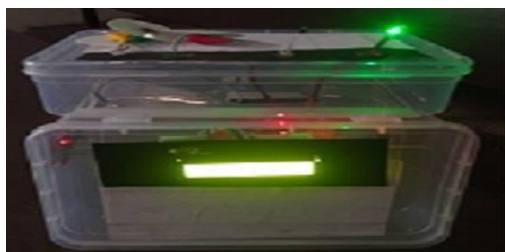

Fig 2



Fig 3

Scope and Application:-

This Project is important for elder person they have alone at home. Also helpful for senior citizen. Disabled patient who find not go to doctor also helpful for these patient. This project helpful for doctor for find history of patient easily. Record mainting is also by in digitaly and paper also.

Health parameter of patient store in cloud. Notification also send to doctor where patient is notprovide detail.

Conclusion:-

Wide use of Internet so wireless communication work in this project. IoT rule in many sector mainly in health care sector. Present work done in IoT based application. And Arduinio Nano microcontroller use is widely increase. In electrical all electronic parts and wireless technology combine is better use in medical sector. Information send to LCD display. Doctor can check the data of patient and by logging the website and IP address. Hence continous patient monitoring system is designed.

Future Work :-

In Future work design of system in advanced. Connect more sensor to check the health of patient. Also add of GPS(Global positioning System). For find location of patient in latitude and longtitude. Then location send to doctor by cloud to take action in near hospital. Also Wifi- mesh network for increase the communication range.

Acknowledgment

We expanded gratitude to Department of electrical engineering for work on “**WiFi Enabled IoT Based health Monitoring System**”.Thanks our Project Supervisor **Mr.Vivek Sharma(Assistant Professor,Department of Electrical Engineering, SKIT)**. Give us valuable time from his busy Scheduled and Valuable guidance.

References

- [1] Kumar S, Naryan T, “Wifi Enabled Helath monitoring system” International Journal of Engineering Development and Research(IJDER), Vol 2. Issue 2, pp 238-240, 2019.
- [2] M.M.Vijay and S.C patil “Internet of things” survey of Wifi enabled technology Health care and application, Computer Network, Vol 155, pp 113-133, 2019.
- [3] S Sival, P. Suresh, “WiFi Enabled And Health monitor Survey” IJCTA, 2018 pp 3659- 3663
- [4] WikiPedia “ Purpose of Health monitoring By IoT Based”, 2021.

