



Detection & Distinction of Colors using Color Sorting Robotic Arm in a Pick & Place Mechanism

Dr. K. Venkatachalam¹, G. Sai Sukeshini², B. Nivas³, G. Viswas⁴, P. Akhil⁵

¹Associate Professor, Electronics and communication Engineering Department

^{2,3,4,5}Students, Electronics and communication Engineering Department
Audisankara College of engineering and technology, Gudur

Abstract: Colour sorting Robot is one of the useful, costless and fastest systems in Industrial applications to reduce manual working time and provides less human mistake when manual system is undertaken. The objective of this project is to design an efficient, microcontroller-based system that pick up right color of objects and put it down at right place to optimize the productivity, minimizing the cost of the products and decreasing human mistakes. The controller used is a PIC Microcontroller (18F452) having high speed performance, low cost and 32 K bytes program memory. It communicates with color sensor TCS 3200 and various motor modules in real time to detect the right color object and to control the arm movement. Designed system can pick objects of 1kg weight and arm can rotate up to 360°. Also, the use of easily available components reduces the manufacturing and maintenance costs. The design is quite flexible as the software can be changed according to specific requirements of the user. This makes the proposed system to be an economical, portable and a low maintenance solution for industrial applications.

Keywords: Colour Sorting, Robotics, Motors, Colour Sensor

Introduction

The importance of robotics in 21st century is increasing day by day to reduce human mistakes in their daily tasks because of their ability to do much difficult tasks; the automotive industry fully operates with robots completing tasks on time without any mistake [1]. The "Rancho Arm" was designed in 1963 to assist handicapped persons. Revolution in the robotics has opened the way to help the handicapped people so that they can reclaim the use of lost limbs. By 1969 more robotics arm were developed and controlled through computer such as Stanford arm was robotics arm this respect [2].

The proposed system is an embedded system which will increase the speed of color sorting procedure, provide the accurate color sorting process, decrease the cost of color sorting process and optimize the productivity of an industrial object. The system comprises of color sensor, stepper & servo motors and microcontroller. Color sensor detects the specified color of the object and microcontroller reads this from the data at its input ports. The microcontroller conveys its decision to the station that been programmed. Since a microcontroller is used as a heart of the system, it makes the set up low cost and effective nevertheless. The significance of a project can be estimated from its current utilization and future prospects of advancements. Industry utilization and manufacturing also defined the significance of this project.

Methodology

Color sorting robotic arm is a system having a capability to select the specified color object and placed it at a desired location. Firstly, when object is determined by the robot, the gripper of the robot will pick the object and place it to the specified color differentiating station. The station consists of a color sensor named Light Dependent Resistor (LDR) which detects the light reflected by the body. TCS 3200 is an array arrangement of configurable silicon photodiodes and frequency converter mounted of the chip in the form of a CMOS integrated circuit on RGB color sensor. There is an 8*8 matrix of photodiodes in the sensor i.e. 64 filter sensors are used in it. All these filters are collect RGB (red, green, blue) data from the source [3][4]. The data collected from the sensor is converted into a square wave of 50% duty cycle by an oscillator integrated in the chip. This wave is then sent directly to the microcontroller. Microcontroller transfers signal to the motor drivers to activate the arm to pick the object and drop it to the place defined by programming of controller. The arm rotates to the specific angle (may be 900 , 1200 , 2700 or 3600). The selection of frequency and color is shown in following Tables # 1 & 2. The selection of output frequency is done by terminals S0 and S1, while the color selection task is accomplished by the photodiode output terminals S2 and S3

Flow Chart

The function of robotic arm in the form of flow chart is shown in figure 1. In start robot will take its home position then color sensor detects the object's color with the help of PIC microcontroller. If detected color is true means no specified color object then robotic arm will remain its position. When color is false means desired color is detected then robot will rotate from its position towards object location, drop it to specified place and returns to its original position until other color is detected.

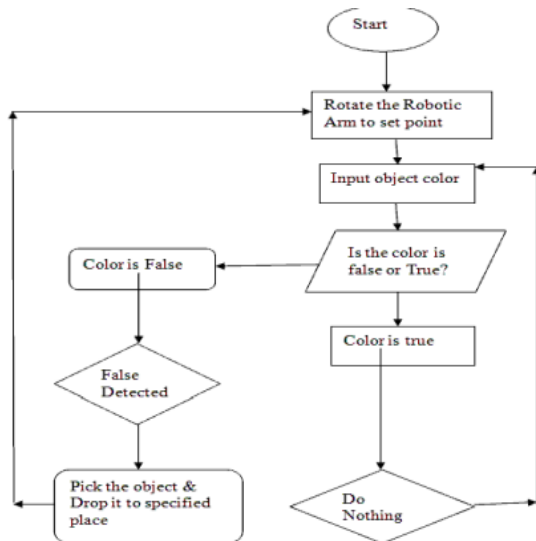

Figure 1: Flow Chart

Mechanical Design of Robotic Arm

Mechanical structure of the robot is constructed on a CNC machine for proper working. The material used in this project is aluminum sheet due to its flexibility and reliability. The design of the robot arm includes four major parts: base, elbow, shoulder and wrist. Different parts of robotic arm with description shown in Figure 2. The robotic arm can be used to achieve the concept of degrees of freedom. Using the robot arm in straight position, rotating it from shoulder side, the robot can move in three different ways. The movement of the robot to up-and-down position is called pitch. The right and left movement is called yaw. Whole movement of the robot arm as a screwdriver is called roll [7].

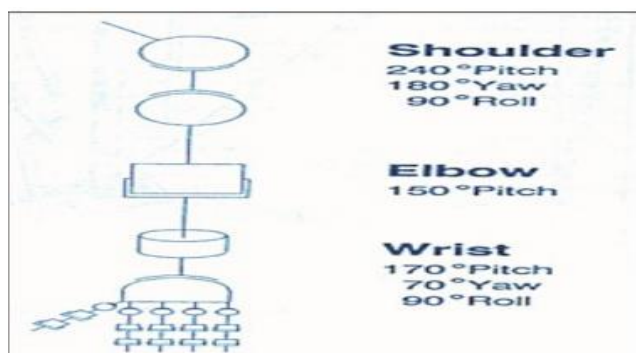

Figure 2: Parts of Robotic Arm [6]

The wrist and shoulder has three degrees of freedom and they are pitch, yaw and roll but elbow has only pitch. Moving the robot arm from the elbow side only, holding the shoulder keeping in same position constantly, the elbow joint has equivalent pitch in the shoulder joint, giving the elbow with one degree of freedom. Now rotating the wrist to straight position and motion less, we can easily bend the wrist to up and down position, side to side and it can easily twist. The mechanical design of robotic arm is shown in Figure 3 below.

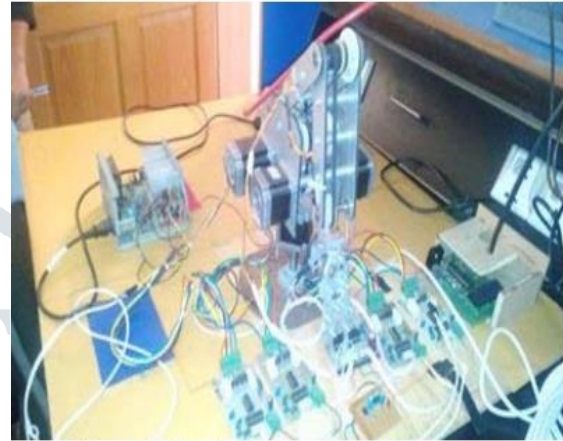

Figure 3: Mechanical Design of Robotic Arm

The lower arm has also three degrees of freedom. Thus the robot arm has seven degrees of freedom. These three degrees of freedom are enough to bring the end of an arm to any point at the workplace [8].

Design and Working

Main Control Unit (MCU)

The main unit contains a microcontroller (PIC18F452), 4 modules of stepper driver, a servo (for grip) and some other components. To provide 5 volts, LM7805 (regulator) is used in the power supply circuit board. Pin number 1 is pulled up by using 1K ohm resistor and also pulled down by using 0.1uF capacitor. Pin number 11 and 32 are connected to VCC (positive potential) and pin number 12 and 31 to the ground (negative potential). The 20MHz crystal oscillator is connected with the pin number 13 of the controller. It produces Clock pulses for the execution of microcontroller instructions. Microcontroller is operated under 5 MHz frequencies. Figure 4 shows the PCB design of Main Control circuit.

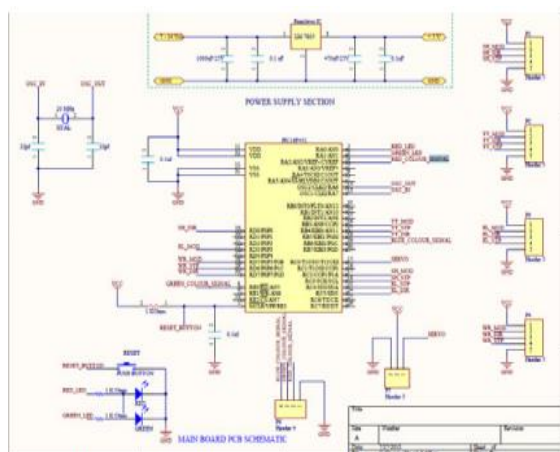

Figure 4: PCB Design of Main Control Board

Four stepper motors were used for controlling robotic arm movements. Each stepper motor is controlled by the stepper driver having L297, 74HC08, four 75NF75 and some other components. Every stepper motor driver has three inputs to control motor with microcontroller. The three inputs of stepper driver which are connected to microcontroller are steps input pin, mode selection pin and direction selection pin. Steps input pin is for rotating of motor. Low to high pulses are given at that pin to rotate the motor rotor. Mode selection is for selection of mode of motor half step or full step mode. Direction selection is for controlling the direction of the motor in clock wise direction or anti-clock wise direction. Servo motor is used for grip motion. The servo motor has 3 pins (i.e. 5V, Signal, Ground). The servo motor is controlled by the timing signal at the frequency of 50Hz signal. If duty cycle of input is 25% then servo will maintain its position in center. If duty cycle is reduced the servo will move 180 degree. Center position of servo will close the grip jaw and when moves 180 degree then, grip jaw will open.

Motor Driver

Motor driver consists of L297, 74HC08 and four Field Effect Transistors which are used for switching as well as amplifying and also provides isolation between circuits [9]. PCB design of motor driver circuit is shown in Figure 5

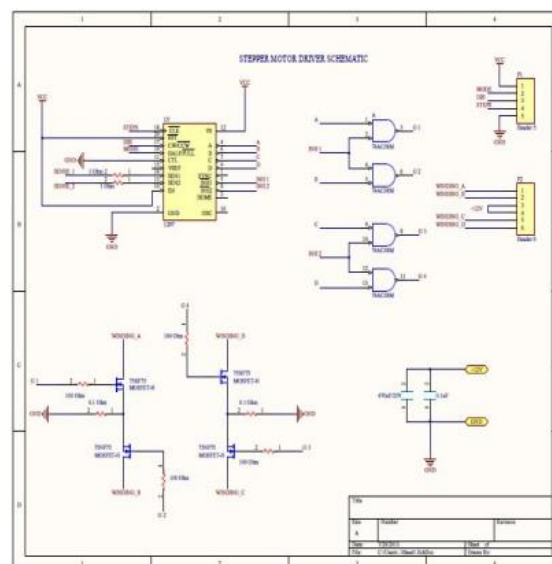

Figure 5: Motor Driver Board

Color Sensing Board

This unit consists of a Microcontroller (PIC18F452), Color Sensor TCS 3200, a Push Button (named GO Button) and some other components [17]. When GO Button is pressed, microcontroller will enable the color sensor to detect the color of placed object on it. Color Sensor TCS 3200 will detect the intensity of Red, Green and Blue in color of the placed object and send it to microcontroller for further process. PCB design of color sensor is shown in Figure 6

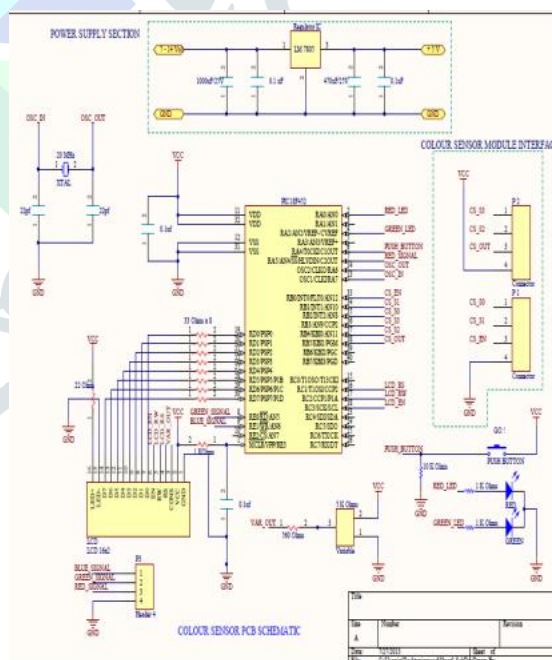

Figure 6: Color Sensing Board

The microcontroller will compare intensity values of red, green and blue to detect the color of placed object. If intensity value of red is greater than green and blue then object's color is red. If intensity value of green is greater than red and blue then object's color is green. If intensity value of blue is greater than green and red then objects color is blue [10]. After detecting color of the object, the microcontroller will give signal from low to high of time

interval of 500 ms and then, low its pin of corresponding color.

Hardware Description

Different components were used in this project. List of the components used in this project are:

Stepper Motors

A brushless, synchronous motor that exchanges digital pulses into mechanical rotation of shaft is called stepper motor. The stepper motor's revolution is divided into a discrete number of steps, almost 200 steps in each revolution and sent a separate pulse for each step. At a time one step can be taken by stepper motor and each step includes the same size. Since each pulse of the step causes the motor to rotate at an angle of 1.8° , the position of the motor can be controlled without any providing feedback mechanism as shown in Figure 7. As the frequency of the digital pulses increases, the movement of the steps also increases causing continuous rotation with the speed of rotation proportional to the frequency of pulses. Due to their low price, high potential torque at low speeds, high reliability and a simple, rugged construction, Stepper motors are used daily in both industrial and commercial applications [11][12].

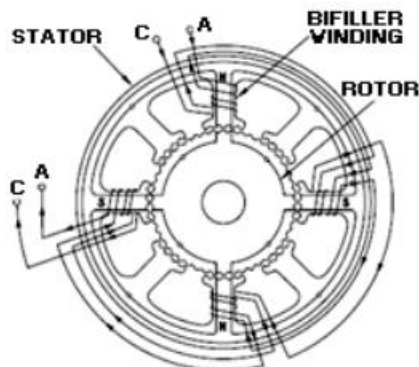

Figure 7: Stepper Motor [11].

Servo Motor

Servo means to an error sensing feedback control that is used for correcting the performance of any type of system. Basically servo motors are DC motors as shown in Figure 8 that are equipped with a servo mechanism for the purpose of controlling precise angular position. These motors usually have a rotation limit ranging from 90° to 180° . But the drawback is that servos do not rotate continually to perform certain tasks. The rotation of these motors is restricted in between the fixed angles. So the Servos are also used for precision positioning. There are most applications where servos are used such as in robotic arms and legs, sensor scanners, RC airplanes etc. [13].

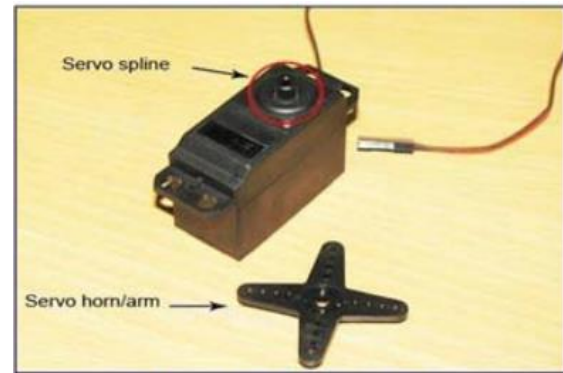

Figure 8: Servo Motor [13]

PIC Microcontroller

In the present day, PIC Microcontrollers are quickly replacing computers when programming robotic devices are considered. PIC micro controller is developed by micro technology in 1975. 18F452 microcontroller has dominated features over the other PIC microcontrollers. It has operating frequency is 40 MHz at DC, Program memory is 32 K bytes and data EEPROM memory is 256 bytes [14].

Color Sensor

The Color sensor is a programmable light-to-frequency converter, it can filter RGB (Red, Green, and Blue) data obtained from source light and convert it to a square wave form having 50% duty cycle with frequency proportional to light intensity. The full-scale output frequency can be measured by one of available three preset values with the help of two control input pins S0, S1 and pins S2, S3 are used to control the RGB filter. Digital inputs and digital outputs allow interfacing with a microcontroller directly. So color of the object's light is calculated by RGB values. The schematic diagram of color sensor is shown in figure 9. TCS 3200 color sensor is chosen for this project due to conversion of light intensity into frequency, programmable color ability and giving full-scale output frequency, direct communication with a PIC microcontroller, power supply can be 2.7 V to 5.5 V, minimum error capability [5][15].



Figure 9: TCS 3200 [16].

Software's

Following are the software's used in the project. 7.1

MPLAB IDE

MPLAB Integrated Development Environment (IDE) is a tool which is used for development of embedded applications for PIC microcontroller series. MPLAB can be used in XP windows; it provides the option for editing program in its editor and to drags the code. It can also be used for single unified graphical user interface for more microchip and 3rd party software and hardware. It has the same user interface for all tools such as flash programming tools and upgrading from the free software simulator to hardware debug is done. [17].

Motor Drivers

There are four motor drivers for each stepper motor to control the speed of these motors. Stepper driver includes L297 IC with H Bridge built-in (automatically generating duty cycle) which is used to control the motor according to instructions giving by Microcontroller [18]

CCS C Compiler

Levelheaded and efficient CCS C compilers comprise touchstone C operators and built-in function libraries that are particular to PIC registers, allow developers with a right tool for accessing device hardware features from the C language level. The CCS code optimizes C compiler supports up to 56K instructions and 4K RAM for these new 14-bit devices. The compiler runs under Windows 95, 98, 2000, XP, Vista, Windows 7 and Linux. It outputs debug and hex files that are selectable and compatible with popular emulators and programmers including the MPLAB® IDE for source level debugging [19].

Conclusion

The system has been successfully designed and it has the capability to rotate 3600 and handle the required task. It can take specific colored object, hold it and put it to a particular station even to some height using RGB color sensor. Color sensing section performed two main tasks; object's detection and color recognition. System is fully remote controlled and can pick objects of 1kg weight

approximately. The cost effective system was designed to perform the continuous and reliable tasks without human errors using the simplest concepts. The robotic sorting systems are useful in industries and different household activities. Since this system is mainly controlled by the PIC Microcontroller, the results obtained are more reliable and faster

Recommendations

The color sorting robotic arm is used to perform the sorting of objects with the help of color sensor. The system can be advanced by increasing the efficiency of color sensor which is the key component of the project used for distinguishing the objects. Selecting the right material for selection of right color sensor to accurately distinguish between different colors. Another area of improvement in this project is a design for using Digital Image Processing (DIP). The ultrasonic imaging, remote sensing, astronomy, medicine, automated industry inspection and space exploration. Image processing can be done by using some image classification algorithms using different spectral features, the brightness, and color information presented in each pixel.

References

- [1] Yeow Khang Yung, "Color Sorting System with Robot Arm" Faculty of Electronic and Computer Engineering University Technical Malaysia Melaka, (2011).
- [2] <http://robotics.megagiant.com/history.html> [3] www.colourtherapyhealing.com/colour
- [4] Alexander Getman, Jinhak Kim, Tae-Chan Kim; Imaging system having White-RGB color filter array' in Proceedings of 2010 IEEE 17th International Conference on Image Processing September 26-29, 2010, Hong Kong.
- [5] <http://www.mouser.com/catalog/specsheets/TCS3200-E11.pdf>
- [6] M. C. Mulder, S. R. Malladi, "A minimum effort control application for Cooperating sensor driven intelligent multi-jointed robotic arm," Proceedings of the 30th IEEE Conference on Decision and Control, vol. 2, pp. 1573–1578, 1991.
- [7] E. Oyama, T. Maeda, J.Q. Gan, E.M. Rosales, K.F. MacDorman, S. Tachi, A. Agah, "Inverse kinematics learning for robotic arms with fewer degrees of freedom by modular neural network systems," International Conference on Intelligent Robots and Systems (IROS), 2005, pp. 1791–1798.
- [8] Malvin Nkomo, Member of SAIEE and Michael Collier "A Color-Sorting SCARA Robotic Arm" College of Information and Electrical Engineering Shandong

University of Science and Technology Qingdao, (2010),
China

[9]http://www.lscsi.com/pdfs/Data_Sheets/LS8397.pdf

[10][http://www.dfrobot.com/wiki/index.php/TCS3200\Color_Sensor_\(SKU:SEN0101\)](http://www.dfrobot.com/wiki/index.php/TCS3200\Color_Sensor_(SKU:SEN0101)) [11]sM.H. Liyanage, N. Krouglicof, R. Gosine, "Design and control of a high Performance SCARA type robotic arm with rotary hydraulic actuators," Canadian Conference on Electrical and Computer Engineering (CCECE), 2009, pp. 827–832.

