



# SELF REGENERATING ELECTRIC GREEN BIKE

Nehal Ahmad<sup>\*1</sup>, Dr. Salim Sharieff<sup>\*2</sup>, Asghar Abbas M.<sup>\*3</sup>, Ayub Ali Khan<sup>\*4</sup>, Mohammed Shahid<sup>\*5</sup>, Syed  
Asadulla<sup>\*6</sup>,

<sup>\*1</sup>Assistant Professor, Department of Mechanical Engineering HKBK College Of Engineering Bangalore, India.

<sup>\*2</sup>Professor & Head, Department of Mechanical Engineering HKBK College Of Engineering  
Bangalore, India.

<sup>\*3</sup>Student Of HKBK College Of Engineering Bangalore, India.

Author for Correspondence E-mail: [nehalahmad25@gmail.com](mailto:nehalahmad25@gmail.com)

## ABSTRACT

The idea of incorporating an electric motor inside a bicycle to help with pedalling has developed over time, giving rise to the contemporary e-bikes that are currently gaining popularity. In addition to a motorised system powered by a battery, this bicycle also has a pedal system similar to that of a traditional bike. Our proposal for a bicycle with a pedal assist and a battery-operated BLDC hub motor was made in response to the issues of rising fuel prices and environmental pollution. The force applied for pedalling is multiplied when the pedal is triggered, and this force much outperforms the actual chain-driven mechanism to propel the bicycle's wheel.

key words : E-bike, electric motor, mechanism, pollution

## I. INTRODUCTION

A double electric motor-powered electric bicycle was created later in 1897 by Boston resident Hosea W. Libbey. In 1990, the Giant Lafree E-Bike brand used the same design. Transportation is the main sector and every other sector depend on it. But the conventional vehicles which we used today uses petrol and diesel but which are non- renewable energy resources. Moreover, these vehicles increase air and noise pollution which is global problem now. This creates the requirement of clean and renewable energy sources. That's why alternating energy sources getting the attention of the world in last few years. Though electric vehicles have many drawbacks many research are going on electrical bikes because of its nature friendly characteristics. Even many nations depend on other countries for petroleum products. The major factors to use our bike are:

- Cutting back fossil fuel use
- Quick and adaptable
- Eco-friendly
- Reduce spending

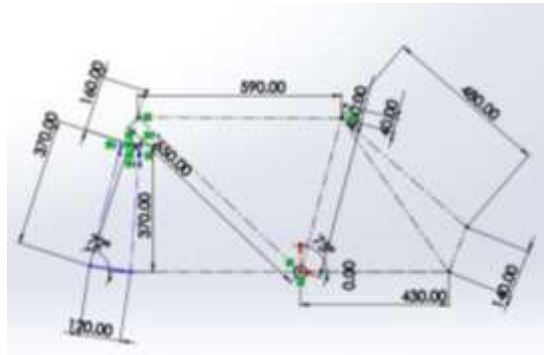

Fig 1: Dimensions of Bicycle frame

## II. LITERATURE REVIEW

The technological and design elements of electric bicycles, such as motor types, battery technology, charging methods, and control algorithms, are frequently the focus of literature on the subject. Studies have looked into the effects of various motor types, including hub motors, mid-drive motors, and crank motors, on the performance of e-bikes. It has also been studied how different battery technologies, such as lithium-ion, nickel-metal hydride, and lead-acid batteries, affect the environment in terms of energy-density, weight, cost, and impact. Studies have also looked into algorithms for control for motor assists and handling of energy in e-bikes, as well as charging systems like solar charging and regenerative braking. The behavior and perception of the rider are further topics of study in the literature on electric bicycles. Studies investigated into how e-bikes impact users' speed, distance traveled, and route preferences. The use of e-bikes has also been studied in connection to factors such rider age, gender, experience, and fitness level. In addition, studies have looked at how users perceive e-bikes, including their views, driving forces, and adoption hurdles, as well as safety issues, social acceptance, and cultural influences on e-bike use. Research has also looked into how electric bicycles affect physical activity and health. Studies have looked into the potential for e-bikes to encourage physical activity and offer health advantages such improved cardiovascular health, mental health, and fitness.

### METHODOLOGY

The Pedal's operation will drive the Gears, which in turn will drive the wheel and initiate forward motion. Aside from that, the Gear mechanism will also power the Regenerating Mechanism, which will create electricity that will be regulated by a voltage regulator and be used to recharge the Battery. This battery will be used by the motor to power the bicycle.

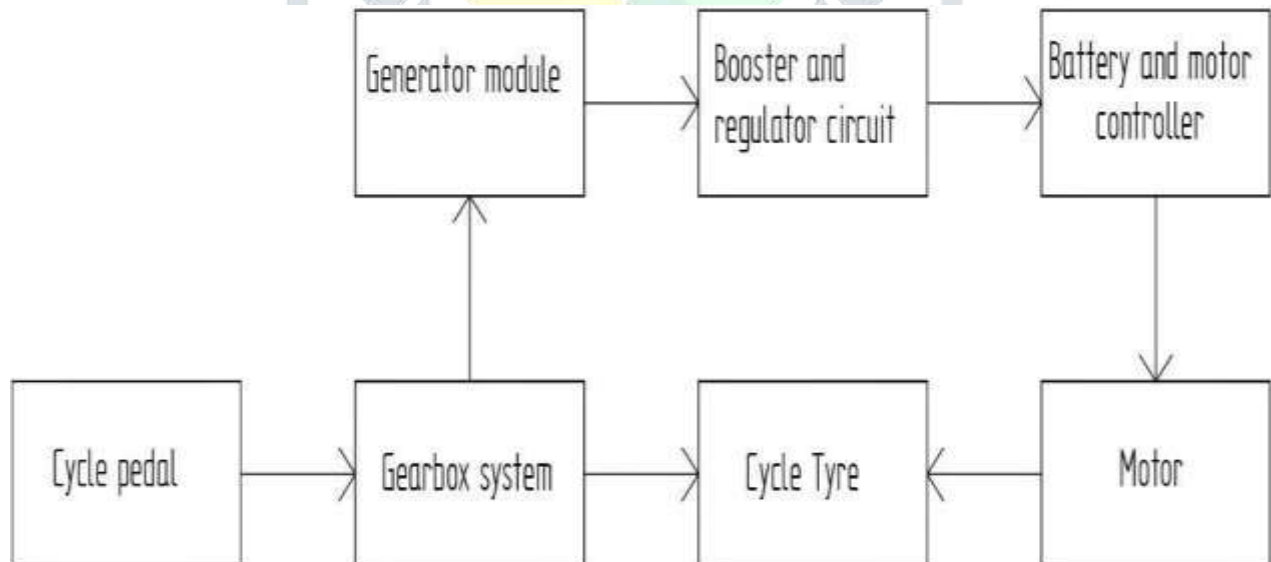

Fig 2: Block diagram of working concept

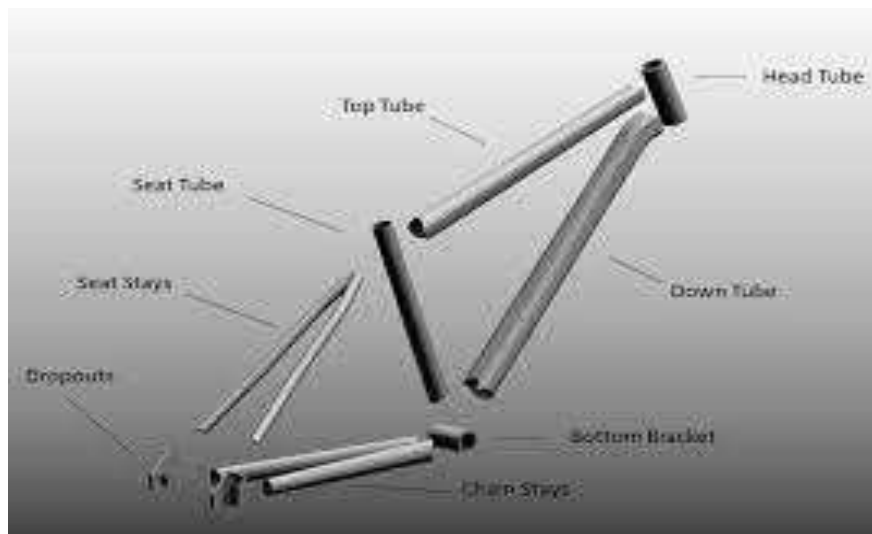

Fig 3: Frame Components

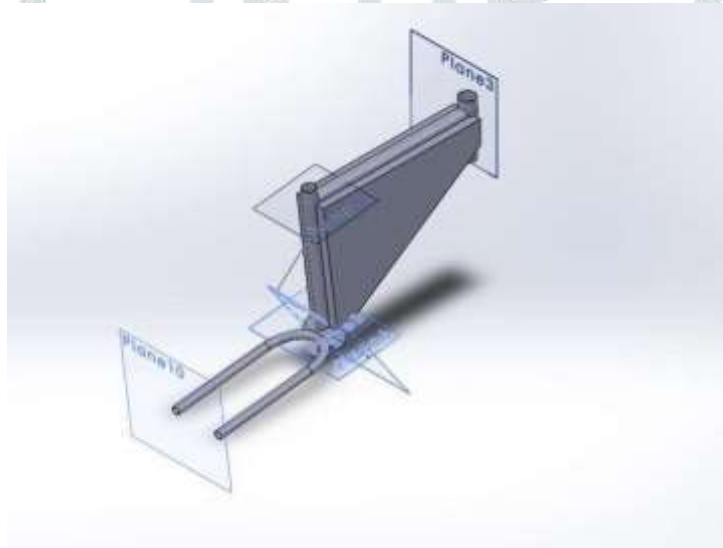

Fig 4: Frame Design iso view

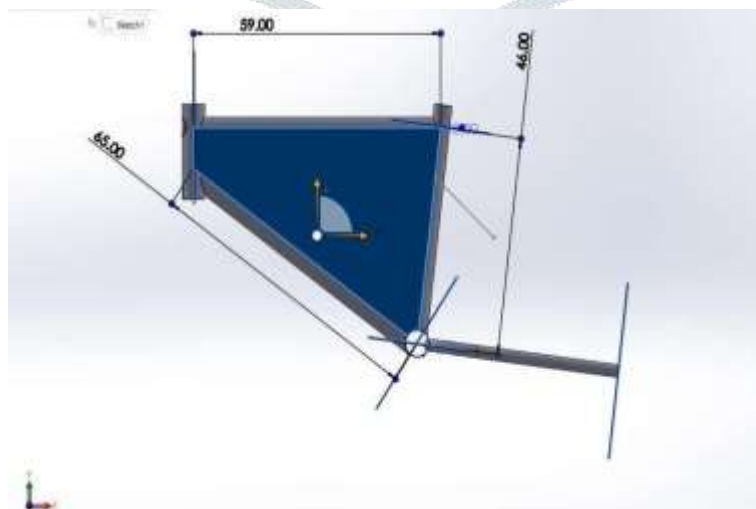

Fig 5: Frame Design Front View

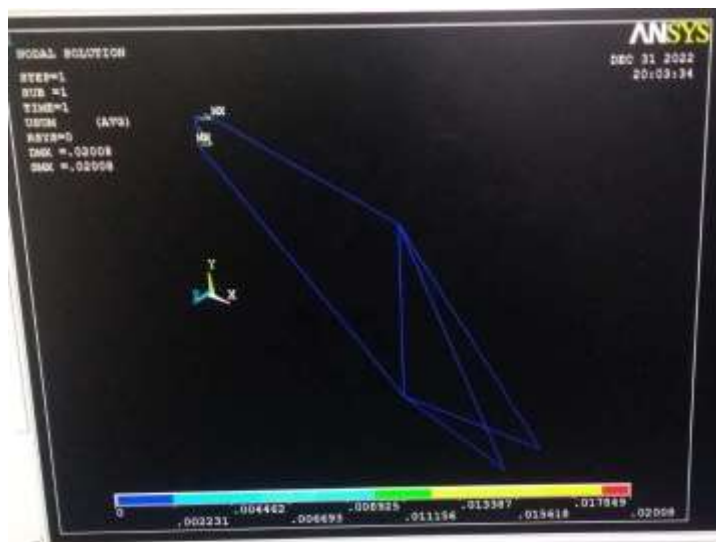
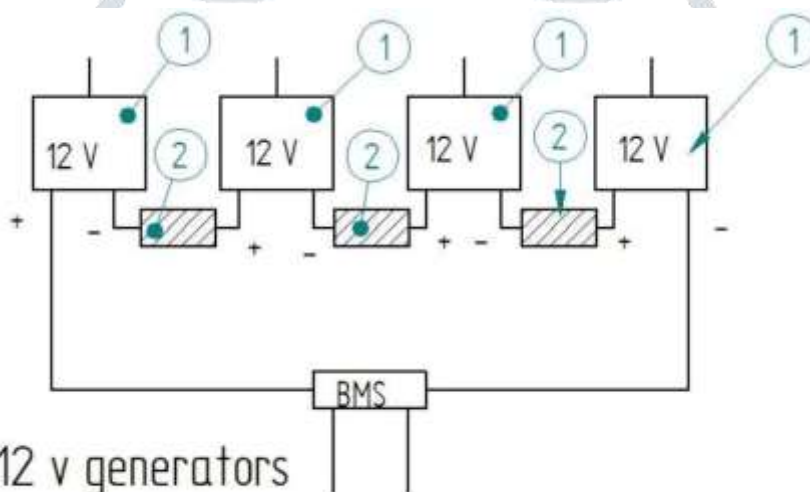

Fig 6: Ansys Analysis of Frame



- 1. 12 v generators
- 2. IN4007 diodes to battery

Fig 7: Block Diagram of Regenerating Mechanism



Fig 8: Gear Set



**Fig 9:** CAD model of Gear Mechanism



**Fig 10:** Fabricated Hub Motor and Gear on Rear Wheel



Fig 11: Fabrication of Battery



Fig 12: Final Model

### III. COMPONENTS USED

Due to its excellent mechanical and machining capabilities, mild steel is used for the construction of bicycles as well as the front and rear gear sets.

#### 1. Frame:

In accordance with the measurements of the most common B'Twin bicycle frames. When creating the frame, consideration is given to the frame size. The amount of clearance needed to reduce frictional and fit the power source and motor controller depends on the frame dimensions, available space, and other factors. as depicted in Figure 1.

#### 2. BLDC Hub Motor:

A 350W BLDC hub motor along with a 36/48V Controller which are available in the market are used along with their complementary available items.

#### 3. Shaft:

Mild steel is typically utilised to fabricate shafts or rods. Two distinct shaft sizes are employed to accommodate different bearing types. The load-bearing parts of the gear mechanism, the bearings, also aid in the simple meshing of the gear set because they only make line contact, which lowers wear and reduces the amount of effort needed to move the gears.

4. **26-inch wheel:** The vehicle's front wheel is attached to the 26-inch (660.4mm) wheel, and the specifics are depicted in the figure.

### IV. RESULT AND DISCUSSION

#### Discussion:

- [1] The traditional bicycle system, which consists of a chain and sprocket configuration, could be replaced with this chainless cycling system.
- [2] This chainless bicycle can be successfully operated by substituting a motor shaft for the chain ring.
- [3] This chainless bicycle technology was designed for effortless, quiet power transmission.
- [4] A chainless bicycle system uses a drive shaft that is optimally built and uses bearings, bevel gears, and shafttrods in place of a chain drive that uses chains and sprockets..
- [5] Off-road racing would be incredibly pleasant with this chainless bicycle system.
- [6] This chainless bicycling system has a relatively long lifespan and needs little maintenance.

#### Results:

- [1] The Chainless Bicycle System was designed with calculations.
- [2] The theoretical research indicated that this chainless bicycle system's design was safe.
- [3] When put under different weights, the Chainless Bicycle System, which uses a shaft-drive mechanism, is secure.
- [4] The Chainless Bicycle System utilises a drive shaft that is lightweight, has bevel gears on both ends, and minimises energy loss.
- [5] For a trouble-free and superior transfer of power, the chainless bicycle system with driveshaft system is designed and manufactured.

### V. MATHEMATICAL FORMULATION

#### Design calculations Length of the platform:

Let us assume, the mass of rider = 80 kg

1. Shaft's Inner Diameter ( $d_i$ ) = 24mm = 0.024m
2. Shaft's Outer Diameter ( $d_o$ ) = 26mm = 0.026m
3. Length of Shaft (L) = 420mm = 0.420m
4. Torque Produced (T) = Rider mass \* g \* shaft length
 
$$= 80 * 9.81 * 0.420$$

$$= 329.616 \text{ Nm}$$

$$= 329.616 \text{ Nmm}$$

5. Polar moment of inertia (J) =  $\pi (d_o^4 - d_i^4) / 32$ 

$$= \pi [(0.026)^4 - (0.024)^4] / 32$$

$$= \pi (9.752 * 10^{-8}) / 32$$

$$= (3.9125 * 10^{-9}) / 32$$

$$= 1.22914812610^{-8} \text{ m}^4$$

6. Power (P) =  $2\pi NT / 60$   
 $= 2\pi * 100 * 329.616 / 60$   
 $= 207103.8408 \text{ W}$
7. Shear Stress ( $\tau$ ) =  $T_p / J = (329.616)(7800) / 1.22914812610^{-8}$   
 $= 1.34^7 \text{ N/ m}^2$
8. Maximum Shear Stress ( $\tau_{max}$ ) =  $TR_o / J$   
 $= (329.616)(0.012) / 1.22914812610^{-8}$   
 $= 20.61 \text{ N/ m}^2$

#### Front Gear Set Calculation

Module is the term or says unit used to show the size of gears. It is equal to the ratio of the reference diameter of the gear to the total number of teeth. It is shown by 'm' & the unit of size.

Module (m) = Gear reference diameter/ no. of teeth Or,

$$m = d/z$$

Let, Module (m) = 4

Pressure Angle ( $\alpha$ ) = 20 degree On

Pinion, no. of Teeth ( $Z_p$ ) = 24 On Gear,

no. of Teeth ( $Z_g$ ) = 44 Pitch Circle

Diameter (D) =  $m * Z$

Pinion pitch circle diameter ( $D_p$ ) =  $4 * 24 = 96 \text{ mm}$  Gear

Pitch Circle Diameter ( $D_g$ ) =  $4 * 44 = 176 \text{ mm}$  Addendum

( $h_a$ ) = module (m) = 4 mm

Dedendum ( $h_d$ ) =  $1.25m = 1.25 * 4 = 5 \text{ mm}$

Clearance (c) =  $0.25m = 0.25 * 4 = 1 \text{ mm}$  Working

depth ( $h_w$ ) =  $2m = 2 * 4 = 8 \text{ mm}$  Whole depth (h) =

$2.25m = 2.25 * 4 = 9 \text{ mm}$

Thickness of Tooth (s) =  $1.5708m = 1.5708 * 4 = 6.28 \text{ mm}$  Tooth

Space =  $1.5708m = 1.5708 * 4 = 6.28 \text{ mm}$

Fillet Radius =  $0.4m = 0.4 * 4 = 1.6 \text{ mm}$

#### Rear Gear Set Calculation:

Module (m) = 4 Pressure

angle ( $\alpha$ ) = 20

Degree On Pinion, no. of Teeth ( $Z_p$ ) = 24 On

Gear, no. of Teeth ( $Z_g$ ) = 24

Pitch Circle Diameter (D) =  $m * Z$

Pinion pitch circle diameter ( $D_p$ ) =  $4 * 24 = 96 \text{ mm}$  Gear

pitch circle diameter ( $D_g$ ) =  $4 * 24 = 96 \text{ mm}$

Addendum ( $h_a$ ) =  $m = 4 \text{ mm}$

Dedendum ( $h_d$ ) =  $1.25m = 1.25 * 4 = 5 \text{ mm}$

Clearance (c) =  $0.25m = 0.25 * 4 = 1 \text{ mm}$  Working

depth ( $h_w$ ) =  $2m = 2 * 4 = 8 \text{ mm}$  Whole depth (h) =

$2.25m = 2.25 * 4 = 9 \text{ mm}$

Thickness of Tooth (s) =  $1.5708m = 1.5708 * 4 = 6.28 \text{ mm}$  Tooth

space =  $1.5708m = 1.5708 * 4 = 6.28 \text{ mm}$

Fillet radius =  $0.4m = 0.4 * 4 = 1.6 \text{ mm}$



## VI. CONCLUSION

The project's multiple results are listed below, along with its general conclusion:

- [1] The traditional bicycle system, which consists of a chain and sprocket configuration, could be replaced with this chainless cycling system.
- [2] This chainless bicycle can be successfully operated by substituting a motor shaft for the chain ring.
- [3] This chainless bicycle technology was designed for effortless, quiet power transmission.
- [4] This chainless bicycle system uses a drive shaft that is optimally built and uses bearings, bevel gears, and shaft rod in place of a chain drive that uses chains and sprockets.
- [5] Off-road racing would be incredibly pleasant with this chainless bicycle system.
- [6] This chainless bicycle system has a relatively long lifespan and needs little maintenance.

## REFERENCES

- [1] Patent No.: US 2022/0315164 A1, "ELECTRICALLY-ASSISTED PEDAL CYCLES" dated October 6 2022. Invented by Linan Gong.
- [2] Patent No.: US 11352097 B2 "HYBRID POWERTRAIN FOR A PEDAL VEHICLE, CONTROL UNIT THEREFORE, PEDAL VEHICLE" dated June 7 2022. Invented by Tomas Bernard Guy Keppens.
- [3] Patent No.: US 11260936 B2 "GEARLESS POWER CONVERSION SYSTEM EMPLOYING TWO ELECTRIC MACHINES" dated March 1 2022. Invented by David Calley and Steve Purcell.
- [4] Patent No.: US 10, 899,224 dated January 26, 2021. Applicant Name: Razer LLC. Invented by Joey Chih-Wei Huang.
- [5] Patent No. : US10358133 B2 dated July 23 2019. Applicant Name: Civilized cycles, Inc. Portland (U.S.). Invented by Zachary Schieffelin.
- [6] Patent No.: US 2019/0039451 A1 dated February 7 2019. Applicant Name: Geo orbital Inc. (U.S.). Invented by Michael Burtov, Dakota Dekker, and Gideon Coltof.
- [7] Adithya Kumar, Srirenga Venkatesh, Satheesh Kumar, Pragatheeshwarar "FABRICATION OF SELF-CHARGING ELECTRIC BIKE" International Journal of Pure and Applied Mathematics Volume 118 No. 22 2018
- [8] Shubham U. Tayde, Neha W. Makode, Umesh M. Laybar, and Prof. Bhushan S. Rakhonde "SELF POWER GENERATING ELECTRICAL BICYCLE" International Research Journal of Engineering and Technology
- [9] Richard Craven, James Lloyd, Jonathan Mundy, Bruce Southey, Simon Potticary, James Neugebauer, Torsten Gerhardt, "ELECTRIC BICYCLE" US Patent Office, dated May 30 2017 Uploaded on patents.google.com. Patent No.: US 9663177 B2
- [10] Yogesh Jadhav, Gaurav Kale, Shekhar Manghare, Sager Patil "Self Charging Electric Bicycle" International Journal on Recent and Innovation Trends in Computing and Communication ISSN: 2321-8169 Volume: 4 2017
- [11] Philip Tomkinson and Dr. Birmingham Taylor "BICYCLE DESIGN" US Patent Office, dated March 3 2016, Uploaded on patents.google.com. Patent No. 4647060.
- [12] Bruce Southey, "FOLDING BICYCLE" US Patent Office, Uploaded on patents.google.com. Volume: US 2016/0031506 A1.
- [13] "Design and Fabrication of Self Charging Electric Vehicle" By M. Sathya Prakash International Journal of Power Control Signal and Computation (IJPCSC) Vol 8. No.1 – Jan-March 2016
- [14] "Self-Generated Electric Bicycle" by Prof. S.H. Shete, Nitin Patil, Ganesh Khot, Kiran Kokitkar, Santosh, Vardapgol, Jayashri Sawant, INTERNATIONAL JOURNAL OF INNOVATIVE RESEARCH IN ELECTRICAL, ELECTRONICS, INSTRUMENTATION AND CONTROL ENGINEERING Vol. 4, Issue 3, March 2016

- [15]Patent No.: US 2012/0169154 A1 “AXIAL-FLUX BRUSHLESS ELECTRIC MOTOR” dated July 5 2012. Applicant name: ODOMOTION, Inc. St. Nicholas (LA). Invented by: Alain Curodeau.
- [16]“Electric Bicycle System” By Robert Cong, Rodney Martinez, Mark Casilang ,Peter Vong, California Polytechnic State Ilyas Hussain University San Luis Obispo June 2010
- [17]Patent No.: US 2009/0058374 A1 “HIGH EFFICIENCY ALTERNATOR” dated March 5 2009. Invented by Thomas Evans and Derrich Neice.
- [18]Patent No.: EP 1982909 A1 (European Patent) “COMBINATION OF BICYCLE AND FRAME” dated April 20 2007. Invented by Lai and Chih-Hsiung
- [19]Patent No.: 3921741, “BICYCLE WITH ELECTRIC MOTOR ASSIST” dated November 25, 1975. Invented by Irwin P. Garfinkle and Robert J. McNair
- [20]John Taylor “BICYCLE” US Patent Office, Uploaded on patents.google.com. Patent No. 684882

