



## PREPAID ENERGY METER

Shakthi Anbazhagan M<sup>1</sup>, Shashank S<sup>2</sup>, Shiva Reddy B A<sup>3</sup>, Shreyas M S<sup>4</sup>,

Mr. Praveen A<sup>5</sup>

Student, ECE, KSIT, Bengaluru, India<sup>1-4</sup>

Guide, Associate Professor, ECE, KSIT, Bengaluru, India<sup>5</sup>

### ABSTRACT:

The aim of the paper is to minimize the queue at the energy meter billing counters and to restrict the usage of energy meter automatically, if the bill is not paid. The project also aims at proposing a system that will reduce the loss of power and revenue due to power thefts and other illegal activities. This technology holds good for all electricity distribution companies, private communities, IT parks and self-containing housing projects. The implementation of this paper will help in better energy management, conservation of energy and in doing away with the unnecessary hassles over incorrect billing. The prepaid card communicates with the power utility using GSM communication network. Once the prepaid card is out of balance, the consumer load is disconnected from the utility supply by the latching Relay (contactor). This paper demonstrates the use of prepaid energy meter system. If we use this system, it will be beneficial for the consumer to manage power. It is easy to operate and cost effective. Another advantage of the prepaid system is that the human errors in taking meter readings and processing bills can be largely reduced.

**KEYWORDS:**-Prepaid, Energymeter, GSM module.

### 1. INTRODUCTION

In recent years many attempts have been made to design the energy meter with instant billing technique but till now the designed energy meters are not efficient and do not provide replacement. Now a day the number of electricity consumers is largely increasing. It is hard to handle and maintain the power due to growing requirements. Maintenance of the power is an important task as the human operator goes to consumer's house and takes the meter reading and based on this reading produced the bill amount for this month in which electricity consumed by the

customer. The billing process takes a lot of time if the consumers are not in the house while reading of energy consumption and generating the bill. If the consumer did not pay the bill, the Electricity Board people need to go their house to disconnect the power supply. This consumes time and is difficult to handle. The manual operator cannot find the Unauthorized connections or malpractices carried out by the consumers to reduce or stop the meter reading/power supply. Some of the energy meters which had been implemented are prepaid but it needs a Smart card to recharge it. The major disadvantage of that method is that it needs internet and the computer interface. In this paper we propose a method which uses GSM Network which eliminates the need for the internet. "GSM Based Prepaid Energy Meter" system consists of Energy Meter and the GSM Network. The system provides efficient

power meter reading, usage notification and consumers maximum demand using GSM network. GSM modem utilizes the GSM network to send equivalent unit for the recharge amount to the Microcontroller and send message to the customers also. The message consists of details of energy required to the customers in the terms of the unit.

## II.LITERATURE SURVEY

Ajay Mahato et al. [1] This paper has implemented electric power theft detection and location tracking using IoT. The main aim is to reduce power theft. This proposed system claims to detect power theft in real time, along with location of theft. The system will have an online database. The heart of this project is Arduino UNO controller. In this system the location of the theft is determined. The system can be further improved in future because of its high usage factor, we can detect the theft of power more precisely.

Shreya Lokhande et al. [2] This paper has proposed electro-mechanical meter with motorized nature of the segments utilized in many regions ruin due to long usage. These meters were later substituted by digital energy meter having high precision and accuracy with LCD display. Evolution in this pathway includes AMR using digital energy meter. There are diverse technologies being utilized for ARM using Bluetooth, GSM, GPRS, Zigbee, PLC, RFID and so on. design of such meters based on BT, GPRS may direct to network uncertainty; with GSM, instantaneous invoice might lead to loss of message. Although problems may arise due to errors caused by meter reader, it is also time consuming and requires human labor.

K.Prahalada Rao et al. [3] This paper has proposed a digital meter whose blinking LED signal is interfaced to microcontroller through LDR the blinking LED flashes 3200 times for 1 unit the LDR sensor gives an interrupt each time the meter LED flashes to the programmed microcontroller, microcontroller takes this reading and displays it on LED duly interfaced to the microcontroller. The reading of the energy meter is also sent to Ethernet shield module being fed from the microcontroller via level shifter IC and RS232.

Geetha R. M et al. [4] This has implemented monitoring and keeping track of electricity consumption. In this method we are using Arduino because it is energy efficient, it consumes less

power. The advantages are efficient use of energy, less labor cost, they know exactly how much power is being utilized, no need to wait for the month end bill. Remote access of meter reading the propagated model is used to calculate the energy consumption and make the energy unit reading to be handy and has been made to make a practical model of IoT based smart energy meter. It is used to calculate energy consumption. The proposed system is designed in such a way to avoid the limitations of the existing system. It provides more flexibility, comfortability and security. It also reduces the wastage of energy and brings awareness.

Anshu Singhal et al. [5] In this paper the system proposed the IoT technology is used to detect the theft of electricity. The power transferred and the power consumed is measured and the difference is used to detect the theft of power. Security is automated and hence the economy of the country is saved. Alerts can be generated through GSM even in the case of failure of internet. This system is used in distribution systems and in AMR. As further implementation to the developed model we can assemble GPS module to identify exact location of power theft.

Subba Rao et al. [6] This has implemented Arduino because it is energy efficient. The consumer is facing problems like receiving due bills for bills that have already been paid as well as poor reliability of electricity supply and quality even if bills are paid regularly. The propagated model is used to calculate energy consumption, reducing the wastage of energy. Arduino is used in this method because it is energy efficient, it consumes less power and deducts manual intervention. The propagated model is used to calculate the energy consumption of the household and even make the energy unit reading to be handy, reduce wastage of energy and create awareness.

Vishal Devaliya et al. [7] In this paper a new concept of energy meter where maximum demand of energy of a consumer will be indicated in the meter used by the Consumer. After crossing the limit, the meter and the connection will be automatically disconnected by an embedded system inserted in the meter itself. The system proposed mainly focuses on the usage of electricity by consumers. The system provides restrictions on the usage of electricity when the consumer reaches its limited usage. The limitation on the usage has been set on the system and the limit can be changed accordingly.

Mitali Nagvekar et al. [8] In this paper the authors discuss the concept where the meter reading can be displayed on the VB Application to the service provider and for consumer Android App is designed through which the bill is calculated, and a message is sent to the user. In this system the user can monitor only monthly reading from the Android application and can track the monthly bill through message only. This system does not provide any bill payment method through the application.

Annapurna Mishra [9] In this paper the authors discussed the GSM modem that utilizes the GSM network to deliver the equivalent unit for the recharged amount to the Arduino and alerts the consumer about low balance. In this system if the balance goes below the threshold value, then the relay cuts off the power supply.

Sahana Y M et al. [10] this paper focuses on building an automatic system using Arduino and GSM module where recharge for electricity balance can be done through this system by sending SMS Arduino ATmega328 microcontroller is used. GSM modem is used to send and receive messages.

### III. PROPOSED METHODOLOGY

This section discusses in detail the description of the work done, modelling and the design of the proposed system. Figure 1 depicts the functional block diagram of the smart prepaid energy meter for energy theft detection. This shows how the various components are interlinked.

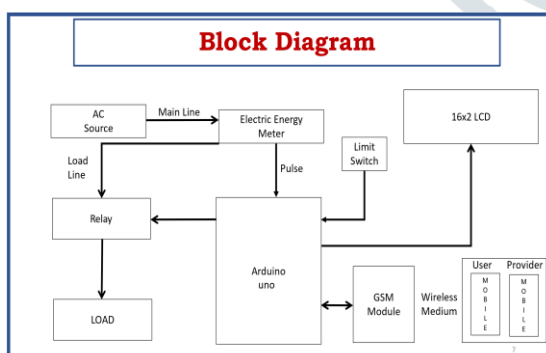

Fig 1: Functional block diagram of proposed model

Here we have interfaced an electricity energy meter with Arduino using the pulse LED (Calibration or Cal) of electricity energy meter. We only need to connect this CAL LED to Arduino through an optocoupler IC. When we power up the system then it reads previous values of rupees stored in EEPROM and restores them into the variables then

checks the available balance with the predefined value and act according to them, like if available balance is greater than 15 rupees then Arduino turns on the electricity of home or office by using relay. And if the balance is less than 15 rupees then Arduino sends an SMS to the user phone regarding low balance alert and requesting to recharge soon. And if balance is less than 5 rupees then Arduino turns Off the electricity connection of home and sends an SMS to user's phone for 'Light Cut' alert and requesting to recharge soon. GSM module has been used to send and receive messages.

### IV. WORKING

The power is measured by the energy meter with respect to time and is calculated by multiplication of voltage and current signals. The IC of the energy meter generates pulses according to real power utilization. This energy meter calculates 1KWh for 3200 impulses, so rated as 3200imp/KWh, and there will be blinking of an LED for its every pulse. An Optocoupler has been connected to this LED so Optocoupler will be switched whenever LED blinks. We cannot directly connect the energy meter's LED with Arduino because LED possesses analogue signals while we are feeding Arduino on the digital side. The pin number(D8) of Arduino is attached to the switching side of an Optocoupler for detecting pulses coming from the energy meter. When a pulse occurs from energy meter, optocoupler is switched, pin D8 of Arduino detects a digital 0, otherwise it is not active and is in undefined state. There will be a count 1 to a data when there will be change on the state of the pin from digital 1 to 0. We have interfaced GSM module with Arduino UNO. The data communication pins are RX and TX, Arduino's RX pin relates to GSM module's TX pin and vice versa. Before connecting GSM module with Arduino, a valid SIM card must be installed in SIM card port of GSM module. All ground pins GND are connected. For switching purpose (ON/OFF) to supply a relay is being used. We cannot connect Arduino directly with relay because as Arduino has ATMEGA328P processor and its pins can supply roughly 25mA, Processor pins have large effective resistance, and a high voltage will "drop" as increasing current is drawn and a low voltage will rise as load increases. Pins may be specific with a maximum short circuit current but at that point a

high pin will be pulled low, and a low pin will be pulled high so short circuit current has limited applicability. So, relay relates to Arduino through ULN2003 IC or relay driver, ON/OFF instructions are sent over to relay driver by Arduino, and it can turn ON/OFF relay. LCD is also interfaced with Arduino digital pins (7, 6, 5, 4, 3, 2) on which we can see how many units are purchased, remaining units and balance, etc.

**Protection against meter tampering** - Consumers or professional ones may try to open the energy meter and tamper it to show low or no energy consumptions. To get rid of this problem, one Switch is used at the opening side of the proposed energy meter. Output of Switch is connected to external interrupt pin of the Arduino UNO. In normal conditions, the Switch will be closed, and the Arduino UNO will detect 5V at its external interrupt pin. If consumer tries to open the energy meter, the Switch will be opened and the Arduino UNO will detect 0V at its external interrupt pin. If this occurs, the Arduino UNO immediately notifies the server and disconnects the load from the supply.

## V.ADVANTAGES/DISADVANTAGES/APPLICATIONS

### Advantages:

- It is highly accurate as of the whole idea of reading the units and then billing manually or any other means is eliminated.
- The consumer cannot escape from paying the electricity bill and the State Electricity Board gets free from debts.
- On the consumer front, the tedious task of paying the bill and waiting anxiously for the bill is eliminated.
- Wastage of energy is diminished as now only the required energy will be consumed as allotted.
- The power grid can monitor the overall energy consumption and any tampering attempts are of no use and can be detected if still prevalent.

### Disadvantage:

- Smart meters communicate with energy suppliers using mobile technology (network coverage) and a weak signal can disrupt this connection.

### Applications:

- At customers' premises for billing purposes.
- It is useful in Industrial applications.
- State estimation of power distribution networks.

## VI.CONCLUSION

The advancement in power distribution system is non-stop process and new technology is always in progress. In this paper, an Arduino and a GSM based smart prepaid energy meter has been proposed. Units are purchased by using GSM technology and those units are deducted according to electricity usage. This project presents a single-phase energy meter for domestic consumers with prepayment billing method. The significant preferred standpoint is the capacity of this system to update the current conventional meters into smart prepaid meters with a connection of Arduino and GSM (Prepaid Module). This kills the need of totally supplant the energy meters. Cost is the main important factor of this work which is quite high but will reduce from 3 to 4 times after implementation of this project. Nowadays as power supply companies need labour for meter reading after implementing this, there will be no need of so many meter readers and lots of money will be saved.

After having many advantages, this project still needs more safety check and modification especially the GSM module for the network coverage of SIM, which is being used, should be strong so that the GSM can work properly.

## VII.REFERENCE

- [1] Ajay Mahato, Abhishek Nanda, "Electric power theft detection and location tracking using IoT," IJSRCSEIT, vol. 4, no. 5, March 2018.
- [2] Shreya lokhande, "IoT based smart electricity meter and power Theft detection," IRJET, vol. 5, no. 1, January 2018.
- [3] K. Prahalada Rao, "IoT Based electricity energy meter reading through internet," IJITMES, vol. 3, no. 11, Nov. 2017.
- [4] Geetha R. M. E, "IoT based smart energy meter," 2018.
- [5] Anshu Singhal, "Electric power theft detection using IoT," IJSRCSEIT, vol. 4, no. 5, April 2018.
- [6] Subba Rao, "IoT based smart energy meter billing monitoring and controlling the loads," IJITEE, vol. 8, no. 4, March 19.

[7] Vishal Devaliya, Ajaysinh Chauhan, Feni Faldu, Kapishwar Mishra, Sourav Choubey “Literature Review on Smart Energy Meter”, International Journal of Innovative Research in Science, Engineering and Technology, Vol 7, Issue 12, December 2018.

[8] Mitali Nagvekar, Megha Mane, Sandip Zade “Automatic Energy Meter Reading System Based on IOT”, International Conference on Innovative Research in Science, Engineering and Technology, Vol. 7, Issue 12, December 2018.

[9] Annapurna Mishra, Avinash Kumar, Chetan Chaturvedi, Gautam Kamran Ravi Kumar “Prepaid Electricity Meter Using GSM Module”, International Journal Of Advance Research and Development, Volume 3, Issue 2.

[10] Sahana Y M1, Shruthi H2, Kavya D P3, Abhishek B C4, Pruthviraja L5. 2017 ‘Prepaid Energy Meter Using GSM Technology.

[11] Uzair Ahmed Rajput, Khalid Rafique. 2018 ‘Modeling of Arduino-based Prepaid Energy Meter using GSM Technology’ [Vol. 9, No. 5, 2018]

[12] Vishal Devaliya, Ajaysinh Chauhan, Feni Faldu, Kapishwar Mishra, Sourav Choubey “Literature Review on Smart Energy Meter”, International Journal of Innovative Research in Science, Engineering and Technology, Vol 7, Issue 12, December 2018.

[13] Gopal, Devendra Kumar Pandey, Brijesh Kumar Dubey “Prepaid Energy Meter with GSM Technology”, JETIR March 2019, Volume 6, Issue 3.

[14] Visalatchi S., Kamal Sandeep, K., (2017). Smart energy metering and power theft control using arduino & GSM, 2nd International Conference for Convergence in Technology, I2CT, IEEE, India.

[15] Kumar A., Thakur S., & Bhattacharjee P., (2018). Real time monitoring of AMR enabled energy meter for AMI in smart city-an IoT application, IEEE International Symposium on Smart Electronic Systems (iSES) (Formerly iNiS), IEEE, India.