

COMPANIONABILITY OF MODIFIED Z – SOURCE INVERTER WITH SOLAR POWER GENERATION FOR A 3Ø-ASYNCHRONOUS MOTOR

Dr.Arulprakash Andigounder¹

Professor/EEE, Bharat Institute of Engineering and Technology, Hyderabad, India

Vijayalakshmi Yarra², Dhanalakshmi Malothu³

PG Student/EEE, Bharat Institute of Engineering and Technology, Hyderabad, India

ABSTRACT -Among the different types of inverters for the solar power generation, the impedance source (Z-Source) inverter finds a significant role due to its boosting characteristics. Since the source for this proposed work is solar energy, the inverter with impedance will give a sufficient level of voltage for the load. The output of the proposed is given to a three phase asynchronous type of motor, which is commonly used by the farmers in their agricultural pumps. Even though the inverter is working under heavy stress due to the output of the Z-Source, necessary filter arrangement is made to get smooth alternate energy for running the motor. The entire arrangement is modeled using MATLAB/SIMULINK and the results are analyzed with the help of THD (Total Harmonic Distortion) values of output voltage and current.

KEYWORDS- Solar energy, Z-Source inverter, asynchronous motor, Total Harmonic Distortion

INTRODUCTION

Nowadays the thirsty for power has increased manifold due to the enormous growth in industries and population. But the resources of traditional or conventional power have been drastically reduced and they may be available for four or five decades of future. Also the abundant use of conventional or non renewable energy resources, various environmental problems like air pollution, water pollution etc have increased and all become a intimidation for the whole human society. Hence the searching for alternate energy has become a timely needed one. Among the various renewable energy sources like solar, thermal, hydro, biomass and wind energy, the solar energy is the most promising one among them. Solar energy is a radian light and heat from the sun that is harnessed using a range of ever-evolving technologies such as solar heating, photo-voltaic, solar thermal energy, solar architecture, molten salt power plants and artificial photo synthesis. The large magnitude of solar energy availability makes it a highly appealing source of electricity. The United Nations development programme in its world energy assessment found that the annual potential of solar energy was 1600 to 50000 exa joules [EJ]. This is several times larger than the total world energy consumption which was 559.8EJ in 2012. The benefits of renewable energy resources reduce the pollution, lower the costs of mitigating global warming & keep fossil fuel prices lower. These advantages are global. Solar energy has the greatest potential of all the sources of renewable energy.

Also the farmers in our country are facing power problem for their agricultural pumping motors moreover in all seasons in all states. Moreover the price per unit cost of the power also has become a burden for the farmers.

Hence the proposed work aims in harnessing solar energy in a prominent way, which will help the farmers and the environment. In this work, an asynchronous machine is made to run by using solar energy with the help of PWM techniques and a 3-phase inverter. The solar energy is dynamic nature, but it is necessary to give a continuous supply for the motor even the solar energy is not inadequate. In this work the solar energy generated by the solar panel, is stepped up by using impedance network. Generally the Z-source network consists of two inductors and two capacitors. In the modified Z-source network, in addition to two capacitor, one capacitor is added parallel to the source. Added capacitor boosts the voltage from the source and also acts as filter. The hardware results are validated with the analysis of total harmonic distortion of output voltage and current of the three phase inverter.

PROPOSED SYSTEM

The proposed system with Modified Z-source inverter is shown in figure1.

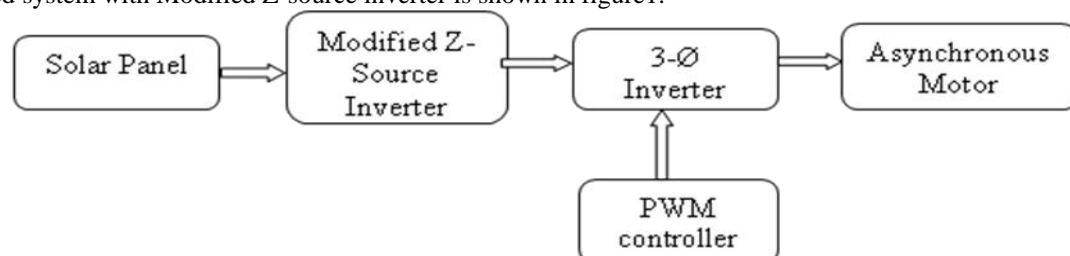

Fig 1. Block diagram of the proposed model

The primary objective of designing the proposed work is harness the solar energy for the agriculture purposes mainly in the irrigation pumping motors. Present day farmers all over the country are facing numerous problems including power bill due to the irrigation pump motors. In order to find a solution for the above said problem, the work has been proposed. In this proposed work the modified impedance source network is used along with the inverter instead of using the inverter alone. To ensure the boosting of the energy to the inverter, the modified impedance source network is connected parallel to the inverter. The primary source for the inverter is solar energy and pulse width modulator (PWM) controller is used to control the three phase inverter. The alternating three phase energy is fed to the asynchronous motor. The output of the inverter and output of the motor are analyzed by using the MATLAB software with total harmonic distortion values.

Solar panel

Photovoltaic cells are produced by semiconductor technology to convert solar light energy into electrical energy in the form of Direct Current .



Fig.2. Solar Cell



Fig.3. Solar panel and Solar array

The solar panel is group of solar cell, whereas the solar array is group of solar panels as shown in Fig.3. The generated DC power can be used directly to a DC load or it can be inverted into Alternating Current (AC) power to supply a AC load or utility grid. The desired output can be obtained from the solar power generation system by parallel or series combination of solar cells.

Asynchronous motor

Generally the electric motors used by the farmers for their irrigation pumps are of asynchronous type of motors. The unbalanced supply voltage to the motors can cause severe thermal stresses and cause burnouts.

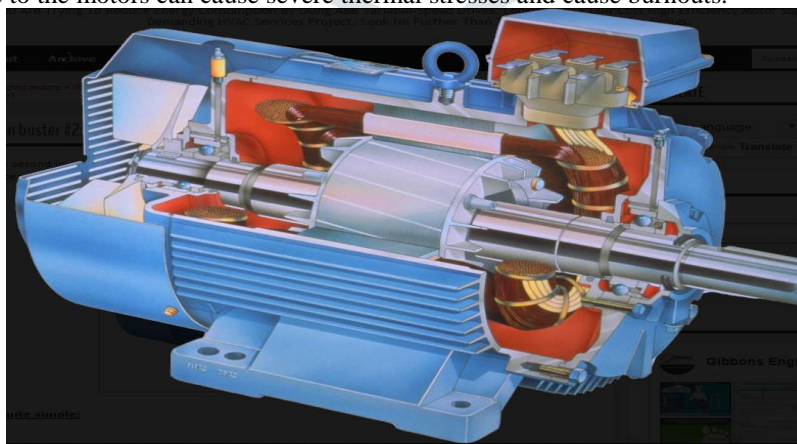

Fig.4. Three phase induction type motor

In this type of working condition asynchronous motor can be a solution for the farmers to avoid financial problems due to burnouts of the motor. Asynchronous motor, in which the electric current in the rotor needed to produce torque is obtained by electromagnetic induction from the magnetic field. It is an attractive solution for high power applications due to its regenerative capability. Hence it is suitable for irrigation pump type of loads.

Inverters & PWM (Pulse Width Modulation) Techniques

An inverter is basically a converter that converts DC to AC power and is 2 types generally. Those are Voltage Source Inverter [VSI] & Current Source Inverter [CSI]. VSI is one, in which the DC input voltage is essentially constant, feedback diodes are necessary and output voltage wave form doesn't depends on type of load. CSI is one, in which the source current is predetermined and the load impedance determines the output voltage. Here the supply current can't change quickly. The current is controlled by series DC supply inductance. Inverter circuits can be very complex so the objective of this method is to present some of the inner working of inverters without getting lost in some of the fine details. These are used in UPS [Un-interruptible Power Supply], industrial drives, traction & HVDC.

PWM techniques are also called as internal techniques. In this, the output of an inverter can be controlled by adjusting turn-on and turn-off times of the switches internal to the circuit. The main objectives of PWM controller are to control RMS value of the output voltage & to eliminate the lower order harmonics to the possible extend. Any PWM method will be considered to be effective, if it can eliminate more number of lower order harmonics. So that, the higher order harmonics can be filtered out with small size of LC filter.

$$\omega = \frac{1}{\sqrt{LC}}$$

If ω increases then both L&C decreases

In PWM inverter circuit, to eliminate nth harmonics the output voltage pulse width should be $\frac{2\pi}{n}$.

PWM techniques can be used to get improved output currents and voltages. It uses switching on and off at speed to regulate the flow of current. The major advantages of PWM techniques are greater efficiency, less heat dissipation needed and higher power output for the same type of regulator component.

Z-source Inverter

The Z-source inverter topology has a unique impedance network front end consisting of two inductors and two capacitors. Compared to a voltage-source inverter that can only operate in 6 actives states and 2 zero states, the Z-source inverter can also operate in the shoot-through states where the upper and lower switches in one or more phase legs are gated on simultaneously. Since shoot-through events no longer result in inverter failures, the Z-source inverter is more robust against EMI and parasitic turn-on of devices.

Proposed work in the simulated model

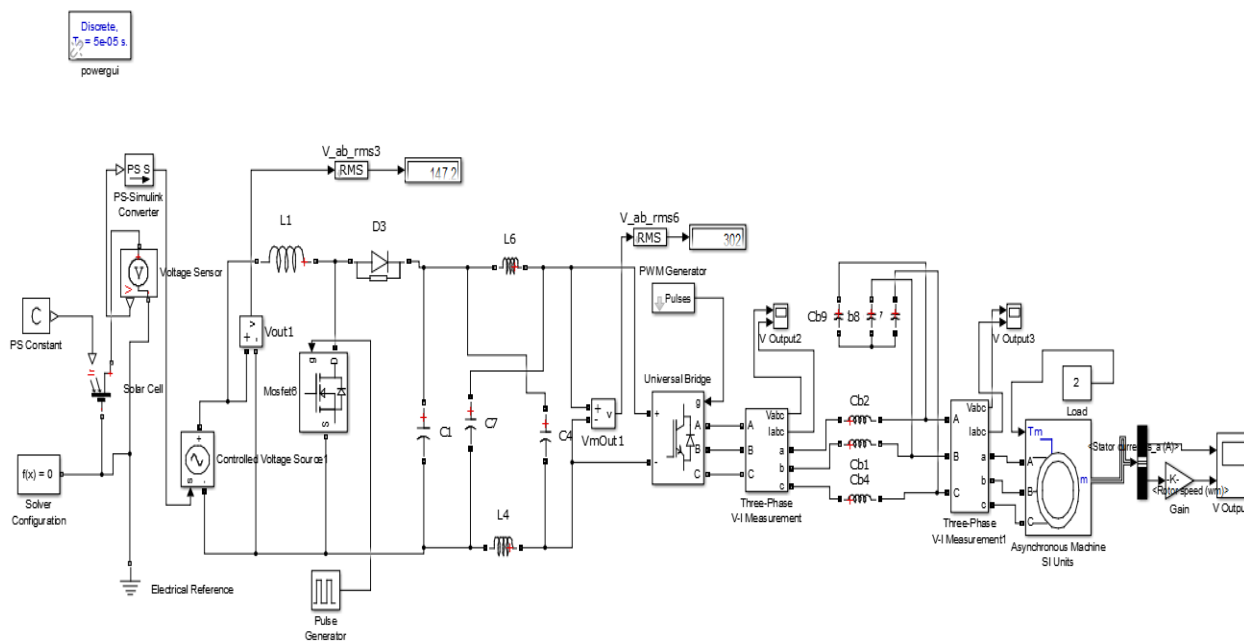

Figure 5. Proposed work in the simulated model.

Results and discussion

The temperature and solar irradiation play a crucial role among the various factors in deciding the PV output voltage and current. These problems are minimized by using modified Z-source inverter. The output of the work with modified Z-source inverter is better than with ordinary Z-source inverter. Generally change in solar irradiation will cause the PV output current to change considerably. The duty cycle D is directly proportional to the environment changes, which inverse a small change in the environment with solar irradiation or temperature will cause a small change in the duty cycle D. The simulated results of the proposed solar power generation using modified Z-source inverter shows that the generated voltage and current is within the criteria of IEEE standard 519-1992 and can be able to feed the asynchronous motor, which is given Fig.7 and Fig.8. As a result speed of the motor is seems to be good after 1.5 seconds, which is shown in the Fig.9.

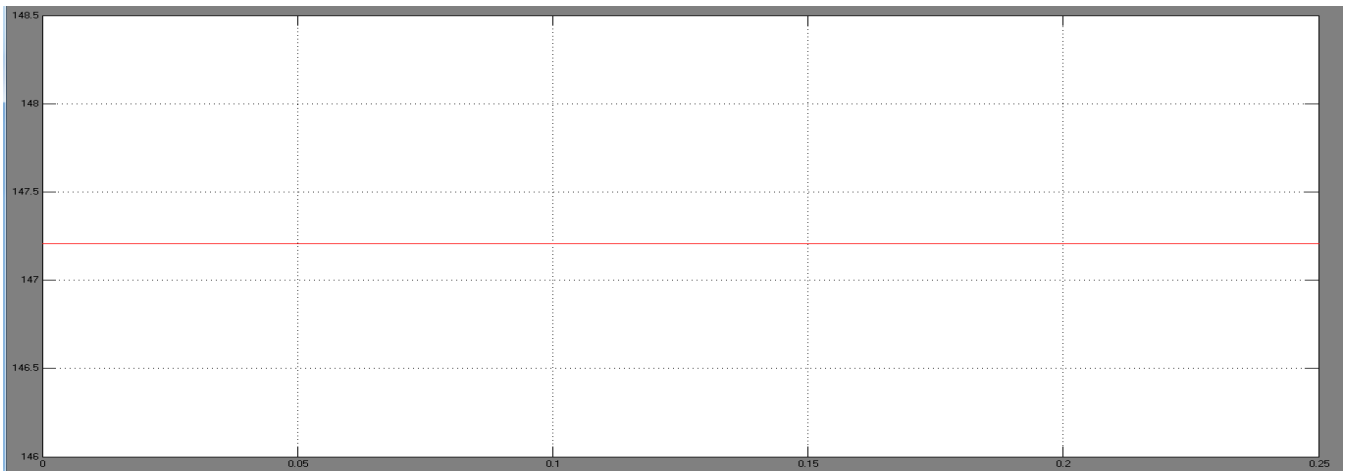

Fig 6.Output voltage of PV module

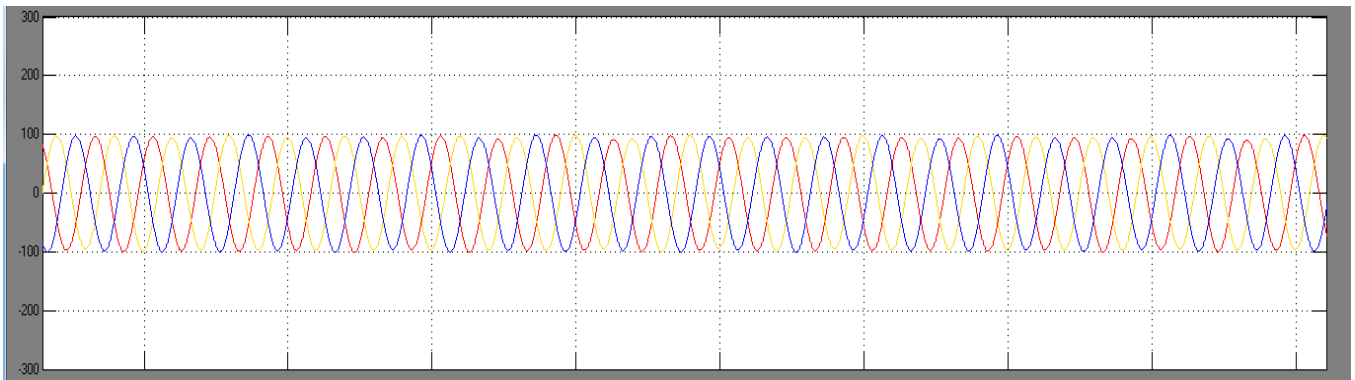

Fig 7.Output voltage of three phase inverter

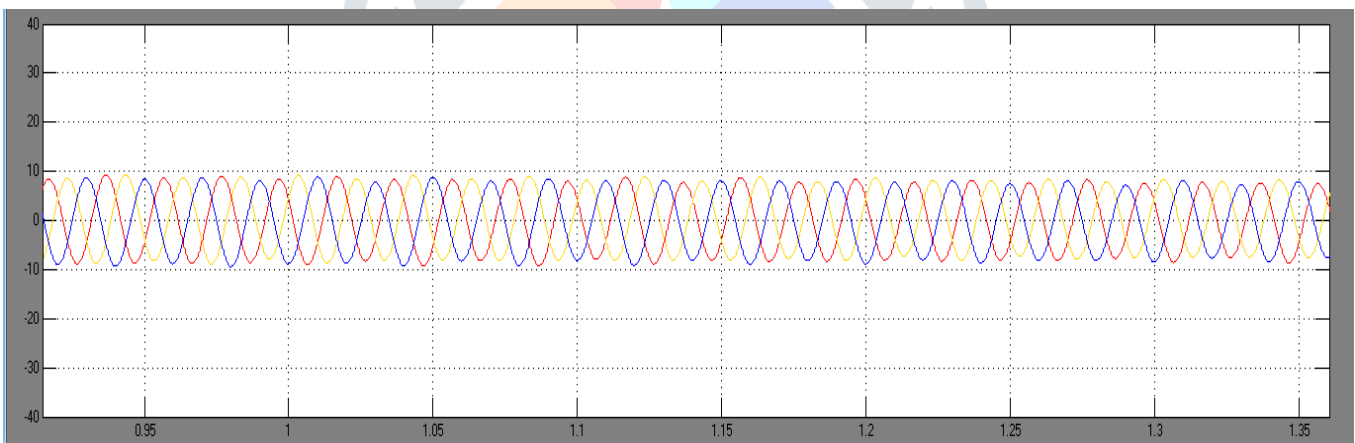

Fig 8.Output current of three phase inverter

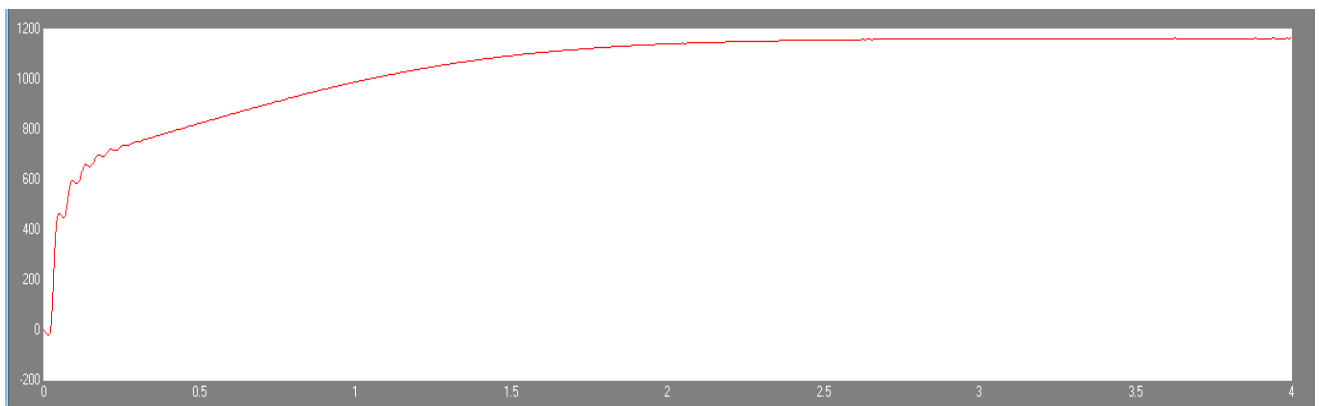

Fig 9.Speed of the three phase asynchronous motor

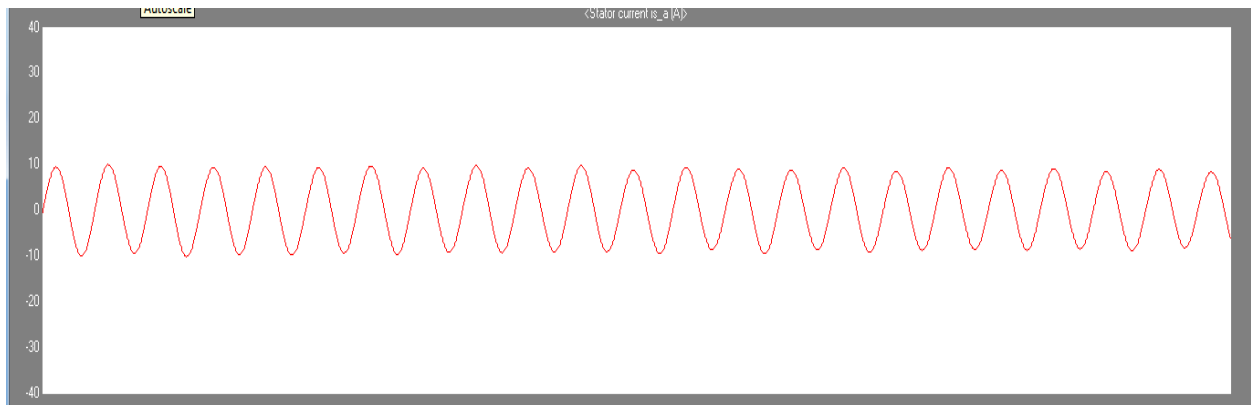

Fig.10.Stator current of the three phase asynchronous motor

Conclusion

The modified Z- source network along with the three phase inverter is showing good results, which can be more companionability for the three asynchronous motor. The proposed Solar Photovoltaic system along with the modified Z- source inverter and PWM technique generates good voltage and current waveforms required for the three phase induction motor. The same work can be extended to the solar electric vehicle also. The proposed Solar Photovoltaic system has given a better performance even under various environmental changes like solar irradiation and temperature. The overall system has been analyzed and performance was studied by Matlab/Simulink results.

References

1. Michael ropp,E.,Sigifredo Gonzalez.(2005).Development of a MATLAB/Simulink Model of a Single-Phase Grid-Connected Photovoltaic System.IEEE Transactions on Energy Conversion.
2. .Hua, C.C., Shen, C.M. (1998). Study of maximum power tracking techniques and control of dc-dc converters for photovoltaic power system. Proceedings of 29th annual IEEE Power Electronics Specialists Conference, vol. 1, pp. 86-93.
3. Sira ramírez, H., Nieto, M. D. D. A., Lagrangian. (1996).Approach to Average Modeling of Pulse width Modulation Controlled DC-to- DC Power Converters. IEEE Transactions on Circuits and Systems-I: Fundamental Theory and Applications, v. 43, p. 427-430, Maio.
4. Arulmozhiyal.R and Baskaran.K “A Novel Approach to Induction Motor speed control using FPGA”, International Journal of Applied Engineering Research, Vol. 4, No.1,Jan 2009, pp. 1-14
5. SIRA-RAMÍREZ, H.; NIETO, M. D. D. A Lagrangian Approach to Average Modeling of Pulsewidth-Modulation Controlled DC-to- DC Power Converters. IEEE Transactions on Circuits and Systems-I:Fundamental Theory and Applications, v. 43, p. 427-430, Maio 1996.