

UNMANNED AUTOMOBILE ANDROID CONTROLLING SYSTEM

NilugondaVyshali¹, Pinninti Sravani², Sriperumbudur Navya³
^{1,2,3}B.Tech-Students Department Of Computer Science And Engineering
 Balaji Institute Of Technology &Science,Narsampet,India

Abstract:

The theme of project is to drive the car with the help of Android application using sensors. The main object of this unmanned car is to handle the dangerous situation. Basically unmanned system works with wireless communication system using radio waves, microwaves and other controlling signals. So, we proposed a novel for control system for unmanned vehicle. In this system android application can handle all controlling signals and it will be transmitted to the vehicle in a WI-FI medium. By this WI-FI medium we can control entire vehicle through internet. By using the Android application we can control the car from anywhere any time with the help of sensors we can detect the pedestrian coming by that we can reduce the speed limit of the vehicle and we may also decrease the road accidents according to the people.

Key words: IOT, MIT APP, NODE MCU, ARDUINO IDE.

1. INTRODUCTION:

Unmanned is software which operates on itself without human involvement. It is an automatic system .It was operated through node MCU, Router, Switches and IOT. It is operated from our PC or mobile. This unmanned system is more useful in this Generation, Now a day this unmanned controlling system plays a vital role in automobile city. The hardware and software systems operate semi and fully autonomous vehicles, the unmanned system used in an autonomous vehicle determine its capabilities and reliability. Especially those possible without human input or correction which is definition autonomy. More advanced unmanned system technology can drive more complex systems with a greater level of autonomy. This unmanned controlling system uses various components in it and it requires a technology. It is running through Android application.

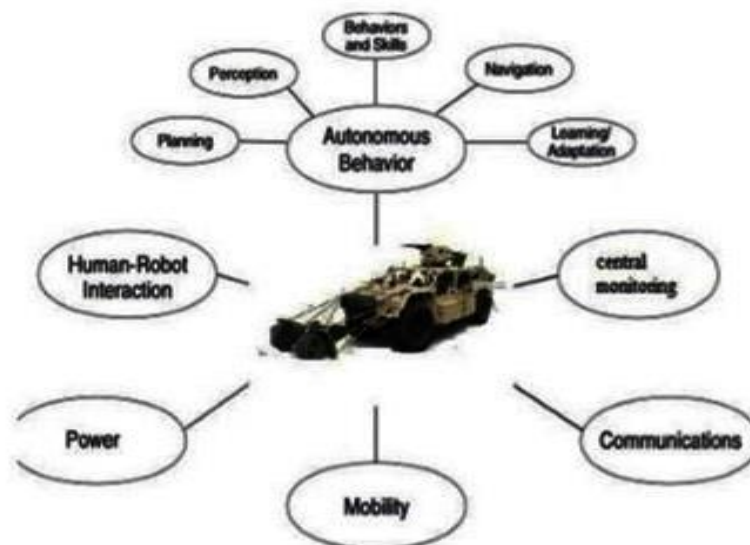

Figure 1: Unmanned System

The type of technology used in unmanned systems includes:

- Sensors
- Machine vision
- Navigation
- Object recognition
- Facial recognition

While the technology can be used for many purposes and types of vehicles, there has been a focus in the development of military drones, also known as unmanned air vehicle(UAV).Along with drones other type of unmanned vehicle systems include unmanned ground vehicles(UGV) and unmanned water vehicles, including both surface and undersea craft.

2. COMPONENTS & ACCESSORIES:

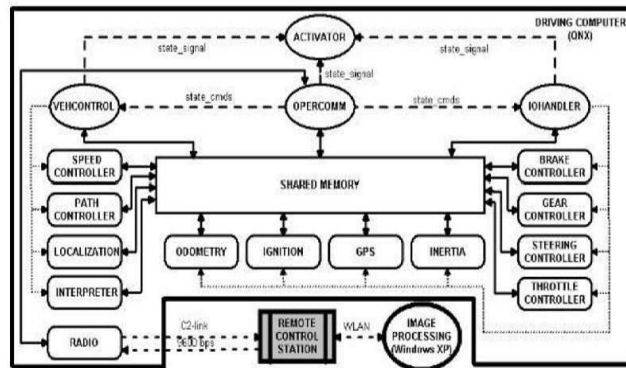

Figure 2: Flow Diagram of Unmanned System

The controller is request for MCU. The controller is responsible for returning or the response for the request. Controller controls all the flow of application from one state to another, it works for execution. The word relays refers to the switching Device. Types of relays depend on the function protective, reclosing, regulating, auxiliary and monitoring relays are some of the categories. Unmanned source is an online supplier of unmanned parts, components, systems and more. We are a single source of supply and information that serves commercial, governmental, public sectors. Built on more than 25 years of industry experience, unmanned systems source is an innovative site. Buyers can shop top-tier products from industry-recognized manufactures as well as find extensive product descriptions, technical data, specifications and drawings.

3. ARDUINO IDE:

Arduino is a platform (open-source) which is easy-to-use the hardware and software. It consists of a circuit board, which can be program (referred to as a microcontroller) with a ready-made software called Arduino IDE (Integrated Development Environment), where it can be used to write and upload the computer code to the physical board.

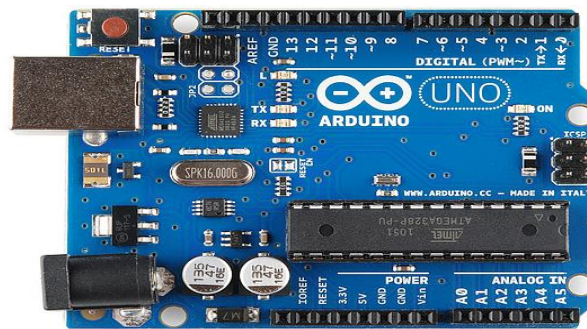

Figure 3: Arduino IDE

The above diagram consisting of different kinds of pins where there will be a USB cable pin which is used to connect arduino with your computer. The current version of arduino is 1.8.8. The range of the voltage in the arduino will be in the range of 3.3v to 5v. It consist of digital pins, analog pins, power pins. It contains 3 GND(ground) pins any of which is connected to ground your circuit, 0 to 7 are the digital input pins and 8 to 13 are digital output pins. VIN input pin is used to connect or supply the voltage to the other board. Power pins are used to generate lower output, reset pin used to reset the sensors. The basic programming of arduino consist of two functions i.e. loop () and setup (). The setup function is used to initialize the variables, pins and board components whereas, loop () is used for logical coding.

4. DESIGN MODEL OF NODE MCU:



Figure 5: Node MCU

Node MCU uses lua scripting language. MCU stands for Microcontroller Unit. It is a computer on a single chip and it has built-in support for Wi-Fi connectivity. The node MCU is a micro controller unit it is an environment that built both hardware and software in an open source. It includes permanent software programmed into a read only memory, which runs on the ESP- 232. Node MCU was created shortly after ESP8266 came out, on December 30, 2013. Expressif systems began production of the ESP8266 it is a Wifi source integrated with a TensilicaXtensa LX106 core, widely used in IOT applications .Node MCU started on 13 Oct 2014.

PIN DIAGRAM:

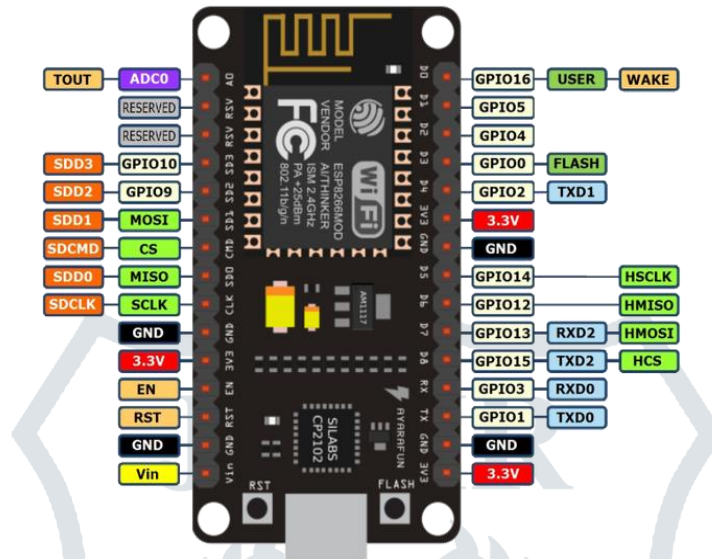

Figure 6: Pin Diagram of Node MCU

4. APPLICATIONS:

Unmanned controlling system is used in military purpose, navigation purpose and forestry purpose. The sensors used in unmanned controlling system will detect the pedestrians coming. So, by that we reduce the speed limit. There are many limitations of unmanned system. The PC working may stop suddenly. GPS may fall due to sudden weather changes, the battery used in the PC may not work when it is necessary, moreover this unmanned vehicles is more expansive than the normal vehicles. Due to this unmanned vehicle the drivers will be unemployed which is a big loss to them and they should learn new technology to drive this vehicle which is more complicated to them. If we are using this vehicle through our mobile, then the battery may loss sometimes and by this we can't drive it when it is necessary.

5. DESIGN VIEW OF ANDROID MODULE:



Figure 7: Android Application

Through android application we can operates unmanned controlling System. In android application it contains node MCU. Which contains ESP 232 and four switches like break, clutch, gear, and accelerator? Which is connected to router and this router is connected to our mobile which contains android application (MIT app inventor) and it also contains 4 switches. By operating this switch from our mobile, it sends the signals to node MCU according through the switches pressed.

CONCLUSION:

In future, it was more scope. This unmanned system will reduce the accidents and control the death rates. Due to the sensors used we detect the pedestrians coming and reduce the speed limit, used for military purpose, forest purpose. IOT and android application vehicle is controlled. In future this unmanned system will be accessed by global communication system that can be extended by new research in automobile communication system through internet of things.

REFERENCES:

- [1]. Ahamed, B. B., & Hariharan, S. (2012). Implementation of Network Level Security Process through Stepping Stones by Watermarking Methodology. International Journal of Future Generation Communication and Networking, 5(4), 123-130.
- [2] Ahamed, B. B., & Hariharan, S. (2012, December). State of the art process in query processing ranking system. In 2012 Fourth International Conference on Advanced Computing (ICoAC) (pp. 1-5). IEEE
- [3]. Malathi, N., and M.Sivaram. "An Enhanced Scheme to Pinpoint Malicious Behavior of Nodes InManet's." (2015)..
- [4]. D. Manojkumar, P. Mathankumar, E.Saranya,S.Pavithradevi, "Mobile controlled robot using DTMFtechnology forIndustrialapplication",InternationalJournal of Electronic Engineering Research]
- [5] Mahalakshmi,K., Sivaram, M., & Yuvaraj, D.(2018). Healthcare Visible Light Communication. International Journal of Pure and Applied Mathematics, Volume 118 No.11 ,PP 345-348.
- [6] .J.Suthakorn, S.S.H. Shah, S. Jantarajit, W.Onprasert,W. Saensupo, S. Saeung, S. Nakdhamabhorn, V. Sa- Ing, S.Reaugamornrat, "On the Design and Development of A Rough Terrain Robot for Rescue Missions",proceedings of the 2008 IEEE International Conference on Robotics and Biomimetics, Feb 21– 26,2009.
- [7] .David P. Miller, Rajiv S. Desai, Erann Gat, Robert Ivlev,John Loch,Reactive Navigation through Rough Terrain, July 1992.

BIOGRAPHY:**Nilugonda Vyshali**

Pursuing B.Tech in Computer Science and engineering Balaji Institute of Technology Sciences, Narsampet, Warangal, INDIA.

**Pinninti Sravani**

Pursuing B.Tech in Computer Science and engineering at Balaji Institute of Technology Sciences, Narsampet, Warangal, INDIA.

**Sriperumbudur Navya**

Pursuing B.Tech in Computer Science and engineering at Balaji Institute of Technology Sciences, Narsampet , Warangal, INDIA