

# Performance Analysis of DFIG Wind Turbine System using FACTS Devices

Uday Kumar  
Assistant Professor  
Geetanjali Institute of Technical Studies  
Udaipur, INDIA  
[udaykumar.mittal@gmail.com](mailto:udaykumar.mittal@gmail.com)

Bherudas Vairagi  
Assistant professor,  
Geetanjali Institute of Technical Studies, Udaipur  
GITS, Dabok, Udaipur.  
Udaipur, INDIA

In recent years the Doubly-Fed Induction Generator (DFIG) based wind turbine system has gained a lot of popularity due to its various advantages, but it has certain demerits also. The sudden tripping of these generators because of the low voltage during fault conditions, results in poor grid stability. One of the most reliable solutions to this problem is the use of Flexible AC Transmission System (FACTS) devices. They ensure the uninterrupted operation of DFIG system and thus maintain the stability of the system. This paper presents the application of UPFC (Unified Power Flow Controller) and HPFC (Hybrid Power Flow Controller) in the DFIG based wind turbine system in order to provide the dynamic reactive power support at the point of common coupling amid three-phase fault condition. A comparison between the performances of the two devices has also been discussed. The simulation has been done in MATLAB/Simulink platform.

Keywords:

*Keywords- Wind Energy Conversion System, Doubly-Fed Induction Generator, FACTS Devices, Unified Power Flow Controller, Hybrid Power Flow Controller*

## I. INTRODUCTION

With the advancement in power electronics the idea of a Variable-Speed Wind Turbine (VSWT) fitted with a Doubly-Fed Induction Generator (DFIG) has gained a lot of interest due to its various benefits over other wind turbine generators. DFIG can work at a wide range of speed contingent upon the wind speed or other particular operation necessities. Earlier the wind turbine system was allowed to be disconnected from the grid amid fault conditions so as to avoid any possible damages to wind turbines. But nowadays, Flexible AC Transmission System (FACTS) devices like Unified Power Flow Controller (UPFC) and Hybrid Power Flow Controller (HPFC) with excellent dynamic responses are technically and economically feasible in resolving such issues. They assure stable operation of wind turbine generators and also sustainable power delivery to the grid during abnormal operating situations.

The use of Static Synchronous Compensator (STATCOM) to obtain continuous operation of wind turbine equipped with DFIG amid grid faults and to maintain its stable operation is very prominent and investigated by many researchers [2], [4] and [5]. This paper presents the application of UPFC and HPFC to improve the performance of DFIG system under three-phase fault condition. Also the comparative study of both the devices will guide in selecting the optimum FACTS device that meet both cost and performance requirements for specific fault condition.

## II. PROBLEM AREAS

With the rapid increment in penetration of wind power in power system, tripping of many wind turbines in a substantial wind farm amid grid abnormalities may start to influence the overall power system stability. During fault due to excessive over current in the rotor circuit of DFIG causes the protective system to disconnect the DFIG system in order to avoid any possible damages to the system. Thus, the most essential issue for wind farm is the Fault Ride-Through (FRT) capability and stability of the system.

## III. DFIG BASED WIND TURBINE SYSTEM

The stator of DFIG is directly connected to the grid while the rotor is connected to the utility grid by means of a partially rated variable frequency ac/dc/ac converter, which just needs to deal with a fraction (25%–30%) of the total DFIG power to acquire full control of the generator. By the help of these converters the magnitude and phase of the rotor voltage can be controlled, so as to make active and reactive power control possible.

The purpose of the Grid Side Converter (GSC) is to keep the DC link voltage constant. The GSC acts as auxiliary reactive power compensation however the reactive power capability of this converter during the fault is limited as it is rated around 25% of the wind turbine power rating. The main purpose of the Rotor Side Converter (RSC) is to maintain the rotor speed constant regardless of the wind speed. RSC also controls the stator active and reactive power flow of the machine using the rotor current components. The controlling of voltage and reactive power at the grid terminal is done by controlling the reactive power produced or consumed by the RSC.

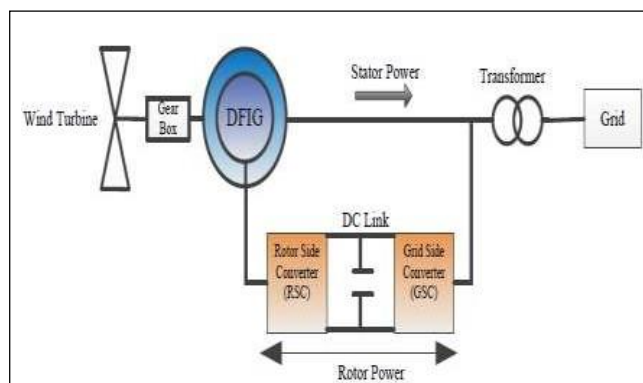

Fig. 1: DFIG based Wind Turbine System

IV. FACTS DEVICES

A. UPFC

The UPFC is a combination of a STATCOM and SSSC (Static Synchronous Series Compensator) coupled by means of a common DC voltage link. The shunt and series converters of the UPFC can control both active and reactive power of the system at the point of common coupling (PCC) smoothly, rapidly and independently in four quadrant operation.

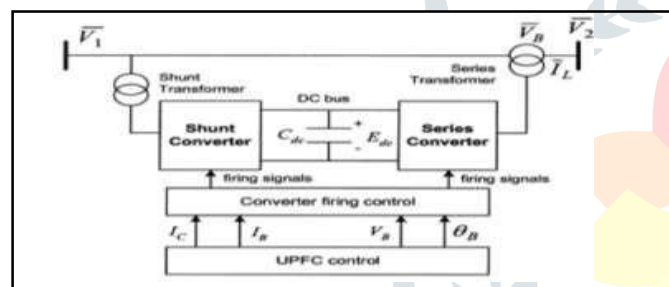
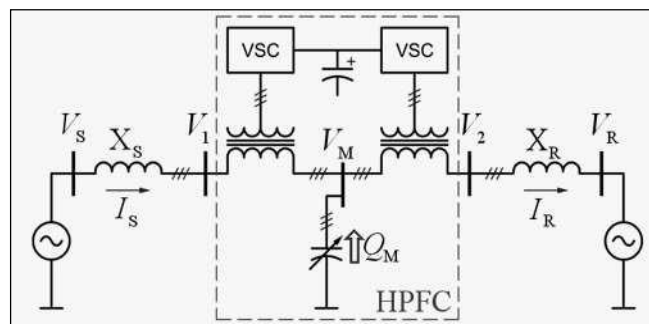

Fig. 2: Unified Power Flow Controller

B. HPFC

The HPFC is a combination of Static Var Compensator (SVC) which is a shunt connected controllable source of reactive power and two series connected voltage source converters, i.e. SSSC, on each side of the shunt device. A common dc link has been provided to exchange active power. The flow of active and reactive power through the transmission line can be independently controlled by the converters.

Fig. 3: Hybrid Power Flow Controller



V. SIMULATION MODEL

To assess the execution of DFIG based wind turbine system the Standard IEEE 9-Bus power system is considered and simulations have been performed in MATLAB/Simulink platform. The DFIG based wind turbine system is connected at bus 9 of the system and its behavior is studied under three-phase fault with and without UPFC and HPFC.

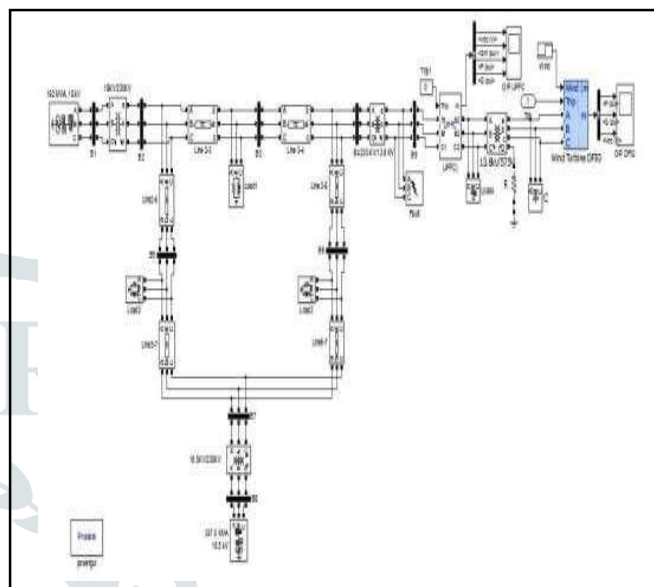

Fig. 4: Simulation Model of Test System

Fig.3 represents the simulation model of the test system. During the fault period the voltage dips at the connection point which in turn induces over current in the circuit and hence can damage the converter or trip the DFIG system from 9-Bus power system. Therefore to maintain stability and uninterrupted operation of DFIG system, UPFC is connected in series with the faulted system at bus 9. The UPFC provides the required dynamic reactive power support to DFIG system and ensures its stable operation. Similarly to analyze the effect of HPFC on the DFIG based wind turbine system under faulted conditions, the UPFC in the above figure is replaced by HPFC.

VI. RESULTS AND DISCUSSIONS

*Without FACTS Devices:* A short duration three-phase fault occur at Bus-9 of the power system at t=0.020s. During the fault period the DFIG wind turbine system remains disconnected from the power system as its protective system is designed to trip the wind turbine when the voltage at PCC drops to 75%. Consequently, the active power of DFIG is reduced to zero. Also the DFIG will not be able to exchange reactive power with the system as shown in waveforms as well. There is a sharp overshoot in the dc-link voltage during the fault due to high over current in the RSC as shown in the third waveform.

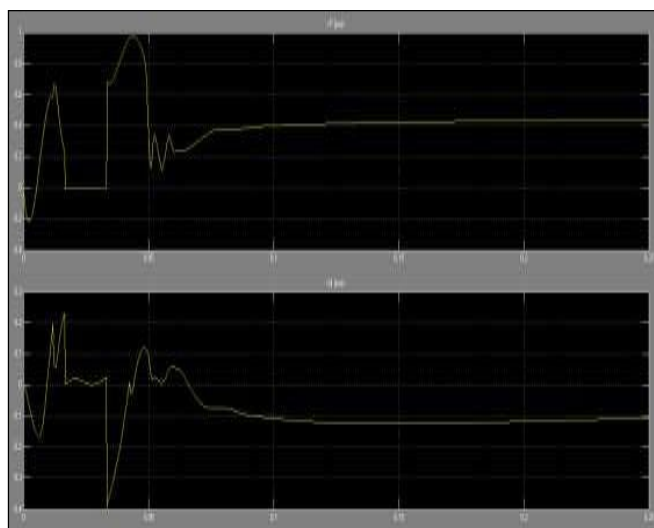

Fig. 5(a): Active and Reactive power of DFIG based Wind Turbine System under L-L-L fault

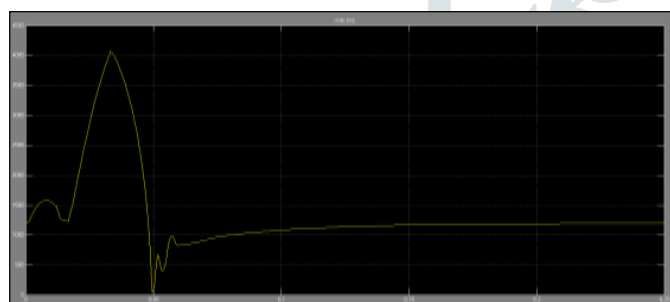
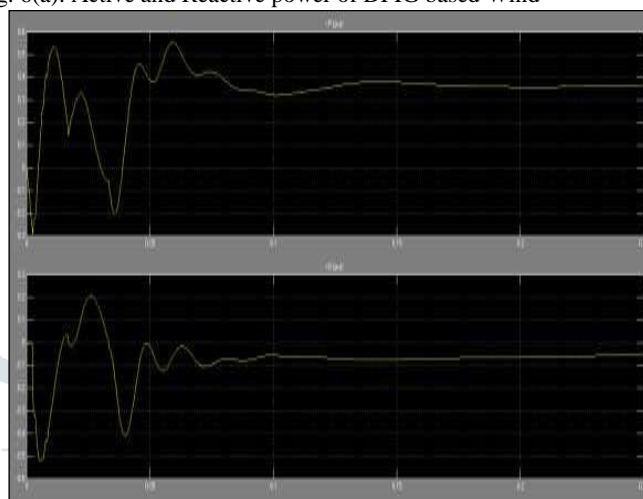

Fig. 5(b): DC-Link Voltage of DFIG based Wind Turbine System under L-L-L fault

Fig. 6(a): Active and Reactive power of DFIG based Wind



Turbine System under L-L-L fault with UPFC

Fig. 6(b): DC-Link Voltage of DFIG based Wind Turbine

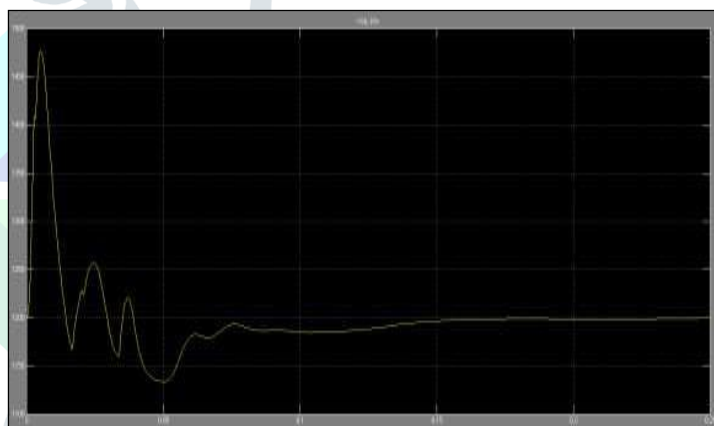

System under L-L-L fault with UPFC

**B. With FACTS Devices**

**(i). UPFC:**

After installing a UPFC at Bus 9, it provides the required reactive power so as to maintain the desired voltage at PCC and thereby maintaining the DFIG based wind turbine system in service during and after the fault. DFIG consumes reactive power during fault as shown by the waveform and after fault clearance it delivers reactive power to the system aiding in restoring system stability. The peak overshoot of dc-link voltage also gets reduced by incorporating UPFC as shown by the third waveform below which implies less over current in rotor circuit and hence safe operation.

**(ii) HPFC**

During fault, the two series converters of HPFC inject the required voltage in series with line while the shunt converter i.e. SVC provides the demanded reactive power in order to maintain DFIG system in service during fault. As shown by the waveforms of active and reactive power, by incorporating HPFC the oscillations in the system gets reduced and also the system restores quickly after fault clearance i.e. at  $t=0.06s$  in this case. Also the magnitude of peak overshoot of DC-link voltage is less while using HPFC as contrasted to UPFC.

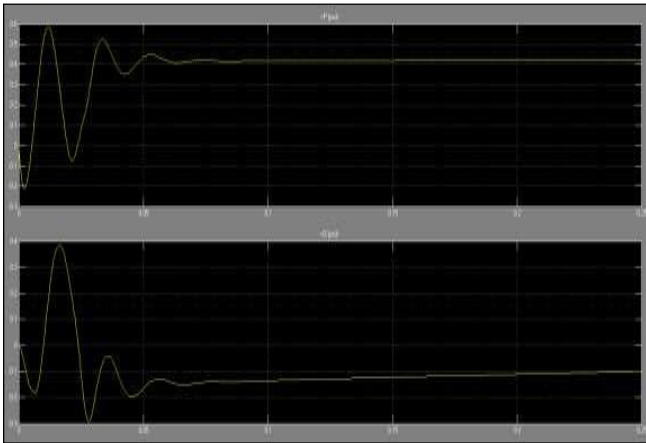

Fig. 7(a): Active and Reactive power of DFIG Wind Turbine System under L-L-L fault with HPFC

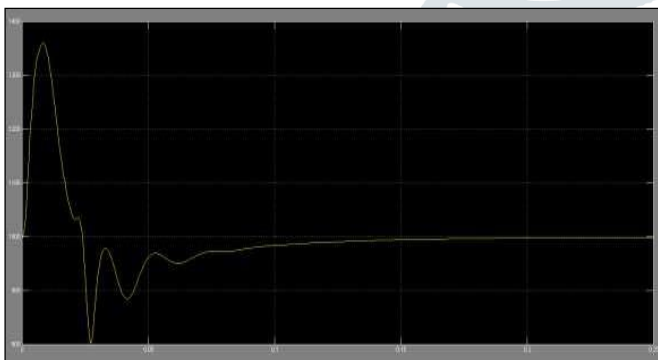

Fig. 7(b): DC-Link Voltage of DFIG Wind Turbine System under L-L-L fault with HPFC

By analyzing the results it can be concluded that the system restored its stable operation in less time while using HPFC rather than UPFC. Also the peak overshoot of DC-link voltage is reduced in case of HPFC which implies reduced over current in the rotor circuit and thereby less losses and protection against damages to the converter circuit.

## VII. CONCLUSION

A comparative study of the implementation of both UPFC and HPFC on the DFIG based wind turbine system shows that HPFC gave better performance over UPFC regarding dynamic power compensation. It is also concluded that as UPFC is a combination of two converters while HPFC is a combination of one passive component and two converters of half MVA ratings, hence a sufficient amount of cost can be reduced by savings in the total required converter MVA ratings. Thus the traditional FACTS controllers can be utilized by making their hybrid combinations rather than replacing them completely.

## REFERENCES

- [1] YAO Xing-Jia, LIU Shu, WANG Xiao-Dong, GUO Chang-Chun, XING Zuo-Xia and JIANG Hong-Liang, "Doubly-Fed Induction Generator Control for Variable-Speed Wind Power Generation System," IEEE International Conference on Mechatronics and Automation August 9 - 12, Changchun, China 2009.
- [2] Mehrdad Fazli, Ali Reza Shafighi and H. A. Shayanfar, "Effects of STATCOM on Wind Turbines equipped with DFIG during grid faults," IEEE World Non Grid Connected Wind Power and Energy Conference 2010.
- [3] Satish Choudhury, Kanungo Barada Mohanty and Birendra Kumar Debta, "Investigation on Performance of Doubly-Fed Induction Generator Driven by wind turbine under Grid Voltage Fluctuation," 10<sup>th</sup> International Conference on Environment and Electrical Engineering 2011.
- [4] Swagat Pati, D. B. Mohanty, S.K. Kar and Smruti Soumya Dash, "Performance Improvement of a DFIG based Wind Energy Conversion System during Low Voltage Conditions using STATCOM," IEEE 9<sup>th</sup> International Conference on Industrial and Information Systems 2014.
- [5] Anzum, Dr. Shankar C.B. and Dr. R. Prakash, "Stability Enhancement of DFIG Based Wind Farm Connected to a Grid Using STATCOM," Annual IEEE India Conference (INDICON 2015).
- [6] Yasser M. Alharbi and A. Abu-Siada, "Application of UPFC to Improve the Low-Voltage-Ride-Through Capability of DFIG," IEEE 24<sup>th</sup> International Symposium on Industrial Electronics (ISIE 2015).
- [7] Lini Mathew and S. Chatterji, "Modeling and Simulation of Hybrid Power Flow Controller Implemented on Multi-Machine System," 2015 RAECs DIET Punjab University Chandigarh 21-22nd December 2015.
- [8] A. F. Abdou, Yasser M. Alharbi and A. Abu Siada, "Application of UPFC on Stabilizing Torsional Oscillations and Improving Transient Stability," Australasian Universities Power Engineering Conference, AUPEC 2013, Hobart, T AS, Australia, 29 September - 3 October 2013.

