

Fabrication of Low Cost CNC Router for Drilling

Shirish Sonawane¹, Sayali Landge², Asha Dhapate³, Sapat Bansode⁴

Department of Mechanical Engineering, Savitribai Phule Pune University, Pune, Maharashtra

Abstract –The CNC machine are there from many years, but mostly they are unreachable to vast community specially students. Another disadvantages with them is that they are bulky and expensive. Why we can't make a CNC like printer? Why we can't make a CNC for small jobs with low capacity? There is lack of low cost CNC in market which can teach and also work. In this paper we are showing that how you can build up CNC using mechanical as well as electrical components. What are the basic requirement for building a CNC and how to control them?

Key Words: CNC, ARDIUNO, MOTORS, LEAD SCREW

1. INTRODUCTION

CNC machining is a process used in the manufacturing sector that involves the use of computers to control the machine tools. Tool that can be controlled in manner like lathes, mills, machine and grinders. The CNC stands for Computer numerical control.

We are presenting here an idea of CNC spindle drill. The idea behind this project is to make a small CNC machine which can draw image or picture on surface which can be a paper or anything. This machine is also used in the making manufacturing part purpose. There are many type of CNC machine. The common type of CNC machines are two-axis and three-axis CNC machine. The two-axis machine can move on vertical and horizontal only which are X axis and Y axis. Three-axis machine can do movement starting with three primary axis which are X, Y, Z axis. The Z axis is being parallel with the spindle. The CNC machine operation starts with the collecting the data from the programming that extract from the computer-aided design.

This paper discusses the design and realization of complex 3-axis CNC machine based on microcontroller which combined with spindle drill. The program produce the computer file and then will extract the command to operate the machine. The program will be transfer via post-processor and then be loaded into the CNC machine to start the machining.

2. LITERATURE REVIEW

Detailed survey on the research works recently published in the eminent journals was studied in-depth to acquire best knowledge and understand the constraints of the study.

R. Ginting, S. Hadiyoso (2017) published "Implementation 3-Axis CNC Router for Small Scale Industry" in this research paper he discusses the design and completeness of complex 3-axis CNC machine based on microcontroller which combined with spindle drill. The first step in the operation of CNC machine was design picture that have been made on the PC send to microcontroller using serial communication then cnc perform execution on object according to point coordinates. Working with automatic mechanical equipment demands precise, Infallibility, velocity, consistency and flexibility. The CNC machine can be used for mechanical work such as cutting, engraving and marking on wood to form 2D or 3D objects with 98.5% carving accuracy and 100% depth accuracy.

Kajal J. Madekar and Kranti R. Nanaware (Feb-2016) both deals with the design of automatic mini CNC machine for PCB drawing and drilling in the research paper of Automatic mini CNC machine for PCB drawing and drilling in this research paper. The Idea behind is to design and drill PCB based on low cost CNC system the lower cost is achieved by incorporating features of PC with ATMEGA 328 controller in an Arduino. We have use an G code for whole system operation G code is nothing but a language in which people tell computerized machine tools 'How to make something'.

Vikas S. Mane (2017) discusses other fundamental concept, CNC machining is an operation use in the industrial manufacturing field that involve the use of computers to control machine tools. Vikas S. Mane also research a inspiring from this rapid growth of CNC technology and revolutionary change in the world of digital electronics and microcontroller he presenting idea of CNC pen plotter using built PLC. A small CNC machine we can draw image and any object we want which can be a paper or stool and any other tool. Which can be use as the manufacturing of object.

Awari studied other fundamental research, deal a study for selecting parts and material for low cost CNC milling machines that can be used in a small scale industry. Therefore in this paper is discussed a design of cheap 3-axis router CNC machine based a microcontroller as it is its main controller.

Linyan Liu et al. (2014) represent knowledge-centric process management framework machine tool design and development with the integration of process. After review of above paper we can say that, CNC router must be better design and construct and must be more accurate than conventional machine.

3. OBJECTIVE

The objectives of this study are:

- To develop a low cost automatic mini CNC machine for PCB drawing and drilling.
- The main purpose of this work is to make efficient, reduce errors and increase the flexibility.
- To work in more than 2axis.
- Increase the accuracy of the productions.
- The vibration and noise, as well as pollution to the environment, are markedly reduced.
- As the machine becomes denser and lighter, it becomes more portable.
- The layout of the manufacturing plant can be more flexible.
- The productivity and manufacturing speed also increases due to possible faster operation.

4. MECHANICAL DESIGN:

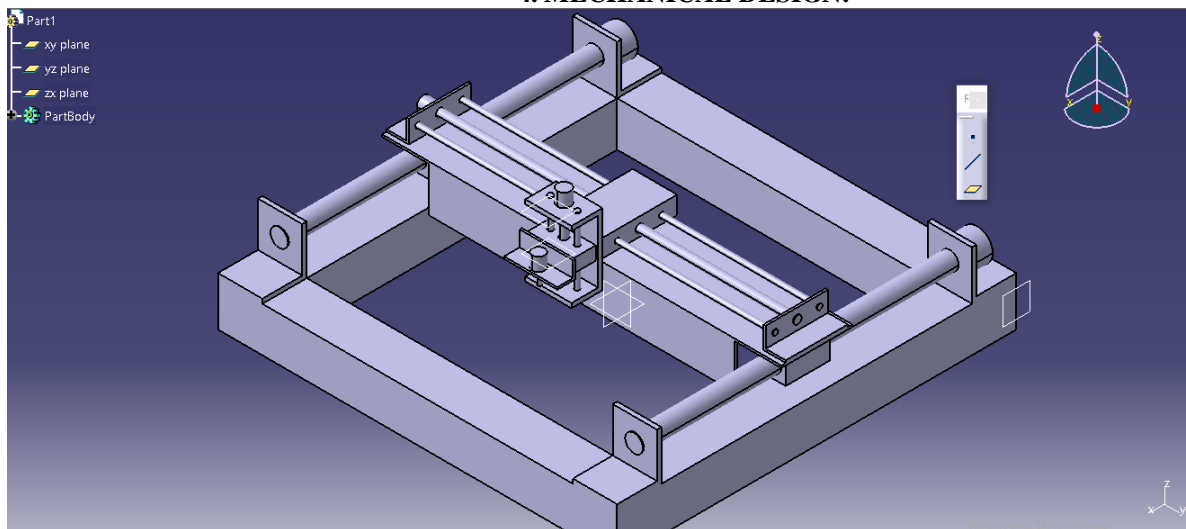

4. COMPONENT SELECTION

Following are component are used in a construction of the CNC router they are as follow:-

4.1 Frame:-

The structure which support the whole machine is called frame. It can be made of various material like wood aluminium. Generally box like structure are preferred and they made using above materials.

4.2 Roller bearing:

A Ball bearing is a type of rolling element bearing that uses balls to maintain the separation between the bearing races. The purpose of a ball bearing is to reduce rotational friction and support radial and axial loads.

4.3 Lead screw

Lead screws are quiet, smooth, resistant to corrosion, self-lubricating, and often less expensive. They are favoured in situations that require higher levels of customization. When selecting the lead screw, we want to have the smallest pitch size possible to increase our resolution. The current market has various models and quality levels to choose from.

4.4 Drill Tool

Drill is a cutting tool comprised of cutting point at tip of a shaft with helical cutting angle. Drill bit are cutting tool use to remove material to create holes, almost always of circular cross section. Drill bit come in many sizes and shapes and can create different kind of holes in many different materials. In order to create holes drill bits are usually attach to a drill which powers them to cut through the workpiece typically by rotation. The drill will grasp the upper end of a bit called the shank in the chuck.

Types of drill bits-twist drill point drill, bradpoint, fishtailpoint, and taper point.

Electrical components

4.1 Controller

The controller is used for converting the G-code machine language. The most widely used and low cost controller is Arduino. It is a microcontroller based board which have wide application and can be programmed for multipurpose use. It can drive servo and stepper motor along with DC motor. For controlling 3 stepper motor Arduino UNO will sufficient. But for 3D printing machine were more. Controlling power is required Arduino Mega 2560 board is used. The GRBL controller which converts the G code in to machine language is flashed on microcontroller (ATmega328 in case of UNO and ATmega2560 in case of Mega 2560) of the board

4.2 Motor Driver

The Arduino board are operating on 5V and motor are operating on high voltage ranging from 12 V to 36 V. So there is need of driver which can take command from controller and drive the motor. There are many motor driver IC are available in market (i.e. L293D, DRV8825, DRV8824 and DR)

4.3 Stepper Motor:

In most of the CNC stepper motors are used as it is good combination of accuracy and cost. A stepper motor is a brushless, synchronous electrical motor that converts digital pulses into mechanical shaft rotation in a number of equal step. Stepper motor are running in steps usually of 1.8deg to 3.6deg. The signals from the amplifiers are given to the stepper motors to produce movements in the X-, Y-, and Z-directions. An AC/DC motor is used to drive the spindle.

4.4 DC motor

The DC motor is the device which converts the direct current into the mechanical work. it works on the principle of Lorentz law, which states that the current carrying conductor placed in a magnetic and electrical field experiences a force and that force is called as Lorentz force. The Flemming left hand rule gives the direction of the force. The DC motor is used for drilling purpose.

5. FUTURE SCOPE

- The machine can be replaced by a laser to make it work like a laser engraving or cutting machine. Engraving machine can be used on wood.
- The pen can also be replaced with a powerful drill so that it can be used for both milling and drilling purposes.
- The servo can be replaced with a stepper motor and the pen with a 3-D pen to make it a 3-D printer which can print objects with dimensions. By extrapolation of the axes, the working area of the machine can be extended keeping the algorithm unaltered.

6. CONCLUSIONS

With the increasing demand for small scale high precision part in various industries, the market for small scale machine tools has grown substantially. Using small machine tools to fabricate small scale parts can provide both flexibility and efficiency in manufacturing approaches and reduce capital cost, which is beneficial for small business owner. That why we design a small scale three axis CNC machine.

7. REFERENCES

- [1] Rajendra Rajput, Dr. Ajay Kumar Sarathe, Comparative Study of CNC Controllers used in CNC Milling Machine, American Journal of Engineering Research (AJER), Volume-5, Issue-4, pp-54-62
- [2] Akshay R Sonawane, Arun Bhivane, D. S. S. Sudhakar, Development of A3-Axis CNC milling machine with an open source controller, IJRET: International Journal of Research in Engineering and Technology
- [3] Pratik Bhambhatt, Mr. Piyush Surani, Mr. Dhaval P Patel, Amarish Kumar J. Patel, Sunilkumar N. Chaudhari,
- [4] M. Bhavani, V. Jerome, P. Lenin Raja, B. Vignesh, D. Vignesh, Design and Implementation of CNC Router, International Journal of Innovative Research in Science, Engineering and Technology, Vol. 6, Issue 3, March 2017
- [5] Dr. B. Jayachandrababu, O. Vamsi Krishna, P. Abdullah Khan, R. Ananda Reddy, Fabrication of Low Cost 3-Axis Cnc Router, International Journal of Engineering Science Invention, Volume 3 Issue 6 | June 2014 | PP.01-10
- [6] Harsh B. Panchal, Mayur S. VAJA, Priyanka D. Patel, Uday N. Padia, ARDUINO BASED CNC MACHINE, International Journal of Research In Science & Engineering e-ISSN, Special Issue 7-ICEMTE March 2017.
- [7] Dhaval B. Patel, Aniruddh R. Kyada., DIY CNC: A REVIEW, 5th International & 26th All India Manufacturing Technology, Design and Research Conference (AIMTDR 2014)
- [8] R. Ginting, S. Hadiyoso and S. Aulia, Implementation 3-Axis CNC Router for Small Scale Industry, International Journal of Applied Engineering Research ISSN 0973-4562 Volume 12, Number 17 (2017) pp. 6553-6558