

Review on CLD and EHD Image Matching To Improve the Leveraging Data Duplication Performance

¹Pooja N. Umekar, ²Swati C. Pakhale, ³Sapna R. Tayde

¹Assistant Professor ²Assistant Professor, ³Assistant Professor
^{1,2,3} Computer Science Engineering Department
^{1,2,3} Sanmati Engineering College, Washim, India

Abstract : With the wild development in information volume, the I/O bottleneck has turned into an all the more overwhelming test for enormous information investigation in the Cloud. In real paper, propose, an execution arranged reduplication to improve the execution of essential stockpiling frameworks in the Cloud by utilizing information reduplication on the I/O way to expel pointless compose demands while likewise sparing extra room. This exploration works means to kill information duplication in the cloud. Improve the execution of capacity framework. We use idea of picture handling to coordinate the space. In this paper we clarified about the plan and usage of information duplication to improve the effectiveness of capacity in cloud. This framework, actualizes remote information way to deal with servers. A distinctive strategy for us is expel the information duplication away framework by utilizing electronic application in which we can utilize two coordinating specialized CLD(color format descriptor) and EHD(enhance histogram descriptor). Client can peruse picture and transfer the picture on website page then we apply CLD and EHD procedure and after that see transferred picture is now store on cloud or not, on the off chance that there is coordinating picture like transferred picture, at that point we remove referenced of as of now store picture at that point send to the recipient and collector can get the picture. In the event that there is no coordinating picture, at that point transfer new picture to database. By extricating reference of as of now store picture there is no compelling reason to transfer again same picture to database along these lines, we can evacuate information duplication, improve the extra room productivity and exploit organize transmission capacity in this way, our framework more powerful than the information duplication to improve the execution of essential stockpiling framework.

Keywords: Java JDK 6.0, Eclipse, Apache tomcat server, MY-SQL Database.

I. INTRODUCTION

Information duplication frequently called astute crushing or individual case stockpiling. It is forms that annihilates superfluous duplicates of information and chop down capacity overhead.

Information deduplication strategy energize that just a single phenomenal occasion of information is gotten on capacity media, for example, 1) circle 2) glimmer or tape. Information deduplication has been made plans to be a proficient method in Cloud reinforcement and documenting applications to decrease the reinforcement window, advance the extra room capacity and system data transfer capacity utilization. Ongoing examinations uncover that moderate to high information excess unmistakably exists in virtual machine (VM)enterprise [3],[4],[5],[6],[7] and superior figuring (HPC) stockpiling frameworks [8]. CLD and EHD procedures, execution situated deduplication game plan, to improve the execution of capacity frameworks in the Cloud by utilizing information deduplication demands while likewise sparing extra room. In this paper we talked about the plan and usage of information duplication to improve the productivity of capacity in cloud.

II. LITERATURE REVIEW

In surviving framework when we are transferring the records in to the framework, on the off chance that that document is as of now existed in that framework, at that point that record won't be transferred and rather than that the reference will be made so that if number of times one document referenced to numerous documents on the off chance that by chance that record has erased, at that point we will harm the reference of the all documents so thus we are making the model of that records in the different areas of the framework memory. So on the off chance that one document is erased from the framework memory different areas will deal with the duplicate of that record. By utilizing Secure Hash Table Technique [1].

In another pervious paper, propose POD, an execution masterminded duplication scheme, to improve the execution of fundamental amassing structures in the Cloud by using data duplication on the I/O approach to delete abundance form requests in Like manner saving additional room

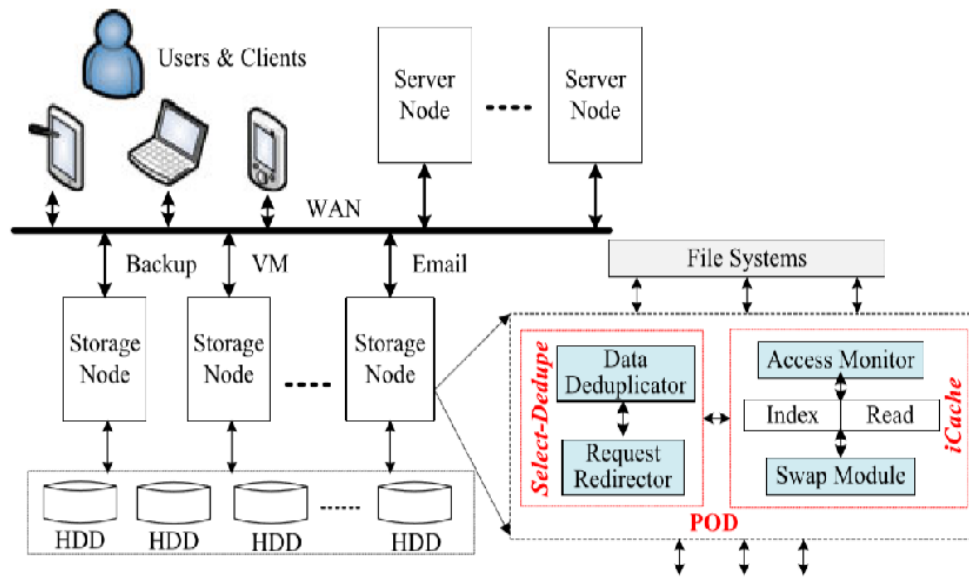

Figure 1: System architecture of POD

Unit comprises in the capacity hub and associate with the File Systems by means of the standard read/compose interface. Along these lines, POD can be effectively fused into any HDD-based essential stockpiling frameworks to propel their framework execution. Unit is independent of the upper file frameworks, which makes POD progressively pliant [5], [6].

Case has two fundamental parts: Select-Dedupe and iCache. The solicitation based Select-Dedupe incorporates two individual modules: Data Deduplicator and Request Redirector. The Data Deduplicator module is at risk for breaking the approaching composes information into information squares, figuring the hash estimation of every datum square, and deciding if an information square is excess and well known. The Request Redirector module decide if the compose solicitation ought to be deduplicated, and keeps up information adaptability to keep the referenced information from being overwritten and refreshed. The iCache module additionally incorporates two individual modules: Access Monitor and Swap Module [2]. The Access Monitor module is in charge of observing the profundity and hit rate of the approaching read and compose demands. The Swap module powerfully addcomodate the store space segment between the file reserve and read reserve. Besides, it swaps in/out the reserved information from/to the back-end stockpiling.

III. PROPOSED OBJECTIVE

In this paper, we utilized two techniques for discovering duplication of the picture. There are two procedures:

- Colour Layout Descriptor
- Edge Histogram descriptor

3.1 Color Layout Descriptor

A shading format descriptor (CLD) is intended to kidnapping the spatial dissemination of shading in a picture. The element destruction process comprises of two sections; framework based agent shading determination and discrete cosine change with quantization.

The CLD catches the spatial format of the delegate hues on a lattice superimposed on a locale or picture. Portrayal depends on coefficients of the unmistakable cosine change (DCT). This is a strong descriptor being very productive in quick perusing and inquiry applications. It tends to be upheld to even now picture just as to video portions. Is intended to catch the spatial transfer of shading in a picture the component annihilation process comprises of two sorts;

- Grid based delegate shading determination.
- Discrete cosine change with contiazation.

The usefulness of CLD is fundamentally the coordinating - Image to picture matching CLD is a standout amongst the most exact and quick shading descriptor [8].

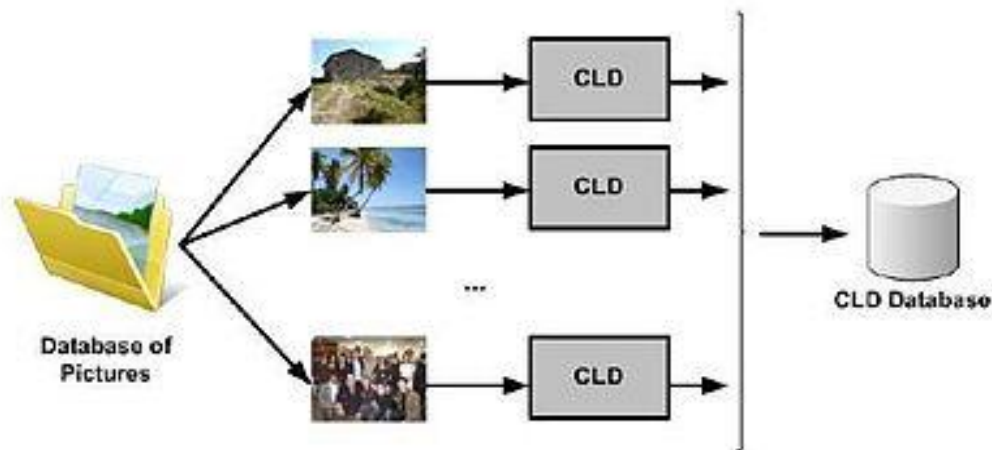
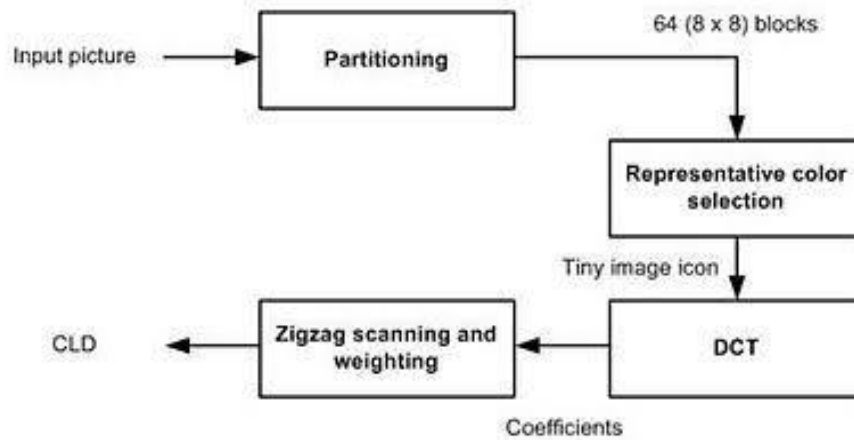

Figure 2: Colour Layout Descriptor

3.2 Edge Histogram Descriptor

The edge histogram descriptor (EHD) is one of the by and large utilized strategies for shape location. It generally speaks to the overall recurrence of frequency of 5 kinds of edges in every neighborhood a sub-picture or picture square. The sub picture is characterized by separating the picture space into 4x4 Non-covering hinders as appeared in figure 1. Along these lines, the partition of picture unquestionably makes 16 measure up to estimated squares paying little mind to the span of the first picture. To characterize the substances of the picture square, we at that point build up a histogram of edge flow for each picture square. The limit of the picture square are classified into 5 types: vertical, even, 45-degree corner to corner, 135-degree askew and non-directional edges, as appeared in Figure 2. Consequently, the histogram for each picture square fill in as the general transfer of the 5 kinds of edges in the comparing sub-picture.

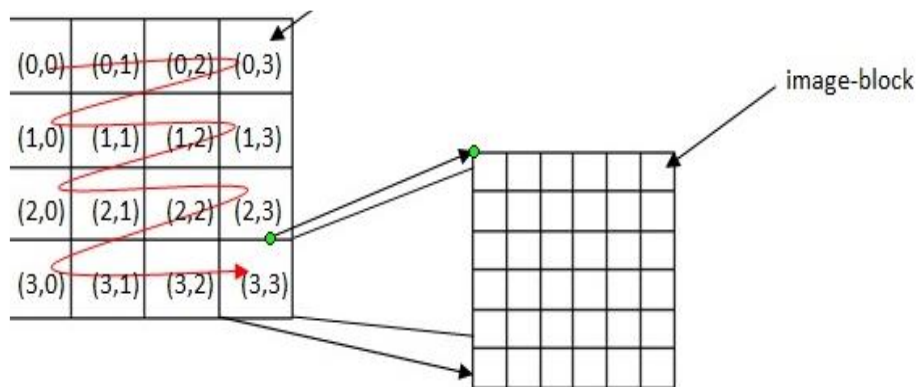

Figure 3: Definition of Sub-image and Image- block in the EHD

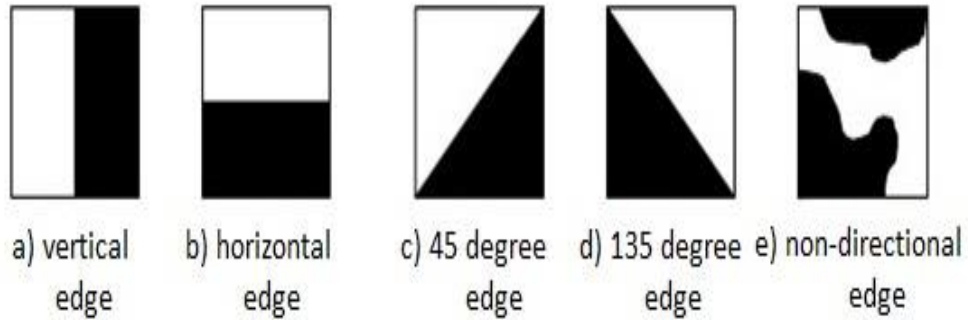

Figure 4: Five Types of Edges in EHD

IV. IMPLEMENTATION

The following flowchart shows overall implementation.

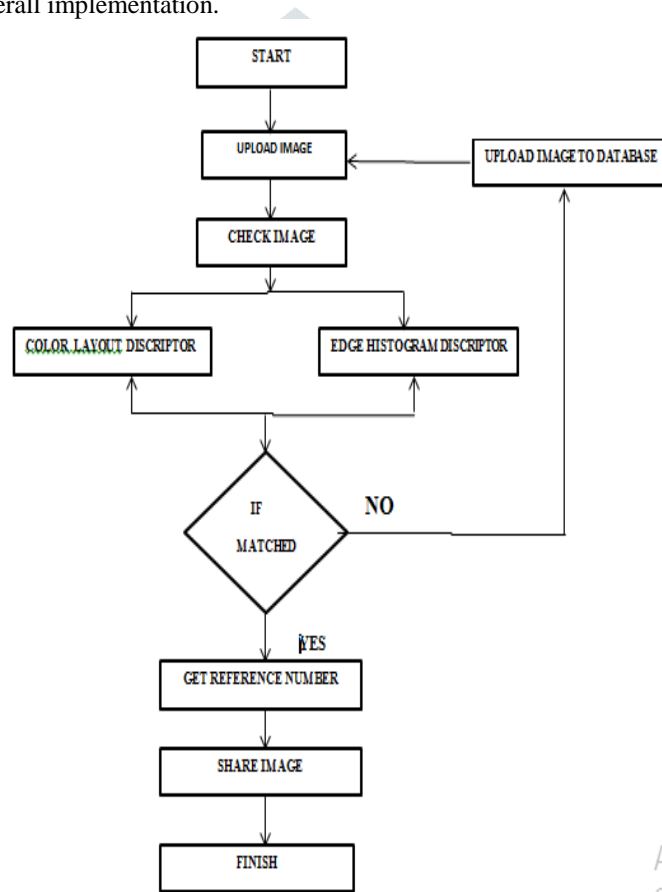

Figure 5: flowchart

V. ADVANTAGES AND DISADVANTAGES

5.1 Advantages

- It requires less capacity as it is information correlation application.
- It recuperates time.
- Adequate and speedy access.

5.2 Disadvantages

- recommended Internet :
- For the absolute execution of this task obligatory the web.

Act
Go t

VI. CONCLUSION

In this paper, we present CLD and EHD methods, an execution situated duplication plot, to build the execution of capacity frameworks in the Cloud by utilizing information duplication demands while likewise sparing extra room. In this paper we considered about the design and execution of information duplication to improve the productivity of capacity in cloud. This framework, machines remote information access to servers. A diverse component for us is expelling the information duplication away plan by utilizing electronic application.

REFERENCES

- [1] k. Lavanya, Dr. A. Sureshababu, "Data Reduction using A dedplication attentive Resemblance Detection & rejection Scheme" International Journal of Advance Research in Computer Science and Management Volume 5, Issue 8, August 2017.
- [2] Bo Mao, Hong Jiang, Suzhen Wu and Lei Tian, "Leveraging Data Deduplication to Improve the Performance of Primary Storage Systems in the Cloud" IEEE TRANSACTIONS ON COMPUTERS, VOL. 65, NO. 6, JUNE 2016.
- [3] A. T. Clements, I. Ahmad, M. Vilayannur, and J. Li, "Decentralized deduplication in SAN cluster file systems," in Proc. Conf. USENIX Annu. Tech. Conf., Jun. 2009.
- [4] K. Jinand and E. L. Miller, "The effectiveness of deduplication on virtual machine disk images," in Proc. The Israeli Exp. Syst. Conf., May 2009.
- [5] D. T. Meyer and W. J. Bolosky, "A study of practical deduplication," in Proc. 9th USENIX Conf. File Stroage Technol., Feb. 2011.
- [6] K. Srinivasan, T. Bisson, G. Goodson, and K. Voruganti, "iDedup: Latency-aware, inline data deduplication for dominant storage," in Proc. 10th USENIX Conf. File Storage Technol., Feb. 2012.
- [7] A. El-Shimi, R. Kalach, A. Kumar, A. Oltean, J. Li, and S. Sengupta, "Primary data deduplication-large scope study and system architecture," in Proc. USENIX Conf. Annu. Tech. Conf., Jun. 2012.
- [8] D. Meister, J. Kaiser, A. Brinkmann, T. Cortes, M. Kuhn, and J. Kunkel, "A study on data deduplication in HPC storage scheme," in Proc. Int. Conf. High Perform. Comput., Netw., Storage Anal., Nov. 2012.

