

# DESIGN AND DEVELOPMENT OF ELECTRIC BIKES

<sup>1</sup>Sunil kumar A V, <sup>2</sup>Yashas H S and <sup>3</sup>Yogesh N

Department of electrical and electronics, Acharya Institute Of technology, Bangalore

**Abstract:** The motivation for the use of electrical vehicles is that they will not emit any of the harmful gases. Whereas electric bicycles are the best mode of transportation due to their low cost to travel a distance compared to the other mode of transportation in urban areas. Whereas they have their own disadvantages like they are expensive to buy and not suitable to travel to long distances and the speed is also limited and quick refueling is also not possible.

In this paper describes a conversion of the normal engine bike into fully functional electrical vehicle. This vehicle utilizes the LI battery as a source, BLDC (brush less DC motor) to drive the vehicle, speed controller, and drum brakes and other required for conversion. The test shows that the vehicle can deliver higher fuel economy. This paper presents an overview of a prototype vehicles which can able to use the electricity as a fuel and helps in energy saving and clean environment solution.

**Keywords**—Electric bikes(E-bikes), LIBattery (lithium ion), BLDCmotor (brushless dc motor), drumbrakes

## I. INTRODUCTION

The main concerns over environmental concerns where the diesel and petrol vehicles are causing the huge impact where they are polluting more and more and the fossil fuels are also going to extent where to reduce all of this problems the electric vehicles are the best mode of transportation in cities and urban areas.

Electric vehicles are being researched to satisfied the same performance of fossil fuel vehicles. Besides it's a green mode of transportation, where the E-bikes are efficient and do not emit anything and quite operation.

The electric vehicles are the key to the dependency and use of the fossil fuels. And there is a need for an exploration of natural resource of energy and power which are non-conventional source of energy and electricity is one of the best mode of renewable energy source.

The basic principal of these vehicles is to use the energy that is in the battery during travel and BLDC motor is used to drive the vehicle.

## II. LITERATURE SURVEY

Chyi-Ren Dow, Van-Tung Bui, Chao-Ying Chen, and Shioh-Fen Hwang mentioned in "An Energy Management System for e-Bikes"

Electric bicycles contain many different components such as motors, motor controllers, batteries, chargers throttles and other speed sensing sensors etc. In order to improve the performance of all the electric equipment's maintenance systems, the communication mechanisms and interfaces among components are important research issues in this paper. In an electric bike, the battery is one of its important component. In order to give the user a good ride experience in the bike, there are three modes for the rider, including eco mode, city mode and power mode.

The eco mode can be selected when the rider wants reduce the battery consumption. It can take a long time to drain the battery to drive BLDC motor. rider who ride bike do not have to worry about the battery drain. Even in the eco mode and city mode can not produce the enough torque for some hilly area so there will be another power mode where it will solve the problem.

N. Pavan Kumar Reddy, K.V.S.S Vishnu Prasanth in "Next Generation Electric Bike", Mentioned about how to design a vehicle according to the competition the points are has to be consider in order to satisfy the competition criteria's as well as for the better performance of the vehicle on the track and for the rider also. Such as High strength, safety, Low weight, Ease of manufacturing, Low cost, higher efficiency, long life.

All the topics presented in this paper has been supported by Calculations, 3D CAD models and FEA data and charts in the paper and discussed on the type of material used, tube management, Frame for e-bike and assembly of parts are explained in this paper.

## III. HARDWARE COMPONENTS (ELECTRICAL PARTS)

The hardware is mainly consists of the BLDC motor, motor controller, charger, throttle and battery the power obtained by the battery is to run the motor where the battery is get charged by the charger through 230 volts supply and some of the hardware components are discussed below.

The motor is mainly high torque 48 volts 750 watt 16amp BLDC motor with inbuilt gear box.

The controller used for this PWM controller with 3speed variation that is low medium and high.

Throttle specification -48volts, temperature 20' to 80'and size of 13\*3.3cm.

The battery is of lithium ion type which is of 48volts 65 Ah with battery management system which protect the battery from short circuit and over charging of the battery.

## IV. CALCULATION

Weight = 140kg

Velocity = 40kmph

=12.5mps

Time to reach maximum speed = 6sec

Dimension of the wheel = 3.00 x 18

Accelerations = velocity/time

= 12.5/6

=2.08m/s<sup>2</sup>

Radius of the wheel=2.1m

Force = weight \* acceleration

$$= 140 * 2.08$$

$$= 219.2N$$

Torque = force \* radius of the wheel

$$= 219.2 * 2.1$$

$$= 611.52Nm$$

Linear distance travelled =  $2\pi$ \*radius of the wheel

$$= 2\pi*2.1$$

$$= 13.188m$$

Rotation Per Minute(RPM) = Total distance covered per hour/linear distance=  $40000/(13.188*60) = 505.51RPM$

**v. BLOCK DIAGRAM**

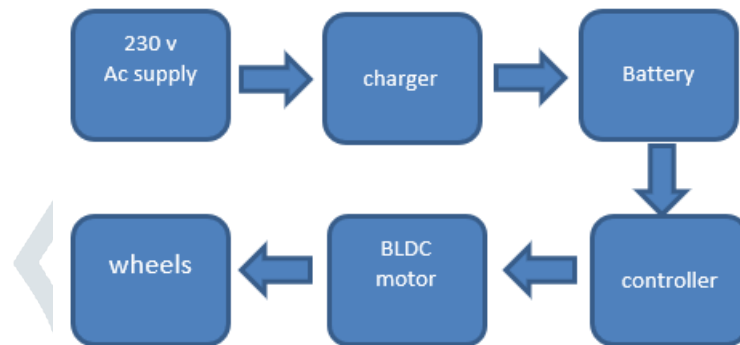

Fig 4.1 Block diagram of the electric bike

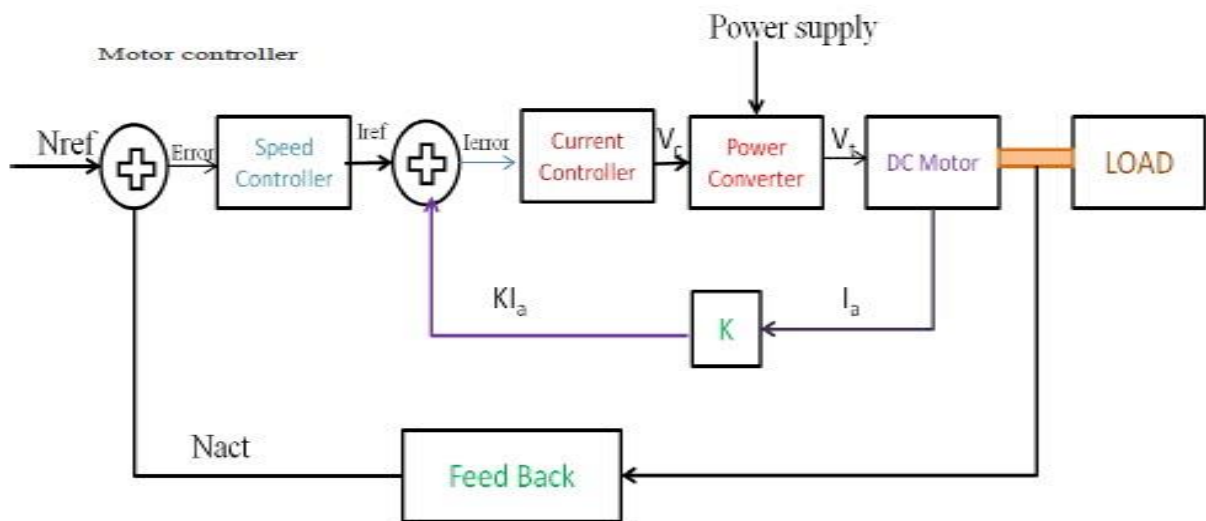

Fig 4.2 Block diagram of the motor controller

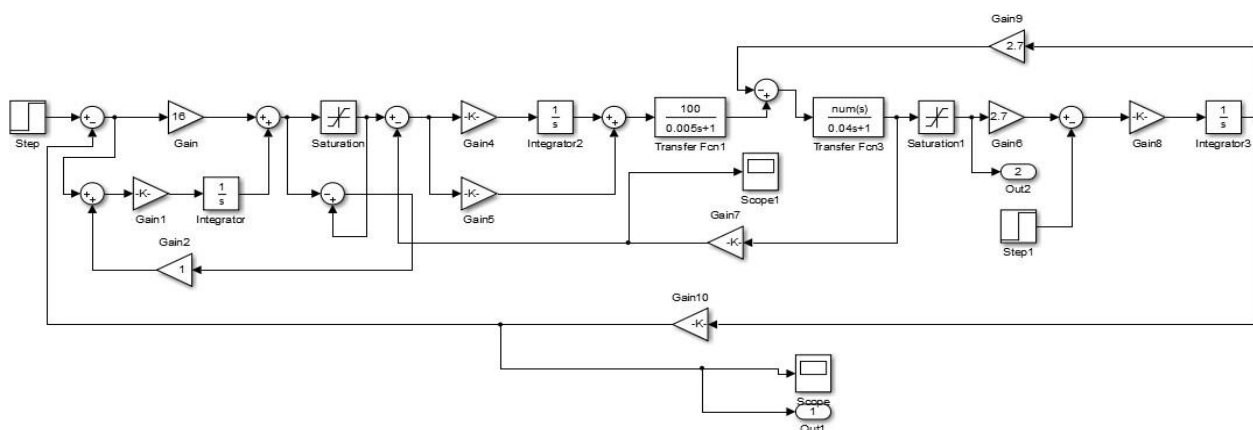

Fig 4.3 Simulation model of motor controller

The block diagram of the motor controller and the simulation model are shown in the fig. 4.2 and 4.3 respectively. In the block diagram, it consists of current controller, speed controller, converter and motor as shown. Since current controller and speed controller are PI type controller.

## VI. METHODOLOGY

At first all the circuits are done using stimulation (protues 8 software, MATLAB) in the software mainly the motor control and charging part is stimulated and verified to find out the errors in the circuit and rectify it before going to hardware assembly. After simulation is complete the components are assembled in the breadboard and circuit is verified. After verifying in hardware, the pcb design is done by the same software. (protues 8 software)  
The pcb design is printed on the pcb board and hardware components are assembled and soldered and verified its working. The hardware part is designed using CADD software and implemented with hardware parts. All the parts are assembled and tests are has to be conducted.

## VII. CONCLUSION

In this paper design and implementation of electric vehicles and also hardware model has been tested and got very good efficiency on road. Results of simulation and hardware given very convenience speed control for electric bike.

## VIII. REFERENCE

1. F. Pellitteri, V. Boscaino, A.O. Di Tommaso, F. Genduso and R. Miceli, "E-bike battery charging: methods and circuits", \*Sustainable Development and Energy Saving Laboratory, Department of Energy, Information engineering and Mathematical models, University of Palermo, viale delle scienze, building 9, 90128, Palermo, (Italy) \*\*Power Applications Laboratory, Department of Energy, Information engineering and Mathematical models, University of Palermo, viale delle scienze, building 9, 90128, Palermo, (Italy)
2. N. PAVAN KUMAR REDDY, K.V.S.S VISHNU PRASANTH, "Next Generation Electric Bike", published in 2017
3. Chyi-Ren Dow, Van-Tung Bui, Chao-Ying Chen, and Shiow-Fen Hwang, "An Energy Management System for e-Bikes", {crdow, P0477624, M0419380, and sfhwang }@fcu.edu.tw.
4. Ian Vince McLoughlin, I. Komang Narendra, Leong Hai Koh, Quang Huy Nguyen, Bharath Seshadri, Wei Zeng, Chang Yao, "Campus Mobility for the Future: The Electric Bicycle", published in 2012.