

AUTOMATIC SOLAR GRASS CUTTER WITH COLLECTOR

¹Arun Kumar VB,¹ Manjunath S,¹Najeebulla Shariff,¹Sagar V, ²Dr.Rashmi S
¹UG Scholar, Department of EEE, Vidyavardhaka college of Engineering, Mysuru, India
²Asst. Prof, Department of EEE, Vidyavardhaka college of Engineering, Mysuru, India

Abstract: Automatic grass cutter with collector performs the operation of grass cutting and collecting automatically. This project will help to overcome the difficulty of the existing internal combustion engine grass cutter. The main point of the model is to run the model using renewable energy to eliminate the pollutant gases formed by the IC engine. Our idea is to improve the existing model by adding collector to collect grass after cutting and for controlling of various operations like cutting the grass,collecting the grass,moving the robot we are using arduino uno, for detection of the obstacles ultrasonic sensor is being used. The power supply is given from the battery and battery is charged by solar panel through solar charger controller. This can be operated automatically and also manually by using Bluetooth where bluetooth module is with arduino uno.

Keywords–Solar panel, arduino uno,dc motors, ultrasonic sensor, bluetooth module

I. INTRODUCTION

Nowadays, due to increase in the use of fuel based machines there is an increase in the pollution all over the world. Also the cost of the fuel is increasing hence it is not efficient. In the time where the technology is merging with environmental awareness, consumers are trying every day and night to contribute for the elimination of the carbon footprints. The main cause for the pollution is human beings which can be seen in day to day life.This project automatic solar grass cutter with collector will help the consumer from cutting the lawn and it will reduce hazardous gases created due to it. This design helps to eliminate the problems which are caused by conventional IC engine grass cutter.

The fully automatic solar grass cutter with collector is a grass cutting unmanned vehicle with collector powered by solar power which avoids the obstacles and changes direction without human interference. The system uses the 12V battery to power the geared motors, grass cutter and collector motor. It is installed with solar panel for charging the battery so no need of charging it by externally. The cutting motor, collecting motor and geared motors are interfaced to the arduino uno that controls the operation of all the components. It is also interfaced with an ultrasonic sensor for the detection of the object, the arduino uno drives the vehicle in the previous direction if no obstacle is being detected. On the detection of the object ultrasonic sensor will send signal to the arduino and the robot takes deviation to avoid any damage to the objects /humans/animal. The robot rotates according to the delay provided and then moves the grass cutting vehicle in the forward direction again.

The system uses arduino uno, battery, dc motors, ultrasonic sensor, solar panel and collecting brush. Main power of the system is solar panel which is used to charge the lithium ion battery. This battery will provide the power supply to a regulator then to the arduino and also the dc motors and the sensors. The dc geared motors are used to move the grass cutting machine and high speed dc motors used to rotate the trimmer wire and collector brush. The sensor gets its supply voltage from arduino uno, by using the sensor inputs the arduino decides the lawn mower operation.

II. LITERATURE REVIEW

In 1830 Edwin Budding invented the first ever grass cutter just outside of surround, in Gloucestershire, It was designed mainly in order to trim the grass of extensive gardens, first machine of Bedding was of 19 inches (i.e. 480mm) wide with a wrought iron frame. Also the mower has to be pushed from the behind.[1] Therefore an automatic solar grass cutter with collector is robotic machines that will use sliding wires to cut the lawn.[2] Also the power consumption becomes the essential for the future aspect. The solar grass cutter robot is a user friendly device which will be very simpler in the construction type and also it is being used to maintain as well as upkeep lawns, college's, playgrounds etc.[3] This research work mainly aims at the fabricating a solar panel for operating the grass cutting machine. This paper mainly focuses on the use of solar powered automation of the grass cutting robot to eliminate man power. Unlike the other lawn mower in the market available, this design will require no fuel for the maintenance of the robot and manual mode requires less human interaction. Through an array of the sensors safety takes a major consideration in the devices, this robot will be not only stays on the lawns, it will be also avoid and detect the objects, humans by a ultrasonic sensor. [4] Usually this is prepared as a wireless grass cutter that is used with solar panel so therefore no external source is needed and battery supplies constant voltage even when the robot is in working condition. [5] The solar panel installed on top of the robot helps to generate electricity which is used to charge the battery. A driver must be used for controlling the speed and action of the motor as per the requirement.[6] The solar panel are placed such that in order to absorb the high intensity from the sun and it will incline exactly at 45°. [7] For the collection of the grass which has been cut a box is being placed with rolling brush over the grass cutter so that the cut grass put into the box and also outside the lawn. It is light in weight and also compact design [8].

III. OBJECTIVE

The main point of the project is to operate the robot on solar energy hence eliminate hazardous gas and reduce the manpower. Project uses an arduino uno for controlling various operation of grass cutter. Also the grass cutter has ultrasonic sensor for obstacle detection, collector for collecting the grass. It does not require any skill person as it operates automatically.

IV. HARWARE REQUIRED

3.1 Arduino Uno

The brain of the system is Arduino uno. The Fig shows Arduino uno. Arduino uno consists of a microcontroller board with an on chip ATmega328microcontroller. It is having 14 digital pins;all 14 pins may be used as outputs of PWM, analog input pins – 6nos,a reset push button, a USB connection port,a 16 MHZ oscillatorand a power jack. It can either be connected with a regulator or it can be connected to a USB port of the computer.

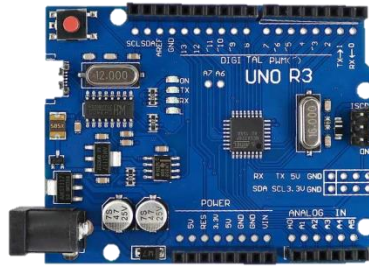

Fig 1: Arduino Uno

3.2 DC motors

An electrical machine converts an electrical form of energy into mechanical form of energy. Many types of machines depends upon the forces of magnetic field. The dc motor direction of rotation can be switched by swapping the input terminals of the motor. Project is equipped with a low speed dc geared motor and high speed motors.



Fig 2: DC Motors

3.3 Speed controller

Electronic speed control is circuit which helps to control the direction and speed of the motor. It is having an option to reverse the direction and has braking system. Radio controlled models uses miniature esc. This system is used in large electric vehicles for speed regulation.

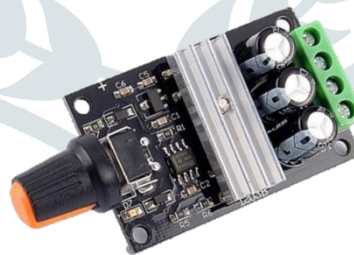

Fig 3: Speed controller

3.4 Collector brush

Collecting brush is a customized hardware. It is similar to the roller brush which collects dust and other particles in industries. It is used to collect the grass from the lawn after the grass cutting.



Fig 4: Collector Brush

3.5 Trimmer wire

A trimmer wire is the similar wire which is used in the IC engines. Here a wire of 20cm length is used to cut the grass. The type of material used is nylon.

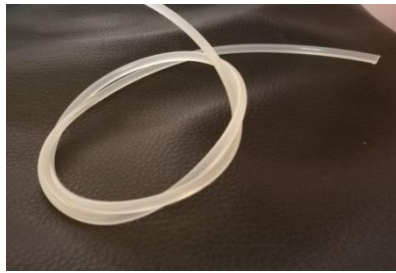

Fig 5: Trimmer wire

V. WORKING

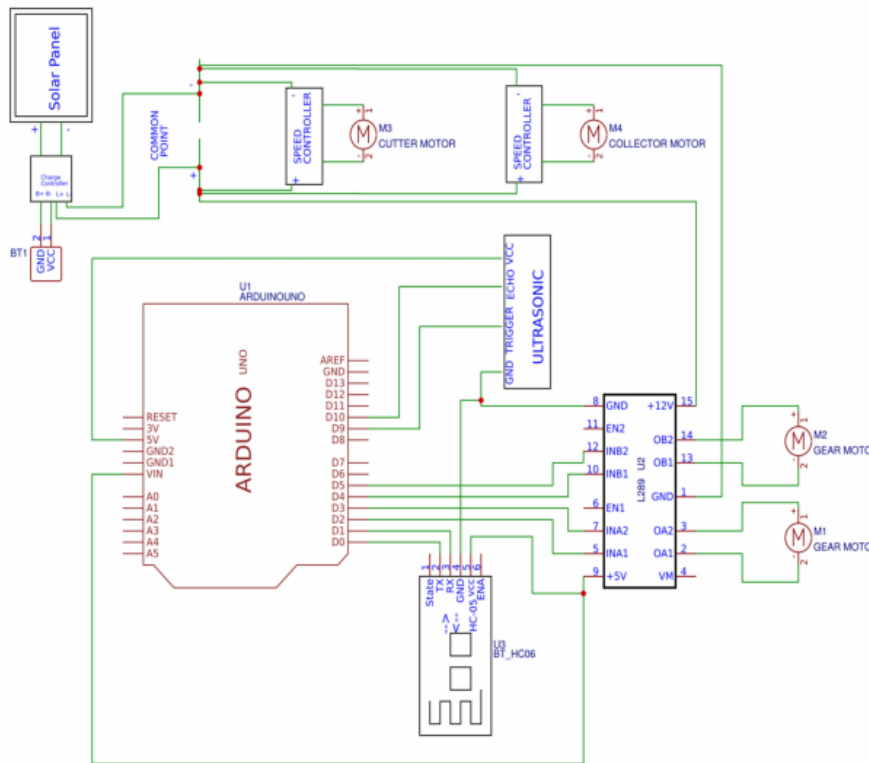

Fig 6: Schematics

Project is equipped with arduino uno which controls all the actions of the robot. To start the robot it is turned on using the Bluetooth app. On turning on of the robot arduino will send signal to the wheels the robot starts to move simultaneously the cutting motor and collecting motor will turn on. The process will continue till any object is detected then the robot will turn left/right accordingly, after taking turn the process will be continued till it finds an obstacle this process is made as a loop. If the collector box is filled with grass the robot is switched into manual mode and it is controlled using the bluetooth app for dumping the grass. The above cutting and collecting operation can be made manually if the lawn is in unusual shape.

VI. BLOCK DIAGRAM

Block diagram gives a brief working of the robot to understood better. Solar panel captures solar energy and reserves the energy in battery. This energy will be used by the cutter and collector. The ultrasonic sensor senses any object and the robot takes other diversion. The trimmer wire cuts the grass and the collector helps to collect the grass into the collector box.

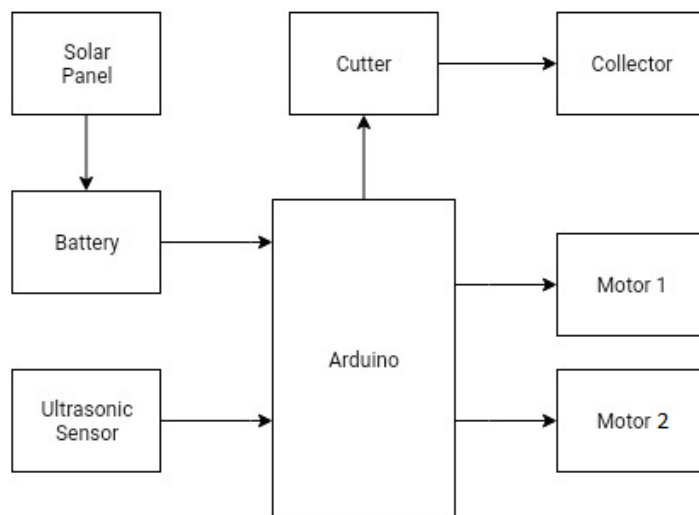

Fig 7: Block diagram

VII. FLOW CHART

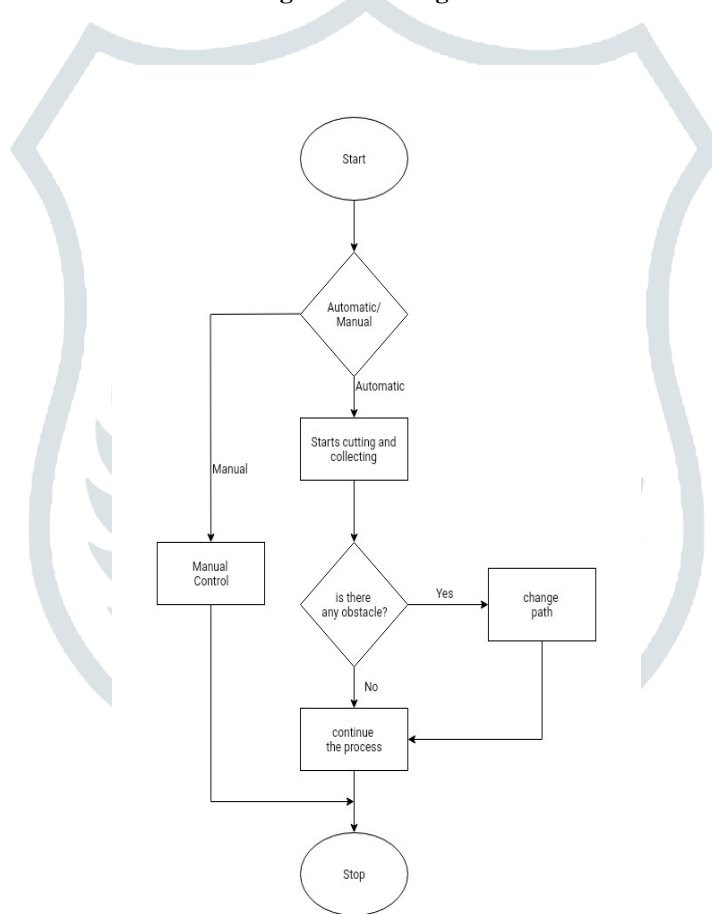

Fig 8: Flow Chart

VIII. BENEFITS

- Compact size and portable
- No fuel cost
- Pollution free
- Low maintenance
- Low initial cost
- Grass will be collected automatically
- Manual operation by bluetooth control

X. APPLICATION

- Public Parks

- Play area(Cricket/football ground)
- Gardens of house
- Lawns in industries

XI. RESULT

The prototype built was able to cut the grass and collect the grass efficiently. The time required to complete the grass cutting is less compared to other grass cutter and the work looks neat as the grass cut was collected simultaneously. The battery takes 12 hours to reach 100% through solar panel at a constant charging rate of 0.8A, which is sufficient as the mower is not required all the time.



Fig 9: Model

XII. CONCLUSION

Our project entitled Automatic solar grass cutter with collector is completed successfully and was able to cut and collect grass simultaneously. As it is more advantages over the conventional IC engine it can be used by a common man easily. This robot is easy to handle and does not require skilled persons to operate. The system is able to charge the battery even when the model is in operating condition. After cutting the grass there is a collector provided to collect the grass by running the collector motor. Since here we are using battery we can operate continuously without any distortion. Motor speed is controlled by adjusting using speed controller.

XIII. REFERENCES

- [1] "Smart Solar Grass Cutter Robot for Grass Trimming" by Ashish kumar chaudhari, Yuvraj sahu, Pramod kumar sahu, Subhash Chandra verma
- [2] IJIRST "Modification of Solar Grass Cutting Machine "by Praful P.Ulhe, Manish D. Inwante and Fried D. Wankhede Krushnkumar S.Dhakte
- [3] "Design and implementation of Automatic Lawn Cutter" by Pratik Patel, Ashwini Bhosale, Prof.Sheetal Jagtap.
- [4] Srishti Jain, Amar Khalore, Shashikant Patil. Self-Efficient and Sustainable Solar Powered Robotic Lawn Mower in International Journal of Trend in Research and Development(IJTRD). Vol.2(6), December 2015.
- [5] Tao Liu, Bin Zhang, Jixing Jia, Electromagnetic navigation system design of the green house spraying robot, IEEE(2014).
- [6] Gholap Dipak Dattatraya1, More Vaibhav Mhatarde, Lokhande Manojku-mar Shrihari, Prof. Joshi S.G Robotic Agriculture Machine, International Journal of Innovative Research in Science, Engineering and Technology, Volume 3, Special Issue 4, April 2014.
- [7] Sajjad Yaghoubi, Negar Ali Akbarzadeh, Shadi Sadeghi Bazargani, Sama Sadeghi Bazargani, Marjan Bamizan, Maryan Irani AS1 , Autonomous Robots for Agricultural tasks and farm assignment and future trends in Agro Robots, IJMMIENS Vol.13 No.03(2013).
- [8] K. Prema, N.Senthil Kumar, S.S.Dash ,Sudhakar Chowdary, Online control of remote operated agricultural Robot using Fuzzy Processor and Virtual Instrumentation, IEEE(2012).
- [9] John Billingsley, Agricultural Robotics , IEEE Robotics Automation Mag-azine (2009).