

DESIGN AND FABRICATION OF POWER TRANSMISSION THROUGH ELBOW MECHANISM

Mr.Ashok M R
Production Engineering(Asst.Prof)
Sri Sairam Engineering College
Chennai,India

S Raghul
Production Engineering(Student)
Sri Sairam Engineering College
Chennai,India

P Siddharthan
Production Engineering(Student)
Sri Sairam Engineering College
Chennai, India

Suyambu lingam
Production Engineering(Student)
Sri Sairam Engineering College
Chennai, India.

Abstract - Power transmission for skew shafts is with the help of either crossed helical gear or worm gear or hypoid gears in a machine, but the manufacturing of these gear is very complex, power loss in gears due to sliding motion and the shaft orientations is very limited, so need arises for a better system. In Gearless power transmission for skew shafts which reduce the losses, cost & save the time and space. This system allows the changing in the orientation of shafts during motion which is very interesting and fascinating about this mechanism. In this transmission system no. of pins or links used must be odd 3,5,7,9... Pins or links are fixed in the drilled holes at the both shaft ends due to which motion is transferred. The Working of this arrangement is very smooth & work effectively with a very minimum amount of power losses, which is skillful and is having something precise in transmitting power at right angle without any gears being manufactured.

Key Words: Gearless mechanism, Skew shaft, Component of the model and its operation, Design of Shaft, Hub, Elbow rod.

1. INTRODUCTION

Today's world requires speed on each and every field. Hence rapidness and quick working is the most important. Now days for achieving rapidness, various machines and equipment's are manufactured. Gears are costly to manufacture. Its need to increase the efficiency of transmission which cannot be done using geared transmission. Gearless transmission mechanism is capable of transmitting power at any angle without any gears being manufactured.

So here I introduced a gearless power transmission system for skew shafts which reduce the losses, cost & save the time and space. This system allows the changing in the orientation of shafts during motion which is very interesting and fascinating about this mechanism.

Also during analysis of mechanism and working it is seen that this gearless transmission can be used for both intersecting shafts and skew shafts but here we introduced a solution for skew shafts so main attention is towards the skew shafts.

2. Components of the model and operations

In this section different views of the arrangement and the components used for arrangement are shown, which is necessary for understanding the proper working and setup of the arrangement.

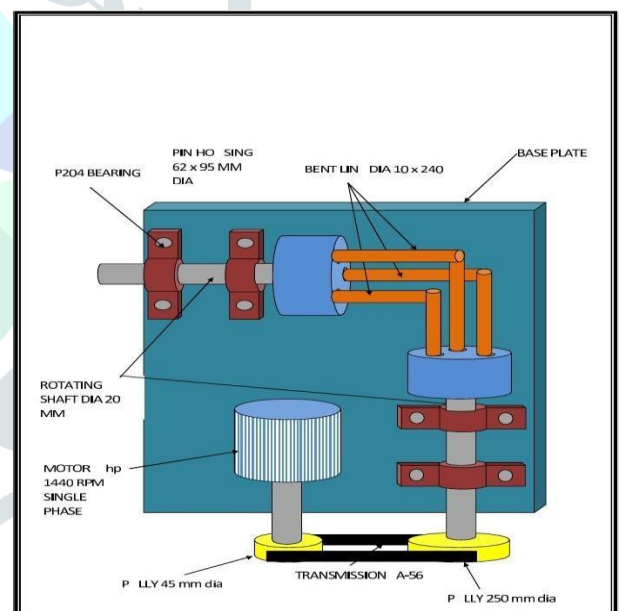

Fig-1: Concept Drawing of Machine

A. View of planes

Here in the below diagram, planes are shown in the 3D, which helps us in the understanding of the mechanism and movement of shafts and link used.

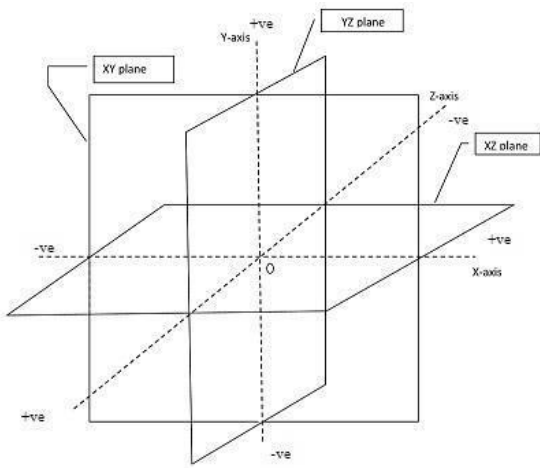

Fig-2: View of the planes

B. View of the shafts

Below diagram shows a different view of the shaft arrangement which are skew and angle between them is 90 degrees, which helps us in the understanding of the arrangement of shafts. In below figure (a) front view (b) side view (c) top view.

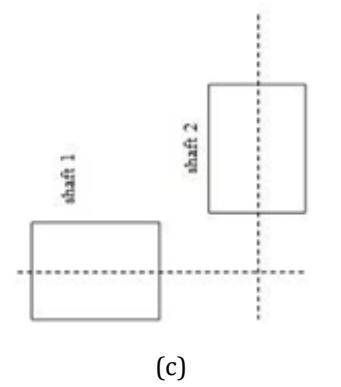
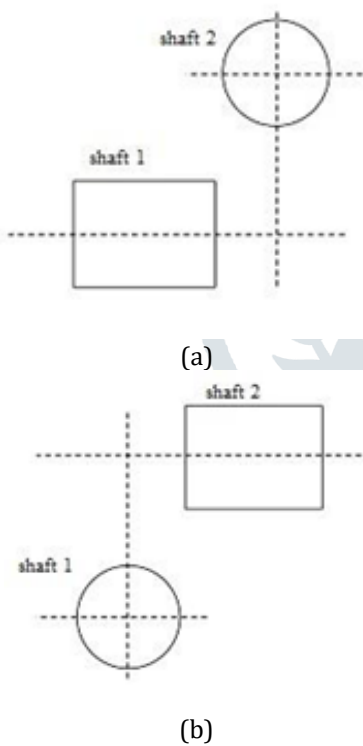
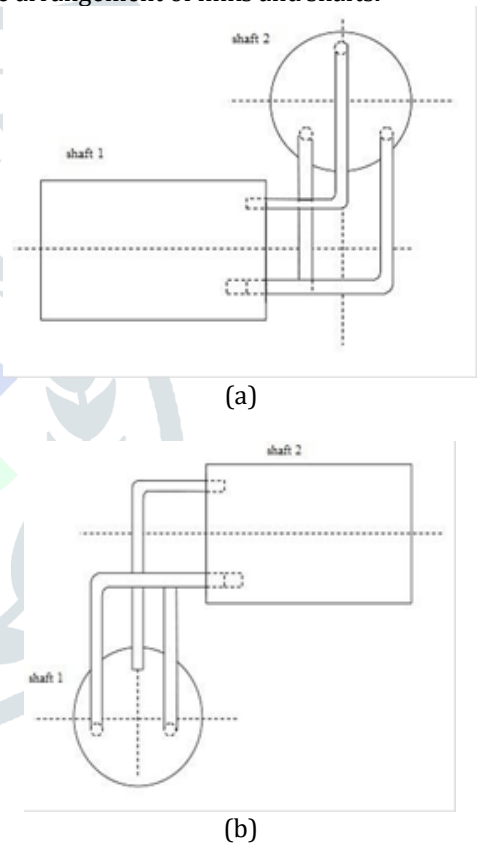

Fig-3: View of Shafts Arrangement

C. Views of Setup

Different views of the setups are shown in Figure (a) Front view. (b) Side view (c) Top view. These views show the arrangement of links and shafts.



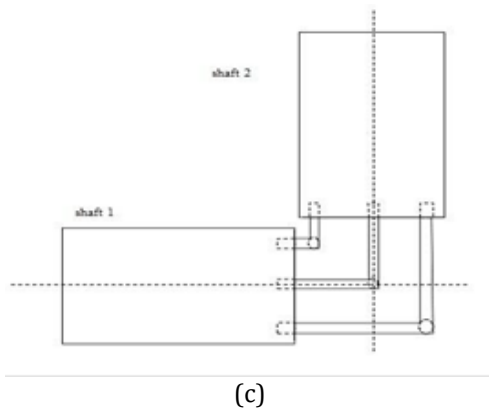

Fig-4: View of the setup

D. Views of the Pins

Here different views of the pins according to the setup are shown (a) Front view (b) Side view (c) Top view. These pins are used for transmitting the power when there is no change in orientation of shafts during motion.

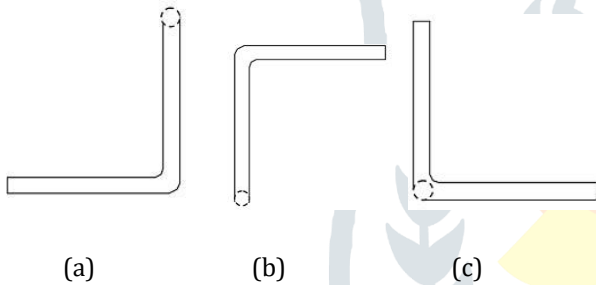

Fig-5: View of pins

E. Arrangement of Pins in Shaft

In the below diagram for basic arrangement of pins in the shaft holes are shown. The diagram clearly shows that pins used are in odd no.3, 5, 7, 9... and centers of any two pin holes must not be on that line which represent the diameter of the shaft and angle between all consecutive holes should be equal for smoother power transmission. Value of angle such that it's multiple with any integral not equal to 180 degrees.

Let the Value of angle = x degree, then $n \cdot x \neq 180$ degree. Where n is an integral value.

As mentioned, Angle between the centers of any two pin holes must not be on that line which represent the diameter of the shaft because if this happen angle between them is 180 degrees and during motion pins or links use are trying to overlap each other because of this motion interrupted. Also, as we mentioned that pins no. should be odd and angle between consecutive holes are equal so it can be easily understood by below table that why it is necessary.

Table no.1: Arrangements of pins in shafts

No. of pins	Angle between consecutive hole(degree)	Angle between consecutive hole(degree)	Value of integral
2(even)	180	Yes	1
3(odd)	120	No	No integral
4(even)	90	Yes	2
5(odd)	72	No	No integral
6(even)	60	Yes	3
7(odd)	51.43	No	No integral
8(even)	45	Yes	4
9(odd)	40	No	No integral

In upper table it is seen that with any no. of pins other than odd there must be an integral whose multiplication with angle gives the value 180 degrees so only odd no. of pins used.

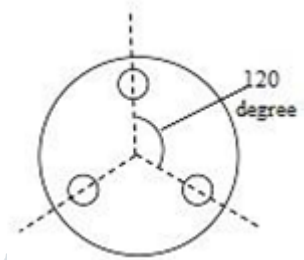

Fig-6: View of Shaft with Holes

F. Analysis of Mechanism

From the above diagrams and views the setup is clearly established in the mind, but as for convenience here we use the front view of the setup for analyzing the mechanism of setup.

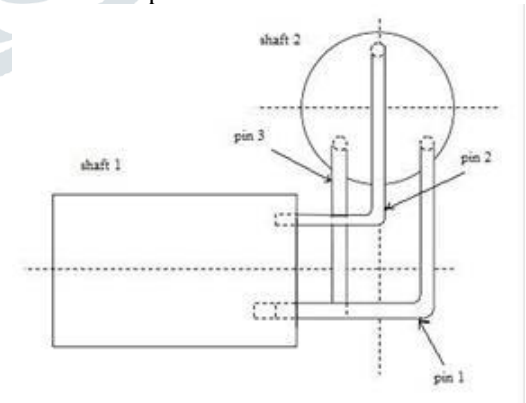

Fig-7: Setup

Let at the starting instant shaft 1 starts rotation with 3 pins in anticlockwise direction and a reaction force developed at the pin surface which in contact with the shaft and this force transferred to the other end of the pin which is in the shaft and applying on the shaft 2 due to which shaft 2 starts rotating in the same direction as shaft 1, after 120 degree rotation pin 1 comes at the place of pin 2 & pin 2 comes at the place of pin 3 & pin 3 comes at the place of pin 1 by sliding in shaft and self-adjusting. This motion repeated for next 120 degrees and further for next 120 degrees and pins are exchanging the position in successive order as discussed before.

3 DESIGN CALCULATIONS

Testing of the machine and for functioning

Power of motor = $\frac{1}{4}$ H.P = $746 \times 0.25 = 186.5$ N- m/s

Rpm of motor N = 1440 rpm

Power of motor P = 186.5 watt.

$$P = 2 \pi N TP / 60 \text{----- (Eq.1)}$$

Where, N = Rpm of motor = 1440

T = Torque transmitted

From eq.1 we get,

$$186.5 = 2\pi \times 140 \times T / 60$$

$$T = 1.23 \text{ N-m}$$

$$T = 1238 \text{ N-mm.}$$

DESIGNING OF SHAFT

Following stresses are normally adopted in shaft design

Max tensile stress = 60 N/mm²

Max shear stress = 40 N/mm²

Considering 25 % overload

$$T_{\max} = 1238 \times 1.25 = 1.525 \times 10^3 \text{ N-mm}$$

The shaft is subject to pure torsional stress

We know $T = 3.14/16 \times fs \times d^3$

$$15250 = 3.14/16 \times 70 \times d^3$$

$$D = 10.20 \text{ mm}$$

Taking factor of safety = 2

$$D = 10 \times 2 = 20 \text{ mm}$$

A shaft diameter is 20mm and length is 230mm

$$M = 2151.11 \text{ N} \times 230 \text{ mm}$$

$$= 494755.3 \text{ Nmm}$$

Bending stress for shaft

$$\sigma = 32M\pi \times d^3$$

$$= 186.649 \text{ N/mm}^2$$

Tensional shear stress of shaft

$$Mt = 60 \times 106 \text{ kw} 2\pi n$$

Where, Kw = 7.5, n = 120

$$Mt = 596831.03 \text{ Nmm}$$

$$\tau = 16Mt/\pi d^3$$

$$= 16 \times 596831.03 / \pi \times 20^3$$

$$= 112.57 \text{ N/mm}^2$$

DESIGNING OF HUB

Considering a hub of internal diameter is 32mm and outer diameter is 92mm, length is 82mm.

$$p = 100 \times 9.81 = 981$$

$$\sigma_b = pDi^2 / D0^2 - Di^2$$

$$= 980 \times 32^2 / 92^2 - 32^2$$

$$= 135.01 \text{ N/mm}$$

DESIGNING OF EL-BOW ROD

We know that,

Same torque is transmitted to bent link shaft

So torque on each shaft = $T/3 = 15250/3 = 5083$ N mm

$$T = 3.14/16 \times fs \times d^3$$

$$5083 = 3.14/16 \times 70 \times d^3$$

$$D = 7.17 \text{ mm.}$$

Take approximately D = 8mm.

Diameter of rod is 8mm and length is 300mm

$$Z = 0.78R^3$$

$$= 0.78 \times 43$$

$$= 49.92 \text{ kg/mm}^2$$

Bending stress of rod

$$\sigma = PL/4Z$$

$$= 186.5 \times 300 / 4 \times 49.92$$

$$= 280.19 \text{ N/mm}^2$$

4. WORKING

The Gearless transmission or El-bow mechanism is a device for transmitting motion at any fixed angle between the driving and driven shaft. The synthesis of this mechanism would reveal that it comprises of a number of pins would be in between 3 to 8, the more the pins the smoother the operation. These pins slide inside hollow cylinders thus forming a sliding pair. Our mechanism has 3 such sliding pairs. These cylinders are placed in a hollow pipe and are fastened at 120 degree to each other. This whole assembly is mounted on brackets wooden table. Power is supplied by an electric motor. The working of the mechanism is understood by the diagram. An unused form of transmission of power on shaft located at an angle. Motion is transmitted from driving to the driven shaft through the rods which are bent to conform to the angles between the shafts. These rods are located at in the holes equally spaced around a circle and they are free to slide in & out as the shaft revolves. This type of drive is especially suitable where quite operation at high speed is essential but only recommended for high duty.

The operation of this transmission will be apparent by the action of one rod. During a revolution. If we assume that driving shaft "A" is revolving as indicated by arrow the driven shaft B will rotate counter clockwise. As shaft A turns through half revolution C shown in the inner and most effective driving position slides out of both shafts A & B The first half revolution and rod "C" then will be at the top then

during the remaining half this rod "C" slide inwards until it again reaches to inner most position shown in Fig. in the meanwhile the other rods have of course passed through the same cycle of movements all rods are successively sliding inwards and outwards.



Fig-7: Gearless power transmission for skew shafts

Although this transmission is an old one many mechanics are skeptical about its operation, however it is not only practicable but has proved satisfactory for various applications when the drive is for shafts which are permanently located at given angle. Although this illustration shows a right angle transmission this drive can be applied also to shafts located at intermediate angle between (0 and 90 degree) respectively. In making this transmission, it is essential to have the holes for a given rod located accurately in the same holes must be equally spaced in radial and circumferential directions, be parallel to each rod should be bent to at angle at which the shaft are to be located. If the holes drilled in the ends of the shafts have "blind" or closed ends, there ought to be a small vent at the bottom of each rod hole for the escape of air compressed by the pumping action of the rods.

5. COMPARISON WITH EXISTING SOLUTIONS

- This arrangement gives the coverage of a wide range of shaft diameter, which may be standard or non-standard which is not possible in the existing gear arrangement because the manufacturing of gears for skew shafts very complex and because of standardization its only use of shafts of standard diameter.
- Proposed gear less transmission with pins can be used for very high speeds and for high loads which is comparable to the worm gear and not possible for crossed helical gears.
- This system not having any possibility of like sliding and point contact as in crossed helical gears so power loss is very low in introduced arrangement and used for high loads with proper rigidity of shafts and pins.
- The main and very interesting advantage of this proposed system is that we can changes the position of shafts during motion or during

intermittent position according to need by using given type of links at the place of pins which is not possible in any existing system till now.

- Since any dimension of any component used is not out the shafts dimensions limit, a large reduction in the size of the machines is possible .in short a large space saving should be done.
- Repairing cost on failure of any component is very low.
- Very low setup cost.
- Easy and time saving installation of setup.
- Easy manufacturing of links and pins in comparison of crossed helical and worm gear.
- Very less skill is required for setup.

6. APPLICATIONS

The featured product has its widest application as an extension for a socket wrench. Here the design makes it easy to reach fasteners in the automotive and other mechanical industries, where direct access to bolts and screws is often limited. However, the possible applications for this technology extend into numerous fields. Just think of the possibilities for power transmission in push bikes, toy sand hand-cranked equipment, or for movement transmission in store and Outdoor signage.

- Driving for all kinds four faced tower clocks. The elbow mechanism was made use of the "Big Ben Clock" having four dials on the tower of London. This clock was installed on 1630 AD and still it is functioning in good condition.
- The mechanism is invariable used for multiple spindle drilling operation called the gang drilling.
- Used for angular drilling between 0 to 90 degree position.
- Lubrication pump for C.N.C. lathe machines.
- The mechanism is very useful for a reaching a drive at a clumsy location.
- Air blower for electronic and computer machine.
- The mechanism has found a very usefully use in electronic and computer technology for multiple.
- The elbow mechanism is used for movement of periscope in submarines.

7. RESULTS

The final design thus obtained is capable of transmitting torque and power at varied angles depending on the angular limitation of the hooks joint. With further research and advanced analysis in the design wide-ranging applications of the drive can be discovered.

The model works correctly as per the design. With the help of this system, we can efficiently reduce the cost in power transmission and further advancement in this technology can be made.

There is clear in design and Fabrication of our project is safe at 140rpm to 260rpm for gearless transmission system.

8. CONCLUSION

During working on experimental setup and after a long discussion it is observed that proposed arrangement used for any set of diameters with any profile of shafts for skew shafts of any angle but the shaft's must be having the rotational motion about his own axis, transmission of motion is very smooth and desirable and used only for the equal R.P.M. of driving shaft and driven shaft by employing links or given type of links for appropriate joints for revolute pair.

Some successful mechanical devices function smoothly however poor fly they are made while other does this only by virtue of an accurate construction & fitting of their moving parts.

This projects which looks very simple & easy to construct was actually very difficult to conceive & imagine without seeing an actual one in practice. Motions demands to be studied first & we have done that very thing. We find that while acceptable analysis for existing mechanism can often be Made quite easily we cannot without insight & imagination make effective synthesis of new mechanism hence we are mould to present this our project gear less transmission at 90 degree (El-bow mechanism) which we have managed to successfully device after long & hard input in conceiving its working principle.

REFERENCES

[1] Prof. A. Kumar and S. Das, "An arrangement for power transmission between co-axial shafts of different diameter", International Journal of Engineering Research and Technology (IJERT), ISSN: 2278-0181, Volume 2, Issue 2, March 2013, Page .no: 338-347.

[2] Prof. B. Naveen Bardiya, T. karthik, L Bhaskara Rao "Analysis and Simulation of Gearless Transmission Mechanism", International Journal Of Core Engineering & Management (IJCEM) ,Volume 1, Issue 6, September 2014, Page.no: 136-142.

[3] Prof. Mahantesh Tanodi, "Gearless power transmission-offset parallel shaft coupling", International Journal of engineering Research and Technology (IJERT), volume 3, Issue 3, March 2014, Page.no.129-132.

[4]R.S. Khurmi and J.K Gupta, "Theory of machines", S. Chand publications, Hyderabad, IInd edition, 2008, Page.no: 569-589.

[5] <https://www.youtube.com/watch?v=> School of Mechanical and Building Sciences.

[6] Book s. s. rattan Mc Graw Hill Education (India) private limited, New Delhi.

[7] PSG Design data book by Dr. P. Mahadevan.

