

REVIEW OF DRONE AS FIRE EXTINGUISHER

Prof. Shailesh Birthariya ¹, Mr. Sayyam **Bhusari** ², Ms. Nikita Shingane ³, Ms Pratiksha Ghuguskar ⁴,
Ms.Ruchika Dhande⁵

^{1,2,3,4,5} Suryodaya college of Engg. And Tech., Nagpur University, India.

ABSTRACT: The research work on this paper aims to develop an unmanned aerial vehicle equipped with modern technologies various civil military applications. It is an automatic system. The shrinking size and increasing capabilities of microelectronic devices in recent years has opened up the doors to more capable autopilot and pushed for more real time UAVs applications. The Unmanned Aerial Vehicle (UAV) market is to grow dramatically by 2020, as military, civil and commercial applications continue to develop. Potential changes in air traffic management include the creation of an information It defines a UAV to be "An aircraft which is management system to exchange information among Air Traffic Management users and providers, the introduction of navigation, and the development of alternative separation procedures. The impact of each scenario on the future air traffic and surveillance is summarized, and associated issues identified. The paper concludes by describing the need for a UAV roadmap to the future. This paper aims to provide a simple and low-cost solution of an autonomous aerial surveyor which can do aerial surveillance, recognize and track various objects, able in making simple 3d map.

I. INTRODUCTION

Currently, there is a lack of unmanned aerial vehicles that are being used with the purpose of extinguish a fire or help prevent one. An unmanned aerial vehicle (UAV) is an aircraft without a human pilot on board. Its flight can be controlled autonomously by computers in the vehicle, or by remote control under the direct command of a human. In the United States and the rest of the world, most of the UAVs in existence are being used for the defence purpose. Fires that occur in homes and nonresidential buildings as well as fires in wild lands cause plenty of health issues; including death to humans and animals, in addition to great economic losses in structures, equipment and vegetation. Furthermore, the first response teams, such as firefighters, are exposing their lives to great risks in order to extinguish a fire. In addition to those huge problems, there is another one that does not cause so many struggles, but it does have a negative effect when a fire occurs. One of the most popular ways to extinguish fires is to spray water in the area affected by the flames. The water can be delivered via hose using a pressurized fire hydrant, fire sprinkler system, pumped from water sources, such as lakes, rivers or tanker trucks, or dropped from aircrafts in the case of wild land fires.

II. BLOCK DIAGRAM:

Transmitter:

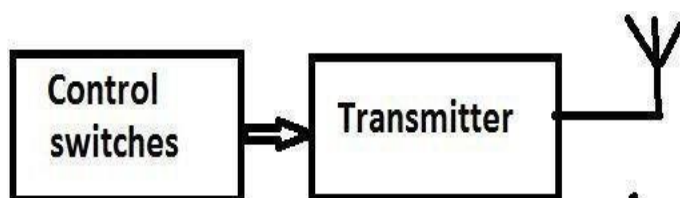

Receiver:

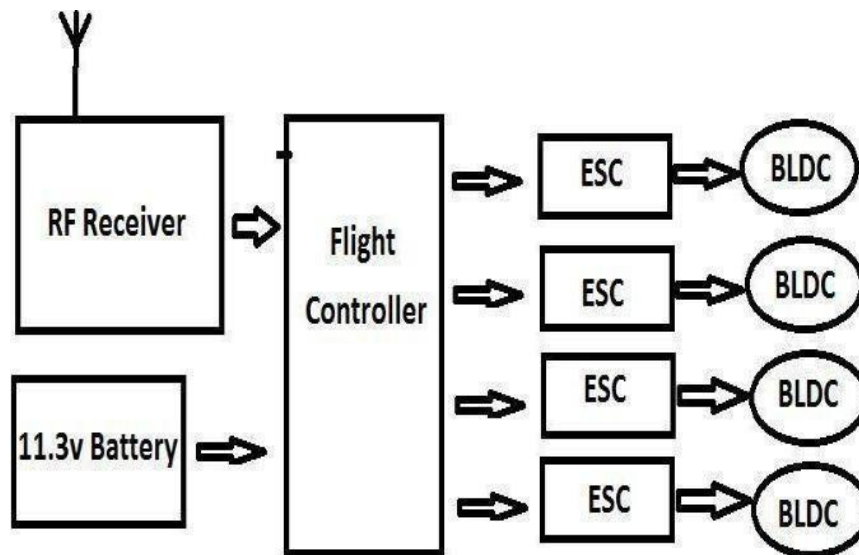

III. HARDWARE

1) Electronic Speed Controller:

An electronic speed control or ESC is an electronic circuit with the purpose to vary an electric motor's speed, its direction and possibly also to act as a dynamic brake. ESCs are often used on electrically powered radio controlled models, with the variety most often used for brushless motors.

2) Propeller

Propeller is a type of fan that transmits power by converting rotational motion into thrust. A pressure difference is produced between the forward and rear surfaces of the airfoil-shaped blade, and a fluid (such as air or water) is accelerated behind the blade.

3) Brushless DC Motor:

In order to make the operation more reliable, more efficient, and less noisy the recent trend has been to use brushless D.C motors. They are also lighter compared to brushed motors with the same power output. Additional sensors and electronics control the inverter output amplitude and waveform (and therefore percent electronically commutated motors (ECMs, EC motors) are synchronous motors that are powered by a DC electric source via an integrated inverter/ switching power supply, which produces an AC electric signal to drive the motor.

4) Battery:

An electric battery is a device consisting of two or more electrochemical cells that convert stored chemical energy into electrical energy. Each cell has a positive terminal, or cathode, and a negative terminal, or anode. The terminal marked positive is at a higher electrical potential energy than is the terminal marked negative. The terminal marked positive is the source of electrons that when connected to an external circuit will flow and deliver energy to an external device. When a battery is connected to an external circuit, Electrolytes are able to move as ions within, allowing the chemical reactions to be completed at the separate terminals and so deliver energy to the external circuit. It is the movement of those ions within the battery which allows current to flow out of the battery to perform work. Although the term battery technically means a device with multiple cells, single cells are also popularly called batteries.

5) Distribution Board :

A distribution board (also known as panel board or breaker panel) is a component of an electricity supply system which divides an electrical power feed into subsidiary circuits, while providing a protective fuse or circuit breaker for each circuit in a common enclosure. Normally, a main switch, and in recent boards, one or more residual-current devices (RCD) or residual current breakers with overcurrent protection (RCBO), are also incorporated.

6) Flight Controller :

The most important component of a multi rotor is its flight controller board. Flight control board has IMU sensors with a microcontroller to perform control task. Now what does it control A UAV needs to be stable on 3 axis i.e. pitch, roll and yaw axis so it can hover in midair. The IMU sensors sense the orientation of the aircraft and send the data to micro-controller, microcontroller processes the raw data to estimate the angles and provides error compensation to bring back aircraft to its initial position. And it does this with amazing speed and accuracy that's why we need a controller for UAVs. UAVs can run both on AVR as well as Arduino based systems.

7) 6 Channel Transmitter and Receiver:

The communication between the drone and its user is completely dependent on the transceiver. A corresponding receiver will be connected to the flight controller. The communication between the receiver and the RF transceiver is initiated by the transmitter section. The device uses ISM band spectrum (2.4 GHz) for communication. 2.4 GHz transmitter - receiver pair uses spread spectrum technique which makes it resistant to interference and gives glitch free operation. Each channel allows one individual thing on the drone to be controlled. For example, one channel for throttle, one channel for turning right and left, one channel for pitching forward and backward, one for rolling left and right.

IV. SOFTWARE :

1) FlytBase:

FlytBase is an enterprise drone automation platform which provides drone agnostic software solutions to deploy fully automated & cloud-connected commercial drones at scale. But here we are using this software just for configuring the mode of transmitter remote.

2) T6 Config:

T6 Config is the computer software which is used to program the 6 channel transmitter. By using this software we can change the controls of transmitter and based on that the motors are connected with receiver.

II. APPLICATIONS OF DRONE:

- 1) Drone are sent to fire locations as scouts, using cameras with thermal imaging technology to help first responders in their rescue efforts. It can be equipped with thermal cameras to see in the low light-dark conditions, detect irregularities on various infrastructure.
- 2) For instance, drones have been used for other applications in order to assist sudden cardiac arrests, an ambulance drone carrying a defibrillators and instructions of different first aid procedures is now in use.
- 3) Taking advantage of the drone accessibility it can be used for difficult tasks such as military and rescue missions, putting the drone to this use allows the special teams eliminate the risk of endangering human lives in these operations.
- 4) Large terrains of land and the animals that habit it can be monitored with the use of a drone so we can study and observe how the climate affects the area and its habitants.

- 5) Drones allow firefighters to quickly and effectively scout out dangerous fires, observe and monitor a large blaze and the surrounding area and more.

III. ADVANTAGES OF DRONES:

- 1) Doesn't require a qualified pilot.
- 2) Can enter any environments.
- 3) Can stay in the air for up to 30 hours.
- 4) Can be programmed to complete the mission autonomously.

IV. DISADVANTAGES OF DRONES:

- 1) Costly compared to manned vehicles.
- 2) Limited abilities.

V. FUTURE WORK:

For larger fires, it's possible that multiple drones would need to operate together, share data, respond collectively to stimuli, avoid obstacles and other dangers, and make instant decisions. Last week, a group of European researchers published research in the Science Robotics journal that demonstrated that large flocks of autonomous drones could seamlessly navigate in confined space. The research, highlighted here, demonstrated that aerial outdoor systems could exhibit flocking behaviors, similar to birds, that avoid collisions with other drones and objects without needing a central control. While the researchers didn't state this, one such application of this technology would include firefighting drones, among other use cases.

VI. CONCLUSION

To ensure operational safety, technological innovations must enable a UAS's operator to detect other aircraft to avoid midair collisions within the current and next generation air traffic control systems. The lack of standard training procedures requires regulatory attention to guarantee operators are competent and international regulations must be uniform to encourage UAS expansion.

To guarantee the security of unmanned aerial systems, exploitable weaknesses in civilian GPS technology and operational frequencies must be eliminated through the introduction of new or existing technologies in the most cost-effective manner.

VII. REFERENCES

- Nimal, R.J.G.R., Hussain, J.H., Effect of deep cryogenic treatment on EN24 steel, International Journal of Pure and Applied Mathematics, V-116, I-17 Special Issue, PP-113-116, 2017
- Parameswari, D., Khanaa, V., Deploying lamport clocks and linked lists, International Journal of Pharmacy and Technology, V-8, I-3, PP-17039-17044, 2016