

Design and Implementation of Multi-Purpose Luggage Bags

Rohit Tripathi

Department Of Electronics and Communication Engineering

Galgotias University, Yamuna Expressway,

Greater Noida, Uttar Pradesh

E-mail id - rohit.tripathi@galgotiasuniversity.edu.in

ABSTRACT: *This research outlines the creation and innovation of multipurpose luggage bags. This shows the biometric lock, the GPS tracker (Global Positioning System), the built-in emergency power bank, and the luggage bag's kick scooter. The study is planned and designed to ensure that travellers are comfortable when traveling or on any occasion that uses luggage bags. Besides offering comfort to passengers, the system also provides the protection of baggage via biometrics. The fingerprint scanner was used to enter and open the luggage bag, while the GPS device was used to monitor the luggage bag that has a built-in power bank that makes the luggage bag a gadget charging station. The luggage bag also contains a kick scooter attached to the luggage bag for easy and convenient carrying of the luggage. The system was introduced and tested at the local bus terminal. The results of the study showed a positive affirmation of its versatility, operability, aesthetics and protection group, highlighting the need to innovate and duplicate luggage bags.*

KEYWORDS: *Design and Implementation, Fingerprint Scanner, GPS (Global Positioning System, Power Bank, Luggage Bag, Solenoid Lock.*

INTRODUCTION

Traveling is very common nowadays. Travel agencies and airline companies make travel easier and cheaper for everyone. Tourism is one of the reasons for travel. People love to visit new places, to meet new people, to learn new things and to experience different cultures. Some describe travel as a measure of relief from a world full of anxieties. However, there are also business-related trips to see a relative or to see an old friend. So travel is becoming more and more common today, and millennials are one of the frequent travellers. According to the World Tourism Organization's Global Report on the Power of Youth Travel, most of today's young travellers come from the generational group of millennials born between the early 1980s and the 2000s. Price also believes that millennial travellers are relentless explorers hungry for information and prefer to travel to learn something new. O'Kelly also said that millennials are more interested in travel than the older generation. Problems faced while traveling are unavoidable. There's missing luggage, the need to recharge depleted battery devices, discomfort in carrying heavy luggage, theft and the like [1]. Most travellers reported losing their luggage [2] when they arrived, not to mention the fear of losing anything important inside. Missing luggage is very frustrating. It could have ruined the whole ride. Today's traveller wants to stay connected while on a trip. They are very dependent on technology. They make travel and communications go hand in hand. According to Shall Cross, aside from using social media to schedule their travels, millennials have an almost endless supply of smartphone apps at their fingertips while exploring everything from language translation apps to maps, meet-ups / hook-ups, ride-sharing, bike-renting, photo-enhancing and, of course, travel bookings. Nonetheless, none of these applications are useful when your mobile is out of juice. On the other hand, heavy luggage requires extra effort, instead of maximizing the time after reaching the destination, rest is the first thing a traveller wanted to do because of the exhausted feeling of carrying or dragging their luggage from the terminal to the terminal. Traveling could be adventurous. Packing light and choosing the right luggage to suit all the necessary things is the measure of a good Steve traveller. It also means free hassle. Everybody wants to travel light to a feasible degree. Carrying heavy luggage is stressful and characteristic of a typical tourist. Choosing the right bags is an integral part of flying. The role of bags [3] cannot be underestimated, it is very critical. The present study is therefore being undertaken to design and implement luggage that could meet the needs of travellers today. This luggage is a multipurpose luggage that features a built-in system that ensures security of belongings and provides convenience to the traveller. The study also assessed the traveller's insights into the features embedded in the luggage [4].

THEORETICAL CONSIDERATIONS

Problems such as lost or stolen luggage, empty battery devices, and the inconvenience of carrying heavy bags considered to be input. Input is a smooth travel experience with an integrated GPS, finger print scanner [5], and built-in battery charger installed in a luggage bag with a scooter. This study was based on several related concepts drawn from a number of relevant theories and principles. The days are gone when your luggage has served one function: to get stud from point A to point B, ideally unscathed and with bonus points if not wrinkled. PR Newswire argued that technology and design match the next generation of travel luggage. The Style section of Esquire Magazine also published a photo of Smart Carrier, which states, "The next generation of roller-carriers doesn't just transport your products, and some can even charge your phone." Barnwell believes that luggage is gradually becoming smarter, and options for wired suitcases and related accessories from start-ups to the market. Intelligent luggage will soon interact with the owner on one side and the carriers carrying it on the other [6].

METHODOLOGY

Travellers sometimes find it difficult to travel with a heavy luggage bag, but sometimes it is not a matter of having a heavy luggage bag, the real issue is the safety and security of their products. Figure 1 displays the block diagram of the multipurpose bag [7]. The battery in the diagram is a Lithium-ion rechargeable battery that supplies power to some of the Luggage Baggage components and also generates power for the Power Bank Circuit, then directly to the USB Charging Port; this allows it an emergency power source for depleted mobile phones. The lithium-ion battery is also connected to the Arduino and the Solenoid batteries. The Arduino acts as the main brain of the biometric lock, the fingerprint sensor and the solenoid lock. The Arduino supplies the fingerprint sensor and triggers the solenoid control circuit, which also activates the solenoid when the fingerprint sensor detects the correct fingerprint. The solenoid needs a higher voltage

The GPS module is the tracker of the bag when the bag is lost or stolen; it is connected directly to the battery charger because the GPS module has its own power supply / battery. The Luggage Bag has its own battery charger; the DC output is connected directly to the battery while the AC input is connected to the AC Adapter outside the Luggage Bag [3], so that the user can recharge the battery for free.

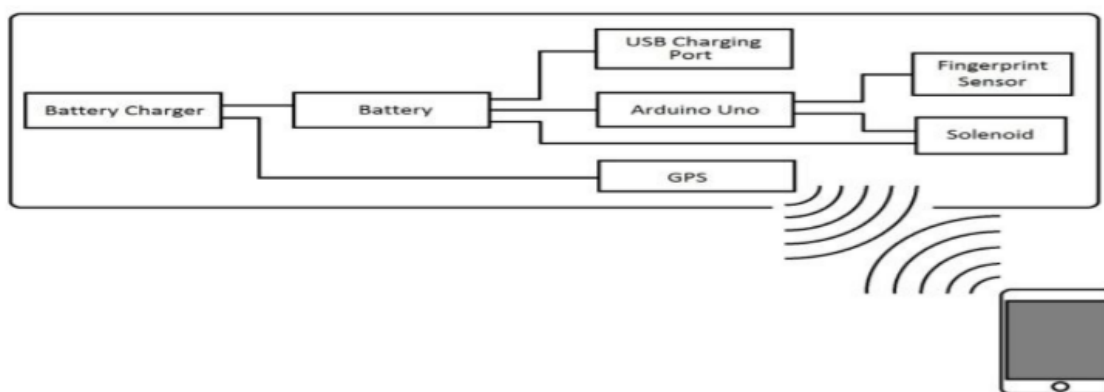

Figure.1: Block diagram of the 4in 1 luggage bag

Figure 2 shows the connections of the main component of the multipurpose luggage bag; the fingerprint sensor, the solenoid and the solenoid driver controlling the solenoid through the Arduino. The battery is then connected to the battery charger inside the luggage bag that is connected to the AC adapter outside the luggage bag. The battery is also connected to the 5v power bank circuit, enough to charge mobile phones. Switch is used to give the owner the option to turn on the power when opening or using the built-in power bank of the luggage bag. White, green, blue and red LEDs are indicators for the biometric lock. The white LED is used to indicate an attempt by users to erase or change the current registered fingerprint ID. The green LED indicates the functionality of the solenoid, whether it is opened or not. The blue LED is used to show the default program that is the "recognize" program, which indicates that the fingerprint sensor is able to identify the registered fingerprint ID. The red LED then shows the "unregistered fingerprint" program, which means that the fingerprint entered is unregistered. The two-track switch helps the owner to adjust and

restore the system to normal. Switch1 is to change the current registered fingerprint after it has been changed; press the second switch (Switch2) to reset the system to normal.

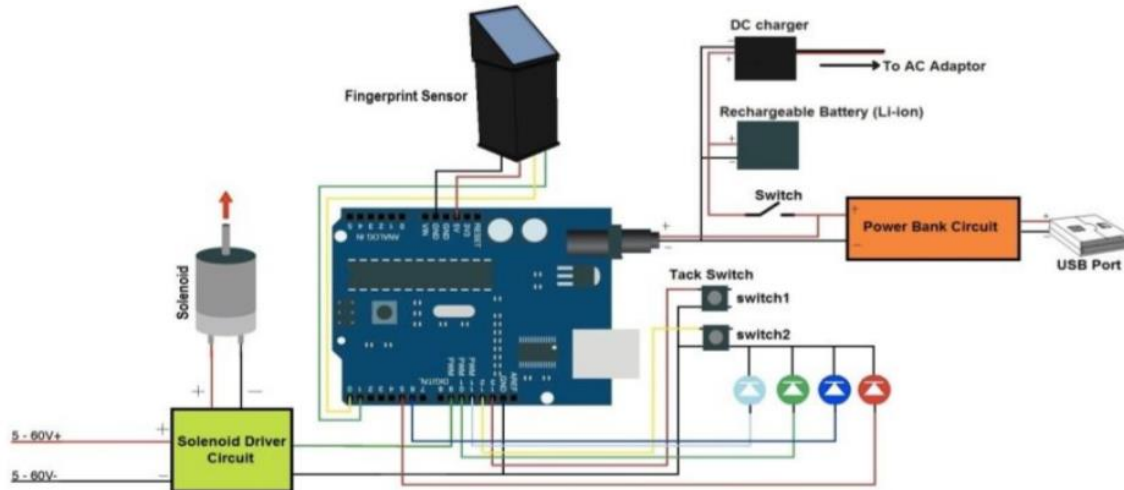

Figure.2: Components and Circuit Layout

Figure 3 shows the process flow of the multipurpose luggage bag, the luggage bag has a power switch that controls some of the luggage bag components. If the power switch is ON, the Arduino Uno and the 5v power bank are triggered. When the Arduino Uno is activated, the fingerprint and two tack switches are also activated. The Fingerprint Sensor / Module is set to the default program that is ready to recognize the registered fingerprint, if the typed fingerprint does not match the current registered fingerprint, it will automatically return to the default program called "Identification."

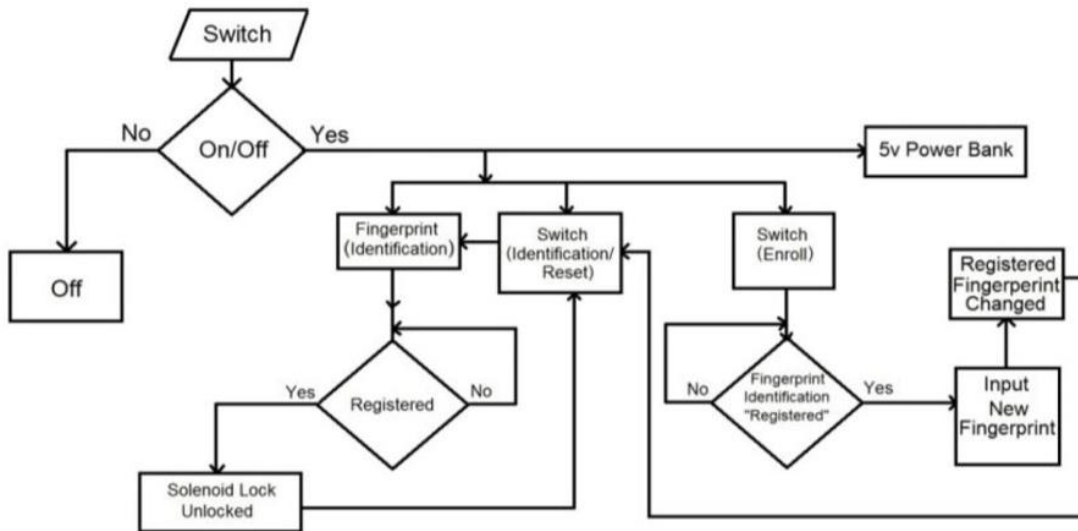

Figure.3: Biometric Lock Process Flow

Nevertheless, if the fingerprint sensor recognizes the fingerprint [8], the solenoid lock will be activated and opened. To close the solenoid lock, the system returns to normal by pressing the Identification / Reset button. The other button, the Enroll button, allows the owner to change the current registered fingerprint. But then, in order to enroll a new fingerprint, it requires the latest recorded fingerprint. And to reset the program to default or lock the solenoid lock, press the reset switch1 and return the solenoid lock from its current state to its default state. Figure 4 displays the operation flow of the Global Positioning System (GPS) [9]. When the GPS module is switched on, sending a text message to the GPS module number will enable the GPS module to stand by. After a text message, the GPS will say, "Start OK!" This means that the GPS module is ready to receive a call from the courier. When calling the GPS module number, the call ends automatically after the

call ends the GPS module number, and then sends a message containing the contact information (longitude, latitude and Google Map link) [10].

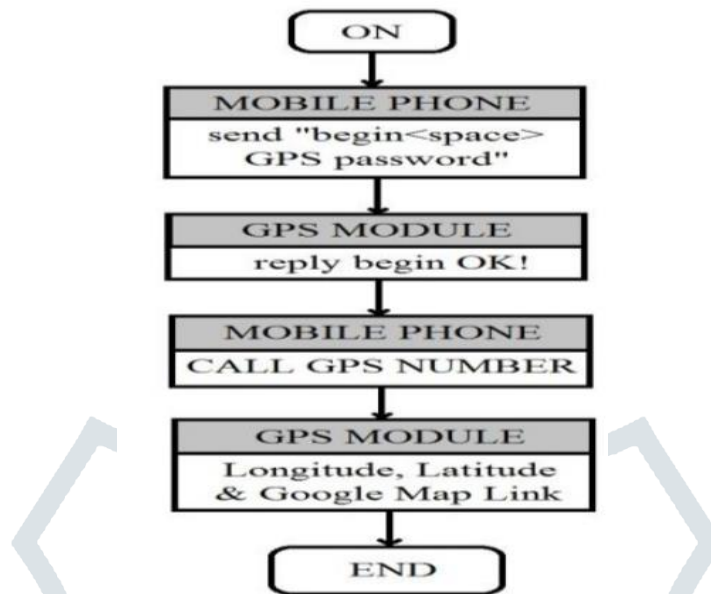

Figure.4: Global Positioning System (GPS) Process Flow

Figure 5 shows the project's digital design diagram, the first figure from the right shows the power switch, followed by the AC adapter, which acts as a bridge from the outlet to the battery charger, followed by the last picture that shows the fingerprint sensor, recognizes and enrolls the device, the USB port, and the solenoid lock.

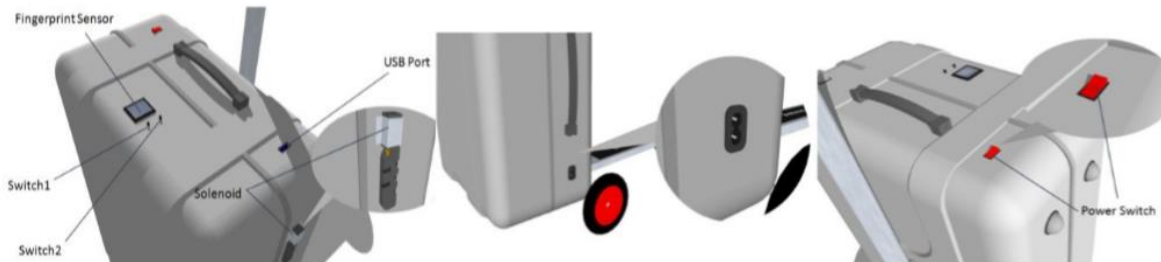

Figure.5: Graphical Design of the Project

The project will be tested to see if it will provide travellers with quality and comfort. As far as Functionality is concerned, its function is not only to provide comfort, but also to ensure the safety and security of products within. As far as Aesthetic is concerned, the devices and components of the luggage bag are well covered and placed inside the luggage bag, and the scooter attached to the luggage bag is made available enough to carry it around. As far as the operability of this project is concerned, the fingerprint scanner / sensor has been engineered as easy to use and as user-friendly as possible, it operates one to two days max with a fully charged battery because the bag has a power switch so that the user can turn on or off the device and only needs to be switched on when the user uses the USB port to recharge the device. The scooter is also well used, there is no sharp object that can unintentionally damage the user. Multipurpose bags are analysed using quantitative data using interview, observation or analysis of the subject and data collected from a range of selected respondents.

- Functionality, evaluation was carried out by observation of the functions of the equipment inside the luggage. Whether the instructions given by the researchers are true and correct or whether the devices are working.

- Operability, assessment of multipurpose luggage bags by providing reliable operating instructions for easy use by the user. Whether these devices are safe and easy to operate.
- Aesthetics, evaluation of the physical outlook of the project within the external and internal outlook. The luggage bag's whole outlook; inside and outside.
- Type in anything that you want. Then click Quill It on the right to paraphrase your input.

RESULTS

The results and findings of the research are based on the proven test methodology, which highlighted the design, production and evaluation of the multipurpose Luggage Bag. It indicates the input and output elements of this project. The project is open in terms of design and purpose. The external elements are firmly anchored in the project. These tools are the Fingerprint Scanner, the Arduino board, the GPS tracker and the built-in mobile phone charging power bank. The system has been designed for safety and emergency purposes. This initiative offers extra support to those who have accompanied their children or the elderly because the scooter is connected to this unit. Engineers have successfully designed and implemented a multipurpose bag for 50 Agora Bus Terminal passengers. This innovative bag contains many features such as the Biometric Lock, the GPS Tracker, the Portable Charger and the Built-in Kick Scooter. The apps are user-friendly and work very well, the physical appearance is very presentable. Respondents were delighted and impressed at the prototype when asked to check the features found in the prototype. With regard to these issues, based on the assessment survey rating and the respondent's suggestions, some modifications and recommendations should be made to the project or prototype; that the prototype should have at least 2 ports for charging installations, a battery and a charger indicator in order to avoid overcharging the battery and, finally, that these devices should be properly installed.

CONCLUSIONS

The researchers have successfully designed and implemented a multipurpose luggage bag for the 50 Agora Bus Terminal passengers. This innovative luggage bag includes four features, such as the Biometric Lock, the GPS Tracker, the Portable Charger and the Built-in Kick Scooter. The apps are user-friendly and function very well, the physical appearance is very presentable. Respondents were satisfied and amazed at the prototype when asked to evaluate the features embedded in it.

REFERENCES

- [1] S. Han and H. S. Koo, "Anti-theft travel bag design: Advantage, interest, and satisfaction," *Int. J. Fash. Des. Technol. Educ.*, 2014.
- [2] F. A. Kondori and S. Yousefi, "Smart baggage in aviation," in *Proceedings - 2011 IEEE International Conferences on Internet of Things and Cyber, Physical and Social Computing, iThings/CPSCOM 2011*, 2011.
- [3] A. Colley, M. Pakanen, S. Koskinen, K. Mikkonen, and J. Häkkinen, "Smart handbag as a wearable public display - Exploring concepts and user perceptions," in *ACM International Conference Proceeding Series*, 2016.
- [4] A. L. Abhang, C. Lotan Mahale, V. R. Desai, and P. Biswas, "IJSRST1845334 | Smart Bag," *2018 IJSRST* /, 2018.
- [5] J. Sapes and F. Solsona, "Fingerscanner: Embedding a fingerprint scanner in a raspberry pi," *Sensors (Switzerland)*, 2016.
- [6] M. S. Rosdi and N. Ahmad, "Smart handbag system with location tracking," *ARPJ. Eng. Appl. Sci.*, 2016.
- [7] M. Shweta, P. Tanvi, S. Poonam, and M. Nilashree, "Multipurpose Smart Bag," in *Procedia Computer Science*, 2016.
- [8] C. Jiang, Y. Zhao, W. Xu, and X. Meng, "Research of fingerprint recognition," in *8th IEEE International Symposium on Dependable, Autonomic and Secure Computing, DASC 2009*, 2009.
- [9] J. L. Awange, "The global positioning system," in *Environmental Science and Engineering (Subseries: Environmental Science)*, 2012.
- [10] G. Xu, *GPS: Theory, algorithms and applications*. 2007.