

# A Review on Brake Assist System

Puneet Panchal, Department Of Electrical Engineering  
Galgotias University, Yamuna Expressway Greater Noida, Uttar Pradesh  
E-mail id - puneet.panchal@Galgotiasuniversity.edu.in

**ABSTRACT:** Brake assistance is one of the protection features used in the new vehicles. It is one of the systems that is involved, helping to stop the trucks from a crash. In an emergency situation, brake assistance works when the driver pushes the brake pedal with inadequate force. In such a scenario, the car does not have enough time to lead to an accident. Brake aid in that situation this condition is decided by the machine and brake boost is increased so that the car stops at an appropriate distance. The brake assist unit is installed after no test & a substantial amount of testing has been conducted. It has been shown that the brake assist system reduces by a large margin the stopping distance. It decreases the stopping distance up to the 20%. Both the percentages of severe accident involving pedestrians as well as the rate of rear end collision are for lower for the vehicles equipped with BAS than the vehicles without BAS.

**KEY WORDS:** Brake assist system, ABS, ASR, Solenoid, Released system

## INTRODUCTION

The history of the car begins with the invention of I.C engines, but the actual invention began in 1886. The first car factory was introduced by Mercedes Benz. The car was not technically built during those days. The vehicle concept was advanced, a motor carriage that could accommodate two or more people. As time progressed, the car has become more and more technologically advanced and its ownership has become a "status" In culture, sign Earlier while purchasing a car customer think only cost & comfort, but now the people started concentrating on the safety of the car i.e. how safe the car /as the human life is more valuable than anything else. The modern day cars like Mercedes Benz, BMW, Rolls Royce, etc. are coming with a number of safety devices which try to save the human life in case of accident or an emergency. Brake assist is one of the safety system which use in recent cars. It is one of the active system which helps to save the cars from the collision. Brake assist works in an emergency situation when the driver press brake pedal with insufficient force. In such case car does not at sufficient distance which leads to accident. In that case brake assist system determines that situation and it increases brake boost so that car stop at sufficient distance. Brake assist system is installed after the no of test & great amount of research has been carried out. Brake assist system has been shows that it reduces the stopping distance by a significant margin (Fig. 1). It decreases the stopping distance up to the 20%. Both the percentages of severe accident involving pedestrians as well as the rate of rear end collision are for lower for the vehicles equipped with BAS than the vehicles without BAS. Mercedes Benz became the first company to make the Brake Assist as the standard equipment on all its models[1].

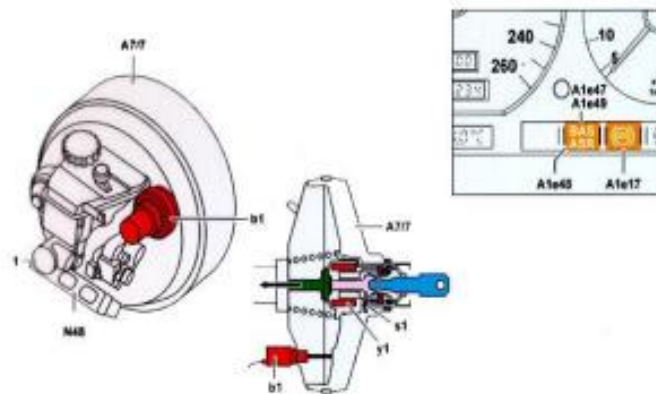

**Fig. 1: Brake Assist System**

Working modes of BAS system:

Standard modes: In this case, there is no corresponding high pedal speed braking (which requires BAS to do so). To be turned on). In its initial position, the solenoid valve in the BAS brake booster is de-energized[2].

**Increase in BAS pressure:** The BAS pressure increases with respect to the speed at which the brake pedals work and the speed of the vehicle. The control module recognizes that the BAS switching condition occurs. It actuates the BAS solenoid valve the BAS control module produces the brake booster[3].

**BAS pressure reduction:** The BAS control module receives the BAS release switch information that the BAS control module receives. Emergency braking was achieved. The BAS solenoid valve is no longer actuated and the full brake boost they're turned off[4].

**Actual working of BAS in normal mode:**

The BAS brake booster (A7/7) is continuously delivered through the vacuum intake pipe or pump vacuum pipe or diesel (Fig. 2). The same vacuum or pump vacuum prevails on both sides when the brake pedal is not controlled. In its original location, the diaphragm plate[5].

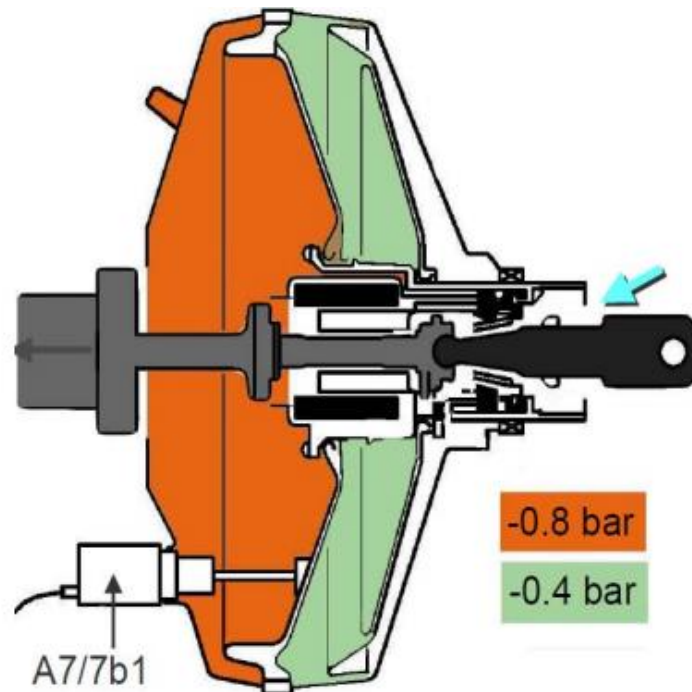

**Fig. 2: vacuum brake booster when BAS in normal mode**

When braking, external air is fed via a port to the back of the diaphragms. When braking takes place, the pressure increases. Differences exist between the booster's front and back chamber, which works in the direction of the master the cylinder raises the force exerted by the driver's foot[6].

When braking, external air is fed via a port to the back of the diaphragms. When braking takes place, the pressure increases. Differences exist between the booster's front and back chamber, which works in the direction of the master the cylinder raises the force exerted by the driver's foot[7]<sup>i</sup>.

Working of BAS during pressure increase the conditioned for switching on BAS met the BAS solenoid valve (y1) open. Atmospheric pressure acts on back of rolling diaphragm. The pressure difference between the back and front side of diaphragm causes maximum brake boost. BAS is switched on if the following conditions occur at the same time. 1. Speed > 10kmph. 2. BAS release switch is operated. 3. No actual faults are recognized. 4. Switch on threshold of pedal speed exceeds[8].

**Working of BAS during pressure decrease:**

The BAS release switch (s1) is passive-switched. The solenoid valve (y1) is turned off and the number of solenoid valves is also switched off[9]. It creates brake pressure corresponding to the position of the brake pedal. If one of the following conditions happens, BAS is turned off:

1. Unable to operate the BAS release switch
2. The speed is below 30 kmph.

3. If no signal is switched from the stop lamp after BAS has been switched on.

4. A fault is recognized that contributes to the BAS malfunction indicator lamp being actuated.

## REVIEW OF LITERATURE

There have been many papers published in the field of brake system of vehicle among all those papers a paper titled "A Review on Brake Assist System" by S. Mahajan, Jesse Joy, Akash Landge, Vrushabh Dalvi, Vishal Dabhade discussed about the brake assist system, working model of BAS systems, also explain the actual working of BAS in normal mode, discussed working of BAS when pressure increasing, pressure of BAS when pressure is decreased, explains the different types of safety systems, explain the safety device and construction of BAS[10].

## CONCLUSION

The results of automotive & mechanical engineering show us the strong development of the automotive industry. Evolutions. There is one very important factor, i.e., besides quality appearance & economy of the vehicle. Security". Safety." I have focused on "BAS" in this article, i.e. the brake assist system, which is an active safety device. Usage of the BAS has greatly helped to increase the braking performance of cars and to avoid accidents in cars. Situations of urgency. Including automobiles. After a lot of testing, Mercedes Benz utilizes these innovations, making it one. Some of the world's safest vehicles. Despite all advances, occasional incidents are still present, leading to casualties. Beeke has always been able to minimize injuries challenging task for engineers as human life is most precious of all.

## REFERENCES

- [1] A. H. Braking and E. Braking, "Analysis of Driver Behaviour in Autonomous," *Fisita 2008*, 2008.
- [2] R. Schoneburg, K.-H. Baumann, and R. Justen, "Pre-Safe - the Next Step in the Enhancement of Vehicle Safety," 2003.
- [3] T. Hirose, T. Taniguchi, T. Hatano, K. Takahashi, and N. Tanaka, "A study on the effect of brake assist systems (BAS)," *SAE Int. J. Passeng. Cars - Electron. Electr. Syst.*, 2009, doi: 10.4271/2008-01-0824.
- [4] S. Murugan, M. C. Ramaswamy, and G. Nagarajan, "The use of tyre pyrolysis oil in diesel engines," *Waste Manag.*, 2008, doi: 10.1016/j.wasman.2008.03.007.
- [5] K. Yi, Y. Cho, S. Lee, J. Lee, and N. Ryoo, "A Throttle / Brake Control Law for Vehicle Intelligent Cruise Control," *FISITA World Automot. Congr.*, 2000.
- [6] I. Choi, N. Corson, L. Peiros, E. W. Hawkes, S. Keller, and S. Follmer, "A Soft, Controllable, High Force Density Linear Brake Utilizing Layer Jamming," *IEEE Robot. Autom. Lett.*, 2018, doi: 10.1109/LRA.2017.2761938.
- [7] T. Grigoratos and G. Martini, "Brake wear particle emissions: a review," *Environ. Sci. Pollut. Res.*, 2015, doi: 10.1007/s11356-014-3696-8.
- [8] D. Chan and G. W. Stachowiak, "Review of automotive brake friction materials," 2004, doi: 10.1243/0954407041856773.
- [9] N. M. Kinkaid, O. M. O'Reilly, and P. Papadopoulos, "Automotive disc brake squeal," *Journal of Sound and Vibration*. 2003, doi: 10.1016/S0022-460X(02)01573-0.
- [10] S. Mahajan, J. Joy, A. Landge, V. Dalvi, and V. Dabhade, "A Review on Brake Assist System," vol. 4, no. 3, pp. 199–208, 2015.

- Balamurugan Shanmugam, VisalakshiPalaniswami, "Modified Partitioning Algorithm for Privacy Preservation in Microdata Publishing with Full Functional Dependencies", *Australian Journal of Basic and Applied Sciences*, 7(8): pp.316-323, July 2013
- Jaganraj L, Balamurugan S. Empirical Investigation on Certain Anonymization Strategies for Preserving Privacy of Social Network Data, *International Journal of Emerging Technology and Advanced Engineering*. 2013 Oct; 3(10):55–63

- B.Powmeya , Nikita Mary Ablett ,V.Mohanapriya,S.Balamurugan, ”An Object Oriented approach to Model the secure Health care Database systems,”In proceedings of International conference on computer , communication & signal processing(IC3 SP)in association with IETE students forum and the society of digital information and wireless communication,SDIWC,2011,pp.2-3, 2011
- Kavita Arora, Dr. Kavita, Dr. Vishal Jain. (2020). A Study On Attacks In Mobile Ad-Hoc Networks. International Journal of Advanced Science and Technology, 29(8s), 279 - 289. Retrieved from <http://sersc.org/journals/index.php/IJAST/article/view/10502>
- Kavita Arora, Kavita, Vishal Jain, Impacts of Black Hole Attack on Mobile Ad-hoc Networks, International Journal of Future Generation Communication and Networking, Vol. 13, No. 4, (2020), pp. 644–653
- Gomathy, V., Padhy, N., Samanta, D. et al. Malicious node detection using heterogeneous cluster based secure routing protocol (HCBS) in wireless adhoc sensor networks. J Ambient Intell Human Comput (2020). <https://doi.org/10.1007/s12652-020-01797-3>.

