

Time Analysis of Primary and Backup Relay

Dr.Kola Sambangi Sambaiah,

Spandanagowda N D,

Faculty of Engineering and Technology, Jain (Deemed-to-be University), Ramnagar District, Karnataka – 562112

Email Id- k.sambaiah@jainuniversity.ac.in

Malatesh Akkur

Associate Professor, Department of Electronics and Renewable Energy,

School of Sciences, B-II, Jain (Deemed to be University), JC Road, Bangalore-560027.

ABSTRACT: Power system is a wide area of research. Power's systems protections are the part within power system. Power system protection basically means to protect the equipments like generator, transformer, transmission line, motor etc. from fault. The equipments that used for protection of power system are fuses, isolator, relay, circuit breaker etc. In this research two systems are considered one is radial system and other is ring system. Both systems are calculated for fault where relay arrangement has been shown. After the fault on system, primary relay and back up relay trip setting has been done according to level of fault. In this research for radial system it is found that relay R5 is the primary relay trip in 0.10 second which is connected with the circuit breaker 5 and back up relays operate after .30 second. Similarly, for ring system it is found that relay R5 is the primary relay trip in 0.10 second which is connected with the circuit breaker 5 and back up relays operate after .30 second.

KEYWORDS: Circuit breaker (CB), Protection System, Primary Relay, Backup relay, Radial System, Ring System.

INTRODUCTION

1. What is radial system?

The system is a combination of different components like generator, buses, relay, circuit breaker etc. radial system have single path for current flow with the combination of different components. The connection of generation in series with the substations.

2. What is ring system?

The system is a combination of different components like generator, buses, relay, circuit breaker etc. In ring system the connections are in the form of loop where generation is connected with different substations through buses [1].

3. What is protection system?

There are different types of equipment used for electricity generating, transmitting and distributing. The equipment used for electricity generating, transmitting, distributing are transformer, generator, motor etc. power system protection is used to protect these types of equipments [2]. The power system protection consists of different types of protecting devices that helps in protection of equipments for the electricity generating, transmitting and distributing. The different types of protecting devices as shown in Figure 1.

4. What is Relay?

Relay exists as the component of energy systems protection which can be used for separating the faulted components in between the healthy parts of the plant. There are different types of relay which are used according to the protection of equipment [3].

5. What is primary relay?

The primary relay is the first source to protect the equipments from fault.

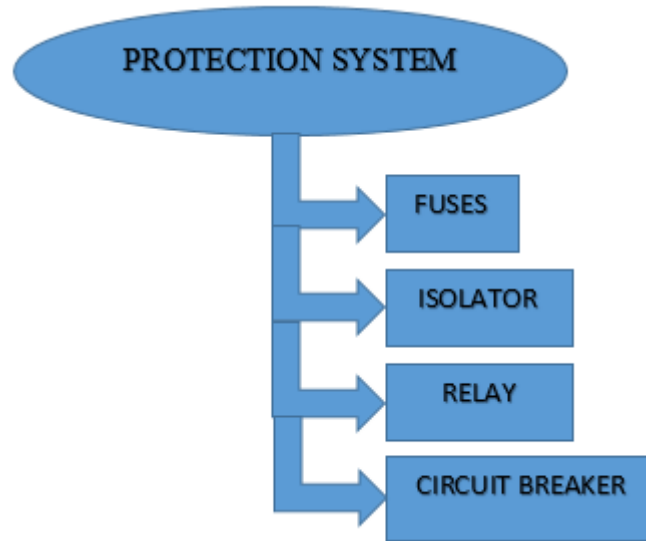

Figure 1: Equipments used for power system protection

6. What is backup relay?

Backup relay protects equipments at the time of fault and operates when first relay cannot operate. Alternate relays also called secondary relay.

Research Question

- Importance of primary and backup relay
- What is power system protection?

LITERATURE REVIEW

There are different researches related to “time analysis of first and other relays” In which the following are some description:

As in “a first and other protections algorithms grounded over voltages as well as currents measurement in HVDC’s grid” author Ku leuven et al. analyzed the protection system where a data base algorithm is used and voltage and current value detected and linear discrimination analysis (LDA) is used for analysis of protection of power plant.

Author Rynato andal gamboa et al. studied the relay communication as well as skidding series of transmission line for Taylor's university electrical distribution system (TUEDS) using electrical transient analysis software (ETAP) by selecting suitable relay and circuit breaker in their paper "System protection synchronization research for electrical power system."

Author Yiqing Liu et al. analysed the relay output back - up protective mechanisms also for entire transmission line and its linked transmission lines in their paper "design of a substation area backup protective relays for smart substation." Digital signal processor/field programmable gate array has built a prototype based on the proposed scheme and standards[4].

Author Ali raza et al. analysed a novel algorithm based on a nave bayes classifier is proposed to decide threshold level and operating time for primary and backup security in HVDC in their paper "a protection scheme for multi-terminal vsc-hvdc transmission system."[5].

METHODOLOGY

1. Design:

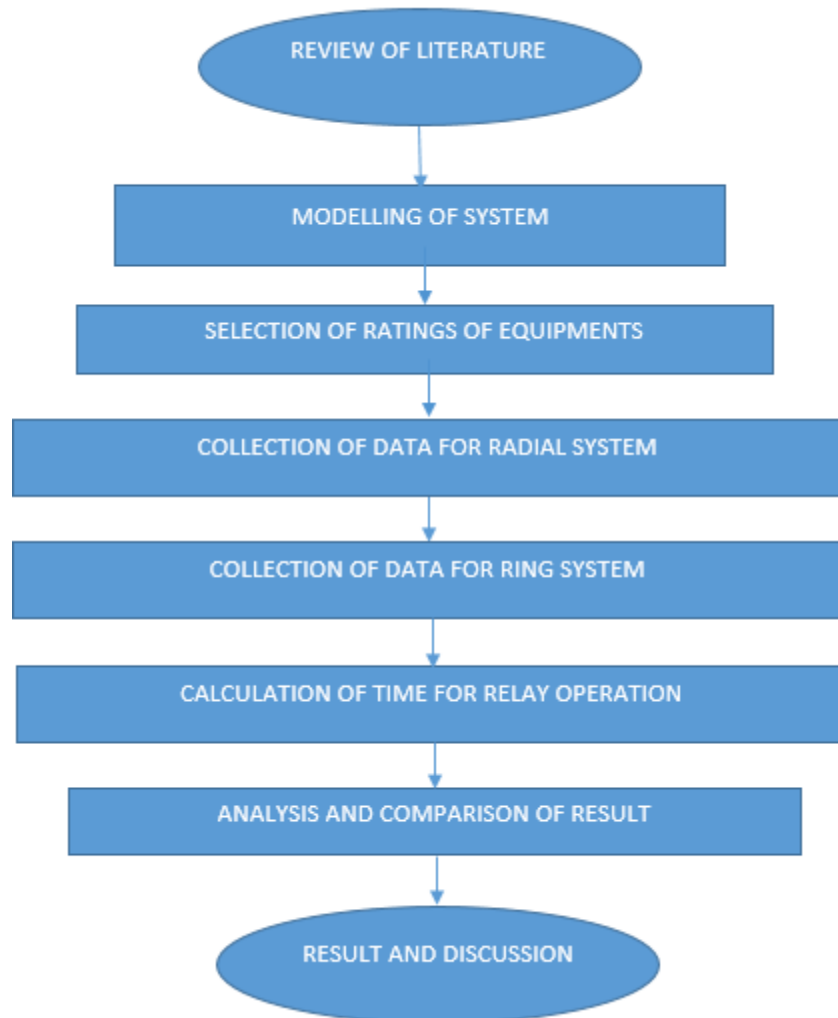

Figure 2: Methodology

The methodology of calculation and analysis of operation of relay time for radial system and ring system is shown in Figure 2.

2. Sample:

The instruments used in this research are at rated calculated value, according to the calculation of time of tripping of relay for radial system and ring system. Above which the equipment may burn. Some measuring instruments are also used for this experiment research. The data of both the systems radial system and ring system has been collected to calculate the time for relay operation according to the fault on system.

3. Instrument:

In this Research, data has been collected by selecting two systems radial system and ring system. Analysis has been done by calculation of fault current and relay time.

4. Data Collection and Analysis:

Two systems are considered for analysis of primary relay and back-up relay. The two systems are radial system and ring system, where Figure 3 shows the radial system and Figure 4 shows the ring system.

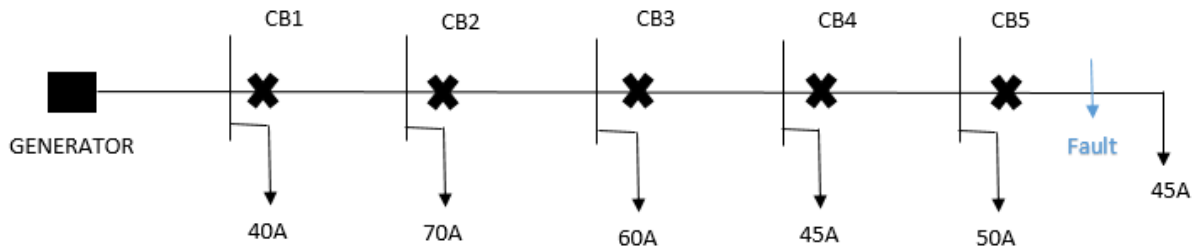

Figure 3: Radial system

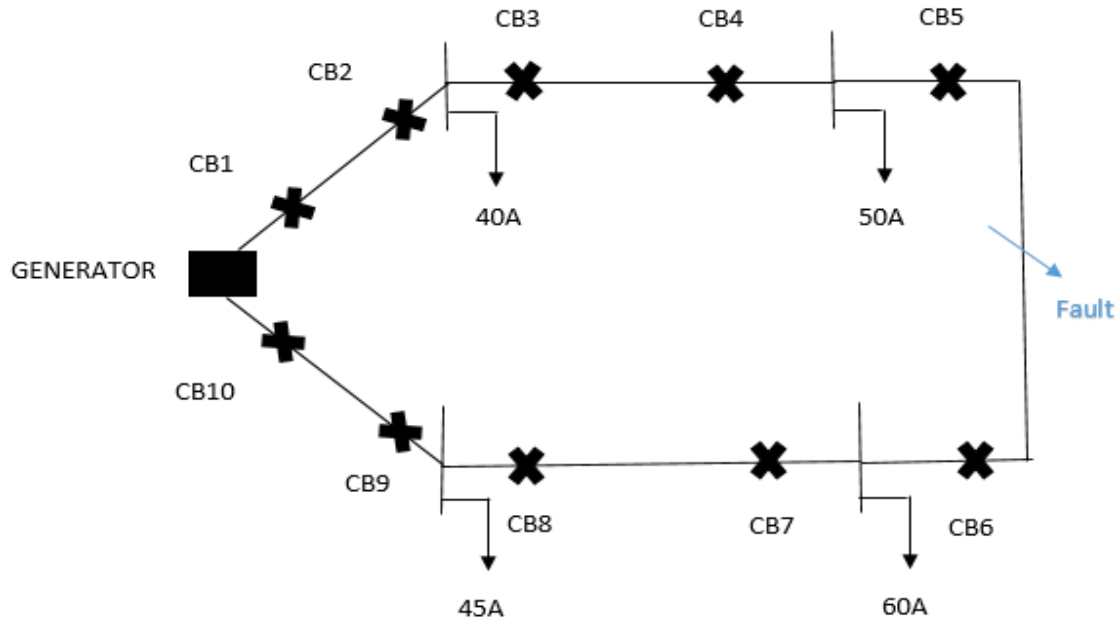

Figure 4: Ring system

For Radial system:

Time setting multiplier (TSM) = 0.020sec

Fault current = 600A

Pick up current for Relay 5 (R5) = 150A

$$\text{Plug setting multiplier (PSM)} = \frac{\text{Fault current}}{\text{Actual pick up current}} = \frac{600}{150} = 4$$

First relays' Operational timings of (R5) = 0.10sec

Secondary relays' Operational timings (R4) = TMS of Relay 5 + 5th relay's operational timings

Secondary relays' Operational timings (R4) = 0.20 + 0.10 = .30sec

Secondary relays' Operational timings (R3) = TMS of Relay 4 + 4th relay's operational timings

Secondary relays' Operational timings (R3) = 0.30 + 0.05 = .35sec

Secondary relays' Operational timings (R2) = TMS of Relay 3 + 3rd relay's operational timings

Secondary relays' Operational timings (R2) = 0.35 + 0.06 = .42sec

Secondary relays' Operational timings (R1) = TMS of Relay 2 + 2nd relay's operational timings

Secondary relays' Operational timings (R1) = 0.42 + 0.07 = 0.49sec

For Ring system:

Time setting multiplier (TSM) = 0.020sec

Fault current = 600A

Pick up current for Relay 5 (R5) = 150A

$$\text{Plug setting multiplier (PSM)} = \frac{\text{Fault current}}{\text{Actual pick up current}} = \frac{600}{150} = 4$$

First relays' Operational timings (R5) = 0.10sec

Secondary relays' Operational timings (R3) = TMS of Relay 5 + 5th relay's operational timings

Secondary relays' Operational timings (R3) = 0.20 + 0.10 = 0.30sec

Secondary relays' Operational timings (R1) = TMS of Relay 3 + 3rd relay's operational timings

Secondary relays' Operational timings (R1) = 0.30 + 0.05 = 0.35sec

Secondary relays' Operational timings (R7) = TMS of Relay 1 + 1st relay's operational timings

Secondary relays' Operational timings (R7) = 0.35 + 0.06 = 0.42sec

Secondary relays' Operational timings (R9) = TMS of Relay 7 + 7th relay's operational timings

Secondary relays' Operational timings (R9) = 0.42 + 0.07 = 0.49sec

Secondary relays' Operational timings (R10) = TMS of Relay 9 + 9th relay's operational timings

Secondary relays' Operational timings (R10) = 0.49 + 0.08 = 0.57sec

RESULTS & DISCUSSIONS

The calculation and analysis of relay for radial system and ring system has been done successfully. Where different data of radial system and ring system has been selected and relays are connected according to calculation and setting. According to the level fault, relay will operate for both radial system and ring systems. For relay pick up current is 150A and Maximum fault current is 600A. After the calculation of different factors for radial system and ring system, it is analyzed that for radial system R5 relay which is connected with CB5 is the primary relay and R1, R2, R3, R4 are the backup relays. For ring system R5 relay which is connected with CB5 is the primary relay and R3, R1, R7, R9, R10 are the backup relays.

CONCLUSION

This research analyzed by designing system and calculation approaches. From the above research, it is found that the calculation of relay has been done for radial system and ring system. Result for calculation of relay for both the systems are calculated and analyzed that the best protection of equipments from fault. If the relay works at selected time, then as the fault happen relay operate and protect the different equipments from fault. The primary and backup relay for radial system and ring system has been selected according to time calculation. For future scope the relay setting for other systems can be analyzed and can find different techniques to protect the large equipments like generator, motor, transformer etc. from fault that is beneficial for smooth working of power system.

REFERENCES

- [1] S. G. A. Perez, T. S. Sidhu, and M. S. Sachdev, "Modeling relays for power system protection studies," *Electrical Engineering*, 2006.
- [2] M. A. Zamani, T. S. Sidhu, and A. Yazdani, "A protection strategy and microprocessor-based relay for low-voltage microgrids," *IEEE Transactions on Power Delivery*, 2011, doi: 10.1109/TPWRD.2011.2120628.
- [3] M. H. Hussain, S. R. A. Rahim, and I. Musirin, "Optimal overcurrent relay coordination: A review," 2013, doi: 10.1016/j.proeng.2013.02.043.
- [4] Y. Liu, H. Gao, W. Gao, and F. Peng, "Development of a Substation-Area Backup Protective Relay for Smart Substation," *IEEE Transactions on Smart Grid*, 2017, doi: 10.1109/TSG.2016.2527687.
- [5] A. Raza, "a protection scheme for multi-terminal vsc-hvdc transmission system," 2017.