

# Fabrication Of Solar Powered Bird Scarer

<sup>1</sup>Nagaraj Kulkarni, <sup>2</sup>Parashuram, <sup>3</sup>PunithH J, <sup>4</sup>Rahul J and <sup>5</sup>Avinash S

<sup>1, 2, 3, 4</sup> Students and <sup>5</sup> Assistant Professor

School of Mechanical Engineering, REVA University, Bengaluru, India

**Abstract:** All around the world, domestic birds are a major threat in the field of agriculture causing damage to economic field crops, storage houses and also dirtying human life areas. In order to distract these birds away, many traditional methods such as Scarecrow models, Hawk kites, Colored lights, Lasers, Flashes, Chemicals and firing gun etc are used which nowadays do not seem very effective. In this project an effective bird deterrent technique i.e. Solar Powered Bird Scarer has been developed. For this project the conversion of the solar energy is done by the solar panel and this energy is made use of bird scarer. Solar electricity is the technology of converting sunlight directly in to electricity. It is based on photo-voltaic or solar modules, which are very reliable and do not require any fuel or servicing. Solar electric systems are suitable for plenty of sun and are ideal when there is no main electricity. Wastage of crops due to rodents, birds and animal is increasing at a faster rate. Our project aims to control wastage of crops and food grains due to birds. The main focus of agricultural engineering is to apply various engineering and technological principles in crop production to maximize production and to minimize wastage.

## 1. INTRODUCTION

Birds, known to play an important role in pollination, putting a check on pesky insects and rodents, could also be causing drastic decrease in crop yields by destroying them, according to a report, which calls it as an emerging concern in Indian agriculture. The avian species inflict losses in agriculture by damaging crops during sowing, seedling and ripening stages, leading to economic losses to the farming community, shows the intermenstrual report of the Committee on Doubling Farmer's Income (DFI) - Volume X titled "Risk Management in Agriculture", released by the Ministry of Agriculture. "Birds are known to cause considerable economic damage to variety of crops during vulnerable stages in different agro-ecological regions of the country. The extent of bird damage to any crop depends on several factors like concentration of local bird population, total area under the crop, cropping pattern habitat of the area, season and physiological status of the birds," stated the report. It identified 63 bird species of birds, 1,364, from 19 families that caused damage to several crops. A whopping 52 bird species attacked cereals, pulses got attacked by 14 bird species, while oilseeds faced damage risk by 15 species, and fruits by 23 species. They also caused damage to the crops of smaller grains such as pearl millet and sorghum as well as maize. Of these, the Grey Partridge, Blue Rock Pigeon and House Sparrow were found to inflict most damage to crops. Other species include the Rose ringed parakeet, weavers, munias and doves that manage to nest in close proximity to agricultural fields. The report, however, also identified 46 bird species as beneficial for agriculture. They help destroy insects feasting on crops and also consume rodents. Such beneficial birds need to be encouraged and conserved; the report suggested. Moreover, bird damage was found to be more in isolated, early or late maturing fields, varied between regions, seasons, number of species, their density, concentration of migrants and their food habits. Protecting the production system and effective management of vertebrate pests is important to realize targeted yields. While traditional management techniques for predatory birds include erecting a machan amidst crop fields, pitcher-effigy (scare crows), drum beating; habitat manipulation, block plantation, reflective ribbon for bird scaring, reflective paper plate, bird resistant hybrids, could be some of the eco-friendly management methods.

## EARLIER METHODS OF BIRD SCARING

### i. SCARECROW

One of the oldest designs of bird scarer is the scarecrow which is in the shape of a human figure. The scarecrow idea has been built upon numerous times, and not all visual scare devices are shaped like humans. The "Flash man Birdscarer, "Iridescent tape," Terror Eyes balloons and other visual deterrents are all built on the idea of visually scaring birds. This method doesn't work so

well with all species, considering that some species frequently perch on scarecrows. By analogy, people make monkey scarers to protect their crop land in Ethiopia.

## ii. PROPANE CANNONS

It is a propane-powered gas gun which produces a periodic explosion. The audible bang can reach very loud volumes, in excess of 150 decibels, causing a flight reaction in birds. The similarity between a scare cannon and a 12 gauge shotgun is thought to cause a startle/fear reaction, although it is also effective against birds that have not been exposed to hunting pressure. Birds can become habituated to the sound of regular cannon detonations, especially if it does not vary in its magnitude, pitch, or time.

## iii. BALLOONS

Balloons are an inexpensive deterrent. However, this method relies on the movement of balloons, which is something that birds can become used to. The addition of eye illustrations on the balloons has been shown to increase this method's effectiveness as it combats the birds' ability to adapt. Commercially available "scare-eye" balloons have holographic eyes that follow birds wherever they go. The long-term effectiveness of this method can be increased by periodically moving the placement of the scare devices. In the United Kingdom the use of balloons is subject to approval from the Civil Aviation Authority, especially around airfields.

## iv. FIREWORKS

Fireworks can also be used as bird scarers, and some jurisdictions issue special licences for agricultural fireworks. This practice has been criticised as a loophole for the sale of consumer fireworks. Again, the loud bangs can also irritate people living on nearby properties.

## v. DEAD BIRD

The use of model or actual dead birds is used to signal danger to others. Initially, birds often approach the corpse but usually leave when they see the unnatural position of the bird. This approach has been frequently used in attempts to deter gulls from airports. Pheasant feed sacks often have an image of an owl with large eyes so that when empty they can be strung up to scare predators.

## 2. LITERATURE REVIEW

1. The effect of scarers on the presence of starlings (*Sturnus vulgaris*) in cherry orchards by Summers R. W. (December 1985)-A study was carried out on the behaviour of starlings (mainly juveniles) which are pests in cherry orchards where they eat ripening fruit. Observations on 17 radio-tagged starlings during the cherry-picking season showed that most individuals continued to feed in the orchards on consecutive days despite the use of a variety of scarers. Distress calls of starlings played through loudspeakers were effective in that they temporarily scared starlings, but birds returned during the periods when no distress call was played. However, starlings no longer responded to these distress calls after the period between days 7 and 13. Captive starlings could not maintain their weight on a diet of cherries and the maximum daily intake was 25 cherries, amounting to 1.5 times the bird's own weight. The length of time spent in the orchards by radiotagged birds (on average 2.8 hours) was far longer than the time needed to eat 25 cherries. It is concluded that the present arrangement of scarers was inefficient and that the netting-in of an orchard would be more effective.

2. Farmer perceptions of bird damage and control in arable crops by J.D. Coleman and Eric Spurr (2001) - One hundred arable farmers from across New Zealand were randomly selected and interviewed in summer 2000 to assess their perceptions of the nature and extent of bird damage to their crops the bird species involved the factors affecting the level of damage and the type and cost of any bird control undertaken Most farmers considered birds caused serious damage to their crops with wheat barley peas and some speciality seed crops such as brassicas borage and evening primrose most at risk Damage was rarely perceived to exceed 5 in cereals but was often higher in speciality crops It was most severe at seed maturation The birds responsible for most of the damage were house sparrows and greenfinches Most farmers undertook some form of bird control to protect their crops with shooting gas guns and avicides most commonly used The overall expenditure on bird control was far less than the value of the damage reported

3. An Autonomous Bird Deterrent System by Timothy Lewis Clarke (2004)-This paper gives total bird scarer information and its applications, and also shows the different types of bird scarer such as ultrasonic, sonar, eco-friendly, hybrid system, chemical system, etc.

4. The effect of an audible bird scarer in the presence of reed cocks (parphyroporphyro) in rice fields by TurhanKoyucu and FuatLule (2008) - All over the world, birds cause extensive losses to agricultural crops. In order to protect these crops and to send away the birds, some different materials and methods such as chemicals, treatments, colored lights, flash and audible scarers are used. It is possible to see many studies about chemical methods in the literatures, but there is not enough research on audible bird scarers. Therefore, an audible solar powered bird scarer was designed, manufactured and tested on the behaviour of reed cocks (Parphyroporphyro) which are pests and roosted near the rice fields (paddy) where they eat newly seeded rice, in this experimental investigation. The scarer was tested about two weeks during November, 2007. An alarm call of reed cocks was selected for the test of the scarer. Alarm calls of reed cocks played through loudspeaker were seen effective in that they temporarily scared reed cocks. However, reed cocks no longer responded to these alarm calls after the period of 7 days. It is concluded that the present arrangement of scarer was seen inefficient.

5. Design, Manufacture and Test of a Solar Powered Audible BirdScarer by Koyuncu, T [2009]-This paper present the brief idea of solar powered bird scarer. This paper is published in Turkey and gives total idea and also provides four main observations. Total 18 sounds are used in this experiment as it is connected to mp3 player.

6. D. Mohan Kumar "Electronic For You (November 2013)"-This paper presents total circuit diagram and objectives and advantages of solar powered bird sacrer. And also gives the test results and its range and uses. In this paper 7555 IC is used to get the desired output, and Piezo Buzzer is used. The total circuit is powered by solar panel i.e. 6V 300mA.

7. "Crop damage by granivorous birds despite protection efforts by human bird scarers in a sorghum field in western Kenya" by Matthew Hiron,Dianarubene (2014)- This study highlights the impact of avian crop pests on small-scale farmers. Despite having employed personnel that worked enthusiastically throughout the daylight hours, a large proportion of the crop was still damaged. While this kind of damage at the landscape scale may be reduced by diverse cropping patterns and alternated phenology.

8. Accidental blast of an improvised bird scarer gun by Sandeep Kumar Giri,Vinod Kumar, PankajKeshwani (2018)- Blast injuries are encountered frequently these days in the civilian population due to terrorist activities and unsafe use of explosives. Explosive related deaths fall into three categories, namely, accidental, homicidal, and suicidal. Accidental deaths usually occur either at the workplace or when untrained individuals handle legal, unlicensed, or illegal fireworks and inflammable explosive materials or substances. In medico legal practice forensic medicine experts face chemical explosions more commonly as compared to the mechanical explosions. The authors present a case of accidental blast with classical blast injuries and thermal burns due to explosion during mixing up of explosive materials in an improvised bird scarer gun by a farm caretaker The authors present a case of accidental blast with classical blast injuries and thermal burns due to explosion during mixing up of explosive materials in an improvised bird scarer gun by a farm caretaker.

9. Reducing animal pest damage in sunflower fields with nylon net and bird scarers at rajendranagar,Hyderabad.VanamSunitha,VasudevaRaoVaidyula,P. Venkateshwarlu (2021) In order to protect the sunflower crop from parakeets and squirrels at rajendranagar, Hyderabad, two treatments were devised such as bird scarer and nylon net during maturity stage of the crop . the result revealed that he yield of sunflower crop protected by nylon net was higher than bird scarer protected field. However, protection by bird scarer was found to be cheaper than use of nylon net.

### 3. METHODOLOGY

#### 1. Operation

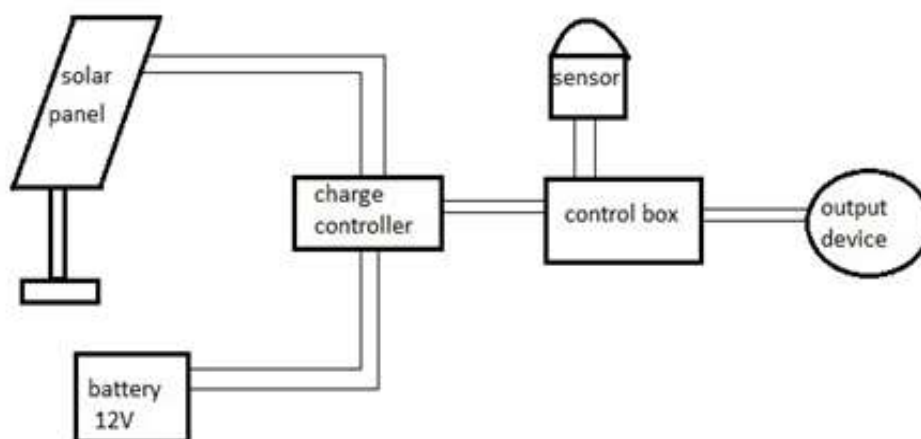

**Fig-1. Shows Layout of the Prototype.**

It consists of a solar panel, 12V battery setup, solar charge controller, microcontroller, PIR sensors and output device. As we studied from the solar panel gives a D.C. output of 12V this D.C. output is not always constant there is some variation in this D.C. output this cannot be given to the battery storage it may weaken the life of the battery. So in order to get constant D.C. output and also to avoid the reverse flow of current to the panel in the case of no load a charge controller has been used this helps us to allow only the constant voltage of 12V D.C. to the battery. The microcontroller is used to control sensors and buzzers. The Ultrasonic sensor is used which is an electronic sensor that detects motion of an object in its field of view. Output device such as a buzzer is used to produce a desired frequency of sound range which is used to distress a bird.

#### 2. Materials required

TABLE 1: Materials required

SI.NO	COMPONENTS	QUANTITY
1	Solar panel	1
2	Solar charge controller	1
3	Battery	1
4	Arduino / IC555	1
5	Ultrasonic sensor	4
6	Output device	2
7	Connecting wires	As much required

#### 3. Ultra sonic sensor

Ultrasonic ranging and detecting devices make use of high-frequency sound waves to detect the presence of an object and its range. These systems either measure the echo reflection of the sound waves from objects or detect the interruption of the sound beam as the objects pass between the transmitter and receiver. An ultrasonic sensor typically utilizes a transducer that produces an electrical output pulse in response to the received ultrasonic energy. In such case, the horizontal aperture angle must be at least 8 degrees for an inter-vehicle distance of 75 meters. The vertical aperture is fixed to be 1 degree and is positioned in such a way to avoid fault reading due to the road conditions.

#### 4. Arduino NANO

Arduino is an open-source electronics platform based on easy-to-use hardware and software. Arduino boards are able to read inputs - light on a sensor, a finger on a button, or a Twitter message - and turn it into an output - activating a motor, turning on an LED, publishing something online. You can tell your board what to do by sending a set of instructions to the microcontroller on the board. To do so you use the Arduino programming language (based on Wiring), and the Arduino Software (IDE), based on Processing.

#### 5. Solar Panel

The process of converting light (photons) to electricity (voltage) is called the solar photovoltaic (PV) effect. Photovoltaic solar cells convert sunlight directly into solar power (electricity). They use thin layers of semi-conducting material that is charged differently between the top and bottom layers. The semi-conducting material can be encased between a sheet of glass and/or a polymer resin. When exposed to daylight, electrons in the semi-conducting material absorb the photons, causing them to become highly energised. These move between the top and bottom surfaces of the semi-conducting material. This movement of electrons generates a current known as a direct current (DC). This is then fed through an inverter, which converts the power to alternating current (AC).

#### 6. Battery

The electricity produced by your solar system is stored in deep-cycle lead acid batteries that look very similar to the ones found in most cars today (although structurally different). The two most popular types of battery are GEL and Absorbed Glass Mat (AGM), which store the charge very well and do not degrade nearly as fast as the common lead acid (wet cell) battery. Both types of batteries are designed to gradually discharge slowly and recharge 80% of their capacity a multiple number of times. Solar photovoltaic batteries tend to operate at 12 volts, and can be arranged in banks (multiple batteries), increasing the storage potential of your solar photovoltaic set up. A bank of batteries organized in a series increases the capacity of your storage but also increases the voltage delivered from your bank, while multiple batteries organized in a parallel circuit increase the capacity but keep the voltage the same.

#### 7. Sound output device

Output device like speakers and sound producing equipment's are used to give distress call to birds

### 4. RESULTS AND DISCUSSIONS

The bird scarer works in day time with use of solar energy, in the absence of solar radiation it efficiently work with the help of battery where the electrical energy is stored by using solar panel. The utilization of ultrasonic waves; which human ears don't recognize, however are seen by little winged animals is a novel innovation that can viably repulse such feathered creatures from assigned spots. The bird scarer detects birds upto 4 meter and produces the sound effect which is uncomfortable for birds so that they fly away.

### 5. CONCLUSION

The effort of project results in effective bird scarer which helps farmer to be free from his tension by making use of solar energy. The solar energy eliminates external electricity requirement. The detection range is also increased effectively also it produces a sound effect which scares birds without harming them. The project requires no man surveillance.

### REFERENCES

1. Wiens J. A. and Dyer M. I. (1977). "Assessing potential impact of granivorous birds in ecosystems; in Granivorous birds in ecosystems (eds) J Pinowski and S C Kendeigh". London: Cambridge Univ. Press. pp 205-268.
2. Bruggers R. L. and Ruelle P. (1982). "Efficacy of nets and fibers for protecting crops from grain-eating birds in Africa". Crop Protection, 1(1), pp. 55-65.

3. Summers R. W. (1985). "The effect of scarers on the presence of starlings (*Sturnus vulgaris*) in cherry orchards". *Crop Protection* 4 (4), pp. 520- 528.
4. Vickery J. A. and Summers R. W. (1992). "Cost-effectiveness of scaring brent geese *Branta b. bernicla* from fields of arable crops by a human bird scarer", *Crop Protection* 11 (5), pp. 480-484.
5. York D. L., Cummings J. L., Engeman R. M., and Davis Jr. J. E. (2000). "Evaluation of Flight Control and Mesurol as repellents to reduce horned lark (*Eremophila alpestris*) damage to lettuce seedlings". *Crop Protection*, 19(3) pp. 201-203
6. Coleman J. and Spurr E. (2001). "Farmers Perceptions of Bird damage and Control in Arable Crops". *New Zealand Plant Protection*, 54:184-187.
7. Saglam C. and Onemli F. (2005). "The effects of sowing date and sowing density on birds damage in the cultivators of sunflower (*Helianthus annuus L.*)". *Journal of Tekirdag Agricultural Faculty*, 2 (1), pp. 50-57.
8. Avery M. L., Werner S. J., Cummings J. L., Humphrey J. S., Milleson M. P., Carlson C. J., Primus T. M. and Goodall M. J. (2005). "Caffeine for reducing bird damage to newly seeded rice". *Crop Protection*, Vol. 24, pp. 651-657.
9. The effect of a audible bird scarer in the presence of reed cocks (*parphyroporphyro*) in rice fields by TurhanKoyucu and FuatLule (2008)
10. Koyuncu T. and Lule F. (2009). "Design, Manufacture and Test of a Solar Powered Audible Bird Scarer". *International Journal of Agricultural and Biosystems Engineering*, 3(6).

