

Fabrication of Mask Vending Machine

¹ Shivam Singh,² Sayooj Sajith,³ Shekhar Attri,⁴ Sharanbasav,⁵ Dr. Manjunatha L.H

¹²³⁴Student, ⁵ Professor,

School of Mechanical Engineering, REVA University, Bengaluru, India.

Abstract : Due to COVID-19, there are some set of rules to be followed in this pandemic situation. Usage of face mask or coverings is one of the preventive measures suggested to further avoid the spread of virus. The mask vending machine provides access of mask to places that are inaccessible because of various factors, particularly in remote areas. Also, the time spent for going for a hospital and drug store can be avoided. The main objective of the work is to provide face mask to the user with ease and without human intervention. The project contains a storage area with slots to store the masks. A Coin Sensor, to identify and reject coins connected to a Micro Controller Arduino Nano. The input provided by the user is forwarded to the Microcontroller for process. The Microcontroller, with the assistance of the motor drivers, drives the DC Motor, which is further connected to a metallic rod. This rod revolves a complete 360° turn. The rotating motions of this rod dispense the mask which falls from the slot. The Micro Controller is connected to rechargeable batteries. The machine has been made by Mild Steel. This material was chosen for its simple handiness and weldability. The machine would be highly useful in country like India and can be placed near schools, colleges, hospitals and other densely populated areas. Looking at the necessity of masks, a mask vending machine seems an appropriate project for final year engineering students.

Index Terms - Arduino Nano, Coin Sensor, DC Motor.

I. INTRODUCTION

The basic design of a vending machine begins with the cabinet, the steel outer shell that holds all internal components and which determines the machine's overall size and shape. Inside the cabinet is a steel inner lining called the tank. The tank and the cabinet fit closely together, leaving enough room in-between for a layer of polyurethane foam insulation. In combination, the tank and the foam insulation help keep internal temperatures stable and protect products against temperature extremes outside the cabinet. Although all products and dispensing mechanisms are contained in the cabinet, in the strictest sense, they are actually installed within the tank.

The outer surfaces of the cabinet are coated with an acrylic powder finish that is baked into place. Powder coatings enable the machine to withstand extreme temperatures, salt or sand, abuse by customers, and other conditions requiring high surface durability.

To store and dispense products, can feeder stack columns or feeder trays are installed inside the machine. Each tray is equipped with a large rotating wire spiral that holds the products. Feeder trays slide in and out of the machine for easy maintenance and restocking of merchandise. The feeder stacks and trays also contain the motor controls that physically push the products forward until they are released from the stack and fall to the access area. When a customer selects a product, a rotor turns and advances a single item, dropping cans or bottles one at a time. In the same way, spirals on snack food trays rotate and push products forward until they fall off the tray.

Some vending machines, especially cold drink vendors, have two doors. The internal door seals the inside of the machine and provides additional insulation. The, outer door contains the electronic controls that allow customers to purchase and receive goods. The outer door also includes signage and illustrations, generally silk-screened onto a panel of Lexan that fits into the front panel of the door. Lighting for the front panel is generally installed behind the Lexan panels. The outer door includes heavy-duty hasps, locks, and hinges to deter theft and vandalism.

Electronic components, such as coin and bill validators, test coins and scan dollar bills that have been inserted to ensure that the cash is genuine and in the proper amount. A panel of control buttons lets customers make their selections. These buttons are connected to the motor controls of the feeder stacks and trays, activating the rotors that release products to the bins. Change-makers hold quantities of coins and release the correct change after a selection has been made. More recent machines may also include card validators for accepting debit and credit cards, LCD panels with pricing details and machine status information, and speech chips that give transaction details to customers by voice.

Design changes occur most frequently in the mechanisms for handling and dispensing the vast number of different types of bottles, cans, boxes, bags, and other packages available on the market. When 20 oz (592 ml) plastic soda bottles were first introduced to vending, they tended to jam in the machine. Designers had to re-work the way those bottles were stored in the machine and delivered to the customer. Constant changes in product packaging have ensured that designers must always look for practical and more efficient ways to vend products.

II. LITERATURE REVIEW

Vennan Sibanda, et al. [1] studied to save time by 75% to 83%. The aim of this paper is to design a high-tech vending machine that can dispense a variety of products at the same time using fingerprint sensors and other high technological features for security and user-friendliness.

SivasubramaniyanS, et al.[2] aims to bring one step solution to the people for their medical treatment which includes online diagnosis, online consultation with medical experts and providing generic medicines.

AyanBanik[3] suggested that all the public places must include Integrated Hand Sterilizer with Alcohol Sanitizers, UV rays and Hand Drier. There is ample evidence that hand antisepsis reduces the transmission of healthcare- associated pathogens and the incidence of HCAI.

Kamalanathan.P,et al.[4] have studied that usage of paper is inevitable and its demand is increasing steadily particularly in the places such as educational institutions, government offices, etc.

Dimple Thakwani, et al. [5] have found that change dispensing vending machines are used to provide change to the user as per the denomination of note given to the machine by the user. Change dispensing vending machine using PLC can be implemented using various devices or techniques such as transistors, transducers, sensors and image processing technique.

A.Krishna Kumar, et al.[6] Studied that vending machines are more accessible and practical than the convention purchasing method now. The paper aims to design a vending machine that can dispense three products of different prices with additional features of 'return change' when a coin of higher denomination is inserted and 'return money' when request is cancelled.

Ping Li1a, et al.[7] Have Prospective in mind that vending machines must offer efficient service with zero tolerance for human error, require no user training and be accessible to a wide range of users.

Dragan S. Jankovic,et al.[8] proposes a modification of the existing concept of a vending machine for distributing drugs (medication vending machines – MVM), which would enable better social distancing in the case of pandemics/epidemics, such as the current COVID-19 pandemic.

Zhiliang Kang, et al.[9] addresses the problems of low selling efficiency, poor sanitation conditions, labor-intensive requirement, and quick rice cooling speed in manual rice selling in cafeterias, especially in colleges and secondary schools, this paper presented an Advanced RISC Machines (ARM) microprocessor-based rice-selling machine for cafeterias.

Melissa Matthews[10] proposed that Vending machines may be contributing to the obesogenic food environment. The Health Density Vending Machine Audit Tool (HDVMAT) was developed to comprehensively evaluate and score vending machines based on machine accessibility, product healthfulness, price, and promotion.

Akshay Naxine, et al.[11] researched on Cashless Payment Vending Machine which is introduced to reduce the man power, time and cash payments.

Mrs. K. S. Sujatha, et al.[12] tells about the Indian government, which is trying to deal with the problem of underdeveloped Rural Hospitals, as these places are in drastic need of health care, doctors and medicines.

Rakshitha A, et al[13] studied on accessibility to basic healthcare is an important cornerstone of development towards building a healthy future. This project presents a machine designed to provide such healthcare at areas where having a medical store may not be feasible or possible.

Shrikant Bhange, et al.[14] studied on degrees of social status are closely linked to health inequalities. Those with poor health tend to fall into poverty and the poor tend to have poor health.

P.Pradeepa, et al.[15] researched on vending machines which are used to dispense small different products, when a coin is inserted. These machines can be implemented in different ways by using microcontroller and FPGA board.

Mr. Ajinkya A. Mali, et al.[16] have studied on technology that is developing in food industry with the help of automation. Usually, there is tremendous crowd at Snack Centers, Bhel Stalls near gardens, hospitals, and colleges.

M Balubai, et al.[17] researched on reverse vending machine which is a concept or an idea which inculcate the habit of recycling the waste materials. Reverse vending machine will be working by taking recyclable waste into the machine and gives a use full thing as a token of appreciation.

Manish Kumar, et al.[18] presented a Low Power 'Pay Power' Automatic Electronic Vending Machine design. A simple coin detection mechanism is employed to detect a coin of a single type and taking appropriate action using a PIC 16F877A microcontroller.

Sonika Rao,et al.[19] have studied vaccination is assumed to be a pivotal part in looking after wellbeing, averting sickness, overseeing, constant conditions and curing ailment. All Time Medicine (ATM) is a machine which delivers the medicine in emergency cases and ensure availability of drugs 24x7 and hence the name "All Time Medicine".

J. V. BhanuTej, et al.[20] studied on Automated Book Vending Machine. It is a device which reduces the human effort of maintaining the complicated databases for the books included, the books borrowed and the book returned.

N. Nithya, et al.[21] researched on the VLSI based first aid vending machine in highways is used to dispense first aid items and basic monitoring devices for the persons who need immediate attention during accidents in highways.

M.Bhuvaneshwari, et al.[22] research paper is based on the concept of automatic ticket vending machine by using RFID and Zigbee technique. In order to ensure the passenger journey with no quarrels and mess we employ this ticket friend solution that replaces the traditional paper ticketing by RFID tickets and vouchers, vended through automated machine using smart cards, which improves the convenience and security of transaction.

K.R.Nimisha, et al.[23] studied on the usage of newspaper which is inevitable and its demand is increasing steadily particularly in the places such as educational institutions, Railway stations, etc.

Aswathy B, et al.[24] studied on the Public Distribution System (PDS), established by the Government of India under Ministry of Consumer Affairs, Food, and Public Distribution to distribute grocery items to poor people at fair price is facing significant threats to its very existence.

NATHEESAN S[25] studied on automation system that has become a vital component of industries and assembling plants in ensuring increased productivity and managing growing demands.

Ayman Alharbi [26] proposed a design and implementation technique for smart gift vending machine using biometric based authentication.

Abhishek Singh[27] studied development in technology is taking place rapidly, from microelectronics to nano technology; from mobile phone to foldable phones everything has passed to major changes in terms of ideas and innovations.

Jagruti Sahuji, et al.[28] published a paper. This paper proposes the design of Automatic Vending Machine Using IOT. The main objective of our project is to launch new technology application in society. The implementation of IOT based vending machine helps the customer to order the chocolate.

B Jyothi, et al.[29] studied on vending machine which dispenses items such as snacks, beverages, lottery tickets, consumer products and even gold and gems to customers automatically, after the customer inserts currency or card into the machine.

Rahul Jadhv, et al.[30] researched on the vending machine which provides the beverage like snacks, cold drink, it is also used for ticketing. These systems are operated on either coin or note or manually switch operated. This paper presents system which operates not on coin or note, it operates on RFID system.

III. MATERIALS

3.1 Mild Steel

Mild steel is a type of low carbon steel. Carbon steels are metals that contain a small percentage of carbon (roughly between 0.05% and 0.25%) which enhances the properties of pure iron.



Fig 1: Mild steel sheets



Fig 2: Hollow mild steel

3.2 Arduino NANO

Arduino is an open-source electronics platform based on easy-to-use hardware and software. Arduino boards are able to read inputs - light on a sensor, a finger on a button, or a Twitter message - and turn it into an output - activating a motor, turning on an LED, publishing something online. You can tell your board what to do by sending a set of instructions to the microcontroller on the board. To do so you use the Arduino programming language (based on Wiring), and the Arduino Software (IDE), based on Processing.

Over the years Arduino has been the brain of thousands of projects, from everyday objects to complex scientific instruments. A worldwide community of makers - students, hobbyists, artists, programmers, and professionals - has gathered around this open-source platform, their contributions have added up to an incredible amount of accessible knowledge that can be of great help to novices and experts alike.

Arduino was born at the Ivrea Interaction Design Institute as an easy tool for fast prototyping, aimed at students without a background in electronics and programming. As soon as it reached a wider community, the Arduino board started changing to adapt to new needs and challenges, differentiating its offer from simple 8-bit boards to products for IoT applications, wearable, 3D printing, and embedded environments. All Arduino boards are completely open-source, empowering users to build them

independently and eventually adapt them to their particular needs. The software, too, is open-source, and it is growing through the contributions of users worldwide.



Fig 3:Arduino Nano

Table 1 Specifications of theArduino NANO

Cc	ATmega328P
Architecture	AVR
Operating Voltage	5 Volts
Flash Memory	32 KB of which 2 KB used by Bootloader
SRAM	2KB
Clock Speed	16 MHz
Analog I/O Pins	8
EEPROM	1 KB
DC Current per I/O Pins	40 milliAmps
Input Voltage	(7-12) Volt

3.3 Li-ion Rechargeable Battery

A lithium-ion battery or Li-ion battery is a type of rechargeable battery. Lithium-ion batteries are commonly used for portable electronics and electric vehicles. During discharge, lithium ions (Li+) carry the current within the battery from the negative to the positive electrode, through the non-aqueous electrolyte.

During charging, an external electrical power source (the charging circuit) applies an over-voltage (a higher voltage than the battery produces, of the same polarity), forcing a charging current to flow within the battery from the positive to the negative electrode, i.e. in the reverse direction of a discharge current under normal conditions. The lithium ions then migrate from the positive to the negative electrode, where they become embedded in the porous electrode material in a process known as intercalation.



Fig 4.: Rechargeable Battery

3.4 Coin sensor

A coin detector and counter comprising a coreless oblong transmitter coil and a coreless oblong receiver coil spaced apart on opposite sides of a coin path arranged to cause the entire diameter of each coin to pass between the coils. The maximum peak voltage generated in the receiver coil upon passage of each coin is measured as a determination of the conductance of each coin. By comparing the measured conductance of each coin with the known conductance of coins, each coin is thereby identified and counted.

- This coin booth working on 12 volt
- We set to receive the 5 Rupee coin only

Table 2 Specifications of the coin sensor-

Power source:	DC 12 ± 10%
Coin diameter:	15mm to 29mm
Coin thickness:	1.8mm to 3mm
Operating temperature:	10 degree Celsius to 60 degree celsius



Fig 5.: Multi Coin Selector

3.5 DC motor

A battery is a power source consisting of one or more electrochemical cells with external connections for powering electrical devices

Table 3.5: Specifications of the DC motor:-

Voltage:	12 volt
Speed:	40 rpm
Power:	5 watts



Fig 6.: 12V DC Motor

IV. EXPERIMENTAL DETAILS

The aim of our project is to fabricate a mask vending machine which helps in reducing time for buying of a mask. The mask vending machine is battery operated. A frame is made up of mild steel which gives the desired strength and lightness to the body of the machine. The coin sensor is assembled inside the body, which is coupled with a microcontroller. The function of microcontroller is to read the coin and send the signal to the DC motor. Upon receiving the signal from the microcontroller, the motor rotates one full circle and push the mask through the outlet of the machine. The whole machine runs on a rechargeable batteries.

4.1 Flowchart of Mask Vending Machine

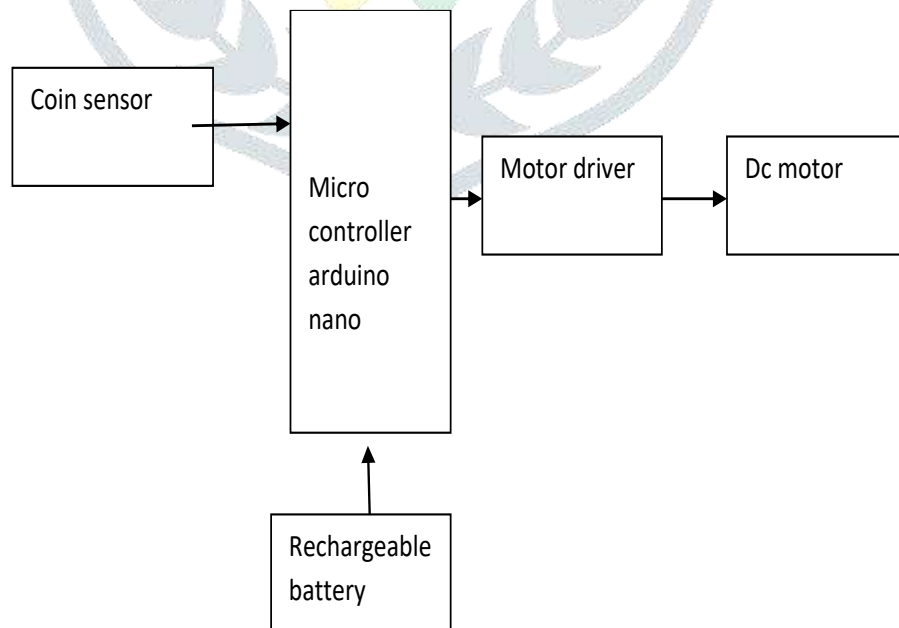

Fig 7: Flowchart of mask vending machine

4.7 The outer structure of the model



Fig 8.: Front view of the structure



Fig 9.: Top view of the structure

Dimensions :- Height X Width X Thickness
38 X 30 X 30

Note:- All dimensions are in centimeters

V. RESULTS AND DISCUSSION

The input denomination for the mask vending machine is the new 5 rupee coin. No other denomination is accepted by the machine. Once the coin is put inside the coin input slot, the microcontroller checks for the authenticity of the coin. The microcontroller is connected to rechargeable batteries. The level start is a metallic rod connected to a 12 volt DC Motor. Once the authenticity is defined, the motor which is connected to the lever starts rotating and completes a 360° turn. This rotating motion of metallic rod forces the object to dispense and the mask is slid out of the machine slot. Thus providing the user with the desired product.

The machine is easy and is extremely straightforward to control. In future the project can be extended with addition of few more variety of masks. The coin acts as the medium that completes the detection circuit. A 5V power supply is used to drive the microcontroller. The event of coin detection is morphed as an external interrupt to the microcontroller and is received at pin RB0 by the microcontroller. The microcontroller is programmed in such a way that this interrupt increments a counter which indicates the number of coins inserted by the user. But the maximum number of coins to be inserted has been limited to four (two-rupee coins)[18].



Fig 10.: Outer and inner structure of reverse vending machine[18]

A DC motor is any of a class of electrical machines that converts direct current electrical power into mechanical power. The most common types rely on the forces produced by magnetic fields. Nearly all types of DC motors have some internal mechanism, either electromechanical or electronic; to periodically change the direction of current flow in part of the motor. Most types produce rotary motion; a linear motor directly produces force and motion in a straight line. In this project, the DC Motor of 12V, 5A is used[23].

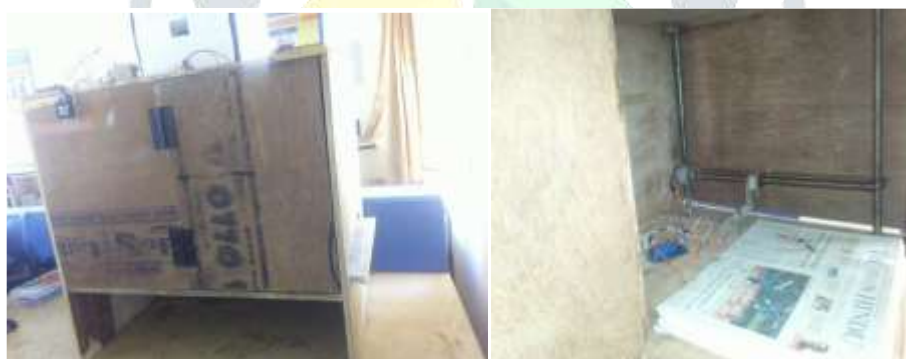

Fig 11.: Outer and inner structure of newspaper vending machine[23]

Arduino is an open-source prototyping platform used for building electronics projects. It consists of both a physical programmable circuit board and a software, or IDE (Integrated Development Environment) that runs on your computer, where you can write and upload the computer code to the physical board, differentiating it from simple 8-bit boards to products for IoT applications, wearable, 3D printing, and embedded environments. Arduino can interact with buttons, LEDs, motors, speakers, GPS units, cameras, the internet, and even your smartphone or your TV. A motor controller or driver is a device or group of devices that serves to govern in some predetermined manner the performance of an electrical motor. A motor controller might include a manual or automatic means for starting and stopping the motor, selecting forward or reverse rotation, selecting and regulating the speed, regulating or limiting the torque, and protecting against overloads and electrical faults.[20].



Fig 12.: Outer structure of book vending machine[20]

REFERENCES

1. VennanSibanda*, Lorraine Munetsi^b, KhumbulaniMpfu^a, EriyetiMurena, John Trimble , “Design of a Control System for a Vending Machine”, Volume 91, 2020, Pages 758-763, <https://doi.org/10.1016/j.procir.2020.04.136>
2. Sivasubramaniyan, SSrivarshiniM. , Deepthi P. S. , Dr. Janarthanan P. “Any time medical assistance and medicine vending machine using machine learning.” International Journal of Advance Research, Ideas and Innovations in Technology 5 (2019): 628-631.
3. Banik, Ayan, “Portable Integrated Hand Sterilizer and Dispenser to Ensure Hand Hygiene and Subsidized Facial Mask” March 26, 2020. <https://ssrn.com/abstract=3561696> or <http://dx.doi.org/10.2139/ssrn.3561696>
4. Kamalanathan.P, Irshath Ahmed. R,Mohamed Aamir. M, Kalaiselvan. P, Associate Professor, Department of Mechanical Engineering,“Automatic paper vending machine”, IFET College of Engineering, Villupuram, Tamil Nadu, 2015.
5. Dimple Thakwani, Dr. N Tripathi. “PLC based change dispensing vending machine using image processing technique for identifying and verifying currency”,Volume: 03 Issue: 11 ,Nov -2016
6. A.Krishna Kumar, G. Ashritha, D.Deepika, Assistant Professor, "Design of vending machine using veriloghdl", Dept of CSE, Mahatma Gandhi Institute of Technology, Hyderabad International Journal of Emerging Technologies and Innovative Research (www.jetir.org), ISSN:2349-5162, Vol.5, Issue 7, page no.1346-1350, July-2018 <http://www.jetir.org/papers/JETIRC006233.pdf>
7. Ping Li, Cheng Li, “A Study of Vending Machine Interface System and User Behavior on Multi-interface Vending Machine Improved Design”, April, 2015. <https://dx.doi.org/10.2991/cmes-15.2015.106>
8. D. S. Jankovic, A. M. Milenkovic and A. I. Djordjevic, "Improving the Concept of Medication Vending Machine in the Light of COVID-19 and other Pandemics," 2020 55th International Scientific Conference on Information, Communication and Energy Systems and Technologies (ICEST), Niš, Serbia, 2020. [10.1109/ICEST49890.2020.9232916](https://doi.org/10.1109/ICEST49890.2020.9232916).
9. ZhiliangKang ,Lijia Xu , Chen Li ,Tangui He and NocklosTenret.”Design of an ARM-based Automatic Rice-Selling Machine for Cafeterias,” College of Mechanical and Electrical Engineering, Sichuan Agricultural University, Ya’an 625014, China, Journal of Engineering Science and Technology Review 9 (1) (2016) 95-101 <http://www.jestr.org/>
10. Melissa Matthews.”Development, Implementation, and Validation of the Health Density Vending Machine Audit Tool (HDVMAT),” Theses - ALL. 27
11. AkshayNaxine, PranaliDhanjode, Priyanka Kapgate, Nikita Sonkusare, P.B. Pokle. ”Cashless Payment Vending Machine With Automatic Hand Sanitizer”,Department of E&TC Engineering, Priyadarshini J.L. College of Engineering, e-ISSN: 2582-5208 International Research Journal of Modernization in Engineering Technology and Science Volume:02/Issue:05/May-2020
12. Mrs. K. S. Sujatha, Varshini Bhaskaran , Subbiah. S& S. Shruthi.”Cloud Computing based E-Vending Machine for Rural Areas”,Department of ECE, Easwari Engineering College, Ramapuram, Chennai.Imperial Journal of Interdisciplinary Research (IJIR) Vol-2, Issue-6, 2016 ISSN: 2454-1362
13. Rakshitha A, Hema E, Priya G V, Rakshitha V, Sapna.”Automatic Medicine Vending Machine ”Department of ECE, Sambhram Institute of Technology, Bangalore, India. International Journal of Management, Technology And Engineering Volume 8, Issue X, OCTOBER/2018 ISSN NO : 2249-7455

14. Shrikant Bhange, Kaveri Niphade, Tejshri Pachorkar, Akshaypansare, "Automatic Medicine Vending Machine", Department of E&TC, SITRC, Nashik, Maharashtra, India. International Journal of Advanced Research in Electronics and Communication Engineering (IJARECE) Volume 4, Issue 3, March 2015
15. P.Pradeepa, T.Sudhalavanya, K.Suganthi, N.Suganthi, M. Menagadevi, "Design And Implementation Of Vending Machine Using Verilog HDL", Department of ECE, K.S.Rangasamy College of Technology, Tiruchengode. International Journal of Advanced Engineering Technology E-ISSN 0976-3945 IJAET/Vol. IV/ Issue I/Jan.-March., 2013/51-53 Research Paper
16. Mr. Ajinkya A. Mali, Dr. Mahadev S. Patil, "Automatic Bhel Vending Machine ", Department of Electronics and Telecommunication Engineering, Rajarambapu Institute of Technology, Rajaramnagar, Sangli (M.S.), India. International Conference on Recent Trends in Engineering, Science, Technology and Management
17. M Balubai, Vamsikiran Sure, V Manil Reddy, Sai Reddy Gowtham, Dr.Ram.Subbiah, "A New Approach in Manufacturing of Reverse Vending Machine", Mechanical Department, GRIET Hyderabad, Telangana, India. International Journal of Advanced Engineering, Management and Science (IJAEMS) [Vol-3, Issue-7, July- 2017] ISSN: 2454-1311
<https://dx.doi.org/10.24001/ijaems.3.7.5>
18. Manish Kumar, Vinay Kumar Deolia, "Designing and Development of a Low Power Electronic vending machine using PIC 16F877A controller", Department of Electronics and Communication, GLA University, Mathura. European Journal of Molecular & Clinical Medicine ISSN 2515-8260 Volume 7, Issue 4, 2020
19. Sonika Rao, Susmitha Anand, Shilpa R, Nithin H S, Kanakaraju R, "All Time Medicated Vending Machine", National Conference on Communication and Image Processing (NCCIP- 2017) 3rd National Conference by TJIT, Bangalore. International Journal of Science, Engineering and Technology
20. J. V. Bhanu Tej, M. Sai Sankaran, A. M. Anudeep, Bhargav Kasa, "Automation Of The Book Vending Machine", Anil Neerukonda Institute Technology and Sciences, Visakhapatnam – 531162, Andhra Pradesh, India. JAC : A journal of composition theory Volume XIII, Issue IV, APRIL 2020 ISSN : 0731-6755
21. N. Nithya, R.S. Janarthanam, A. Narmatha, P.T. Sree Lakshmi, "A Novel Highway First-Aid Vending Machine", Akshaya College of Engineering and Technology, Coimbatore, India. 2019 IJESC Volume 9 Issue No.3
[19-O-Suku_Mar-EMBEDDED.pdf](#)
22. M.Bhuvaneshwari, S.Sukumar, N.Divya, S.Kalpanadevi, N.Suthanthira Vanitha, "Embedded System Based Automatic Ticket Vending Machine for Modern Transport System", Department of Electrical & Electronics Engineering, Knowledge Institute of Technology, Salem, India. International Journal of Advanced Research in Computer and Communication Engineering Vol. 2, Issue 11, November 2013
[ajast-30.pdf](#)
23. K.R.Nimisha, K.Indumathi, R.Divyamani, R.Kavya, K.Gowrimanokari, "Smart Newspaper Vending Machine", Department of ECE, Sri Eshwar College of Engineering, India. Asian Journal of Applied Science and Technology (AJAST) Volume 1, Issue 1, Pages 131-136, February 2017
[NFTPCOS-18-18085.pdf](#)
24. Aswathy B, Jasna Basheer, Vishnu R, Preethish Babu S, "Automated Ration Vending Machine", Dept of Electrical and Electronics Engineering, College of Engineering Perumon, Kollam, India. International Journal of Innovative Research in Electrical, Electronics, Instrumentation and Control Engineering NFTPCOS-18 National Conference on Future Technologies in Power Control and Communication Systems College of Engineering Perumon, Kollam, Kerala Vol. 1, Special Issue 2, March 2018
25. Natheesa S, "Design And Implementation Of Mechatronics Based Vending System", Eng (Hons) Mechatronics Engineering - Birmingham City University, United Kingdom. International Journal of Mechanical And Production Engineering, ISSN: 2320-2092, Volume- 5, Issue-2, Feb.-2017
26. Ayman Alharbi, "Vending Machine for Smart Gifting Under-Privileged People", Computer Engineering & Deputy General Supervisor of Investment Management, Umm Al-Qura University, Kingdom of Saudi Arabia. ISSN: 2455-2631 January 2020 IJSDR | Volume 5, Issue 1
27. Abhishek Singh, "Touch Screen Based Automated Medical Vending Machine", Department of Electronics Engineering Dwarkadas J Sanghvi College of Engineering. IJRST – International Journal for Innovative Research in Science & Technology | Volume 1 | Issue 11 | April 2015 ISSN (online): 2349-6010
28. Jagruti Sahuji, Dnyaneshwari Takl, Bhagyashree Tongire, Vishwashri. A.Kulkarni, "Automatic Chocolate Vending Machine Using IOT", Dept. of Electronics and Telecommunication Engineering, MGM's JNEC Aurangabad. The International journal of analytical and experimental modal analysis Volume XII, Issue VI, June/2020 ISSN NO:0886-9367

29. B Jyothi, I. Sarah, A. Srinivas,"Implementation of FPGA Based Smart Vending Machine",CMR College of Engineering &Technology , Assoc. Prof, E.C.E Dept., Hyderabad, India. International Journal of Engineering Research and Applications (IJERA) ISSN: 2248-9622 NATIONAL CONFERENCE on Developments, Advances & Trends in Engineering Sciences (NCDATES- 09 th& 10th January 2015)
30. Rahul Jadhv, MrunaliJejurkar, PranitaKave& Prof. H.P. Chaudhari,"Smart Coffee Vending Machine Using RFID",Instrumentation Engineering department, AISSM'S IOIT, Pune, Maharashtra-411001, India.Advances in Wireless and Mobile Communications. ISSN 0973-6972 Volume 10, Number 4 (2017), pp. 793-800 © Research India Publications <http://www.ripublication.com/>

