

Development and Characterization of Advanced Fiberglass Composites

Prathamesh Shingan, Pratik Kulabkar, Sudhanshu Bhure, Nikhil Patil,

Nandakumar Vele

Department Of Mechanical Engineering, PCCOE&R

prathameshshingan009@gmail.com sbhure12356@gmail.com

kulabkarpratik@gmail.com

Abstract - In the present age of technological innovation in various sectors ranging from automobile to aerospace, high strength materials with low weight are in high demand. The strength to weight ratios of composite materials using glass fibers, carbon fiber etc make them ideal choice for application in several fields. Composite materials are proved as suitable substitutes for steel in connection with weight reduction of the vehicle. Hence, the composite materials have been selected for specimen. The commonly used fibers are carbon, glass, kevlar, etc. Among these, the glass fiber has been selected based on the cost factor and strength. The types of glass fibers are C-glass, S-glass and E-glass. The C-glass fiber is designed to give improved surface finish. S-glass fiber is design to give very high modular, which is used particularly in aeronautic industries. The E-glass fiber is a high quality glass, which is used as standard reinforcement fiber for all the present systems well complying with mechanical property requirements. Thus, E-glass fiber was found appropriate for this application and thus the tensile and flexure specimen have being prepared accordingly with varying composition of Al_2O_3 and SiO_2 . The design of the specimen geometry was done using Unigraphics Nx and the ACP analysis was done using Ansys Workbench. The specimens were manufactured and tested using suitable methods, the results of same are in close agreement.

Keywords: Tensile, Flexure, Al_2O_3 , SiO_2 , ACP analysis, E-glass fiber.

I. INTRODUCTION

Fiberglass (American English), or fibreglass (Commonwealth English), is a common type of fiber-reinforced plastic using glass fiber. The fibers may be randomly arranged, flattened into a sheet (called a chopped strand mat), or woven into glass cloth. The plastic matrix may be a thermoset polymer matrix— most often based on thermosetting polymers such as epoxy, polyester resin, or vinyl ester resin—or a thermoplastic. Cheaper and more flexible than carbon fiber, it is stronger than many metals by weight, is non-magnetic, non-conductive, and transparent to electromagnetic radiation, can be molded into complex shapes, and is chemically inert under many circumstances. Applications include aircraft, boats, automobiles, bath tubs and enclosures, swimming pools, hot tubs, septic tanks, water tanks, roofing, pipes, cladding, orthopedic casts, surfboards, and external door skins. The results of tensile tests are used in selecting materials for engineering applications. Tensile properties frequently are included in material specifications to ensure quality. Tensile properties often are measured during development of new materials and processes, so that different materials and processes can be compared. Finally, tensile properties often are used to predict the behavior of a material under forms of loading other than uniaxial tension. The strength of a material often is the primary concern. The strength of interest may be measured in terms of either the stress necessary to cause appreciable plastic deformation or the maximum stress that the material can withstand. These measures of strength are used, with appropriate caution (in the form of safety factors), in engineering design. Also of interest is the material's ductility, which is a measure of how much it can be deformed before it fractures. Rarely is ductility incorporated directly in design; rather, it is included in material specifications to ensure quality and toughness. Low ductility in a tensile test often is accompanied by low resistance to fracture under other forms of loading. Elastic properties also may be of interest, but special techniques must be used to measure these properties during tensile testing, and more accurate measurements can be made by ultrasonic techniques.

II. METHODOLOGY

A. Selection of Materials

1. Fibres Selection

The commonly used fibers are carbon, glass, kevlar, etc. Among these, the glass fiber has been selected based on the cost factor and strength. The types of glass fibers are C-glass, S-glass and E-glass. The C-glass fiber is designed to give improved surface finish. S-glass fiber is design to give very high modular, which is used particularly in aeronautic industries. The E-glass fiber is a

high quality glass, which is used as standard reinforcement fiber for all the present systems well complying with mechanical property requirements. Thus, E-glass fiber was found appropriate for this application.

2. Glassfiber Details

Glass fiber properties, such as tensile strength, Young's modulus, and chemical durability, are measured on the fibers directly. Other properties, such as dielectric constant, dissipation factor, dielectric strength, volume/surface resistivities, and thermal expansion, are measured on glass that has been formed into a bulk sample and annealed (heat treated) to relieve forming stresses. Properties such as density and refractive index are measured on both fibers and bulk samples, in annealed or un-annealed form ASTM C 693 is one of the test methods used for density determinations.

3. Resins Selection

In a FRP leaf spring, the Inter laminar shear strengths are controlled by the matrix system used. Since these are reinforcement fibers in the thickness direction fiber do not influences Inter Laminar Shear strength. Therefore, the matrix system should have good inter laminar shear strength characteristics compatibility to the selected reinforcement fiber. Epoxies show better inter laminar shear strength and good mechanical properties. Hence, epoxide is found to be the best resins that would suit this application. Different grades of epoxy resins and hardener combinations are classified, based on the mechanical properties.

Details of epoxy resin:

- CAS: 25068-38-6
- EC Number: 500-033-5
- Molecular Formula: C₁₈H₂₁ClO₃
- IUPAC Name: 4,4'-(2,2-Propanediyl)diphenol - 2-(chloromethyl)oxirane (1:1)
- Molar Weight [g/mol]: 320.810

B. Composition of Specimens

- Specimen A : Plain E-glass fiber specimen
-This specimen is of Plain E glass fiber
- Specimen B : E-glass fiber specimen (10% Al₂O₃ + 10% SiO₂)
-This specimen is of E-glass + 10% Al₂O₃ + 10% SiO₂.
- Specimen C: E-glass fiber specimen (20% Al₂O₃ + 10% SiO₂)
-This specimen is of E-glass + 20% Al₂O₃ + 10% SiO₂.

III. Design and Analytical Work

A. Design Workflow of Fiberglass Composites

In the manufacturing technique of E-Glass fiber leaf spring we use the traditional method for manufacture this product the work flow is shown in figure below. Before the actual manufacturing start we use wood pattern mould method is used to make amodel so that we can form the part as required shape. Glass fiber properties, such as tensile strength, Young's modulus, and chemical durability, are measured on the fibers directly. Other properties, such as dielectric constant, dissipation factor, dielectric strength, volume/surface resistivities, and thermal expansion, are measured on glass that has been formed into a bulk sample and annealed (heat treated) to relieve forming stresses. Properties such as density and refractive index are measured on both fibers and bulk samples, in annealed or un-annealed form. Density of glass fibers is measured and reported either as formed or as bulk annealed samples. ASTM C 693 is one of the test methods used for density determinations.

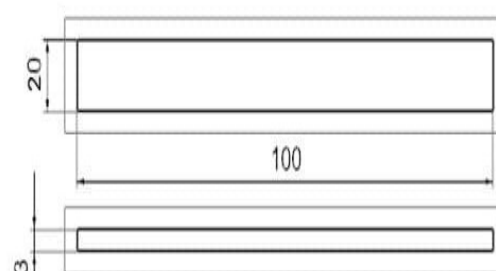
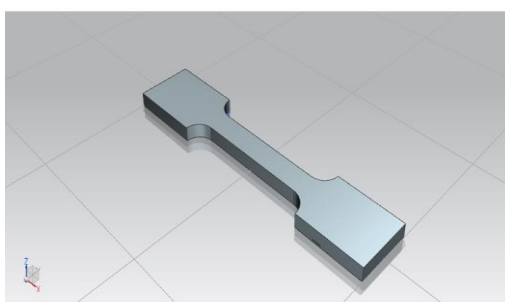
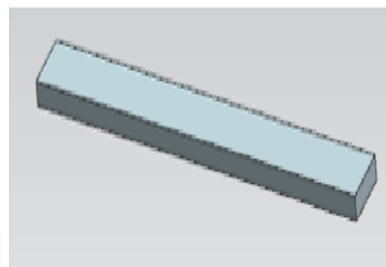
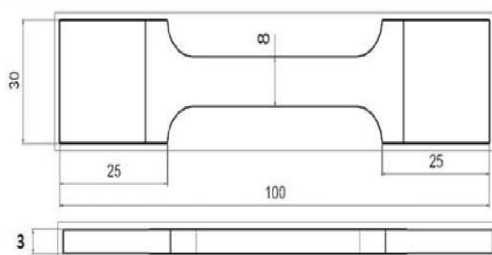

Fig. 3 Design of specimen for tensile testing.

Fig. 4 Design specimen for flexural testing

B. Analysis of Tensile and Flexure Specimen on ANSYS

Specimen	Analytical Breaking Load (kN)	ACP analysis Strain	Specimen	Analytical Breaking Load (kN)	ACP analysis deformation (mm)
Tensile Plain E-glass Specimen.	6.6	0.492	Flexure Plain E-glass Specimen.	3.95	5.691
Tensile E-glass + 10 % Al ₂ O ₃ + 10%SiO ₂ Specimen	11.6	0.431	Flexure E-glass + 10 % Al ₂ O ₃ + 10%SiO ₂ Specimen	4.2	5.092
Tensile E-glass + 20 % Al ₂ O ₃ + 10%SiO ₂ Specimen	14.9	0.401	Flexure E-glass + 20 % Al ₂ O ₃ + 10%SiO ₂ Specimen	4.6	4.7924

Table 1 ANSYS results of tensile specimen.

Table 2 ANSYS results of flexure specimen.

IV. MANUFACTURING OF COMPOSITE SPECIMENS

A. Procedure of Specimen Preparation

1. Specimen A: Plain E-glass fiber Steps:

- i. The specimen are cut to desired shape with help of 3-d printed template.
- ii. The ud-glass fibre is lined with adhesive tape on one side
- iii. E-xpoxy resin (80%) + hardner (20 %) coat is applied to the specimen sheet
- iv. Curing time of 35 to 40 minutes is allowed before application of second layer
- v. Second layer is added and procedure step 2 &3 are repeated to get desired thickness of sheet for specimen preparation.
- vi. Specimen assembly is placed under press load an allowed to cure for 24 hours.
- vii. The specimen are ground to desired shape.

2. Specimen B: E-glass + 10% Al₂O₃ + 10% SiO₂ Steps:

- i. The specimen are cut to desired shape with help of 3-d printed template
- ii. The ud-glass fibre is lined with adhesive tape on one side
- iii. Epoxy resin (80%) + hardner (20 %) coat is applied to the specimen sheet
- iv. 10 % Al₂O₃ + 10 % SiO₂ is added (half potion per layer)

Fig. 5 Al₂O₃ & SiO₂

- v. Curing time of 35 to 40 minutes is allowed before application of second layer
- vi. Second layer is added and procedure step 2 &3 are repeated to get desired thickness of sheet for specimen preparation.
- vii. Specimen assembly is placed under press load an allowed to cure for 24 hours.
- viii. The specimen are ground to desired shape

3. Specimen C: E-glass + 20% Al₂O₃ + 10% SiO₂ Steps:

- i. The specimen are cut to desired shape with help of 3-d printed template
- ii. The ud-glass fibre is lined with adhesive tape on one side
- iii. Epoxy resin (80%) + hardner (20 %) coat is applied to the specimen sheet
- iv. 20 % Al₂O₃ + 10 % SiO₂ is added (half potion per layer)
- v. Curing time of 35 to 40 minutes is allowed before application of second layer
- vi. Second layer is added and procedure step 2 &3 are repeated to get desired thickness of sheet for specimen preparation.
- vii. Specimen assembly is placed under press load an allowed to cure for 24 hours.
- viii. The specimen are ground to desired shape.

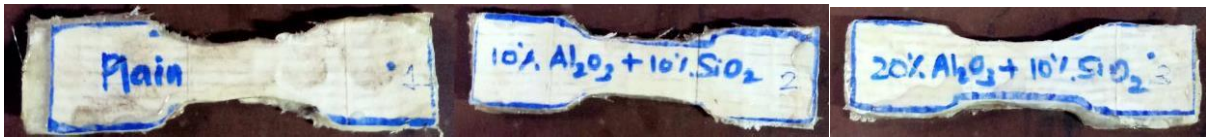

Fig. 6 Tensile test specimens A, B & C resp.



Fig. 7 Flexure test specimens A, B & C resp.

V. TESTING AND RESULTS OF SPECIMEN

A. Testing of Specimens

1. Tensile test on UTM

Consider the typical tensile specimen shown in Fig. 8. It has enlarged ends or shoulders for gripping. The important part of the specimen is the gage section. The cross-sectional area of the gage section is reduced relative to that of the remainder of the specimen so that deformation and failure will be localized in this region. The distances between the ends of the gage section and the shoulders should be great enough so that the larger ends do not constrain deformation within the gage section, and the gage length should be great relative to its diameter. Otherwise, the stress state will be more complex than simple tension.

Test Standard: ASTM D 5034

2. Flexural test on flexure strength testing machine

This method covers the breaking strength and elongation determined by the grab procedure. This method is applicable to woven, nonwoven and felted fabrics. It is not recommended for glass or knit fabrics. The grab method is a strength/elongation test in which the central part of the width of a specimen is gripped in the clamp.

Test Standard: ASTM D 790

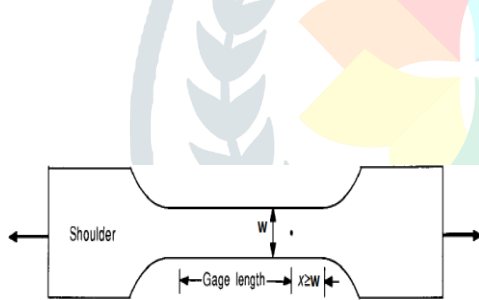

Fig. 8 Typical tensile test specimen.

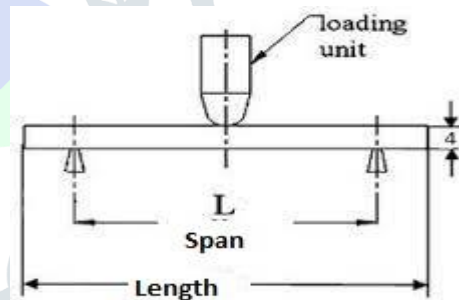

Fig. 9 Typical flexure test specimen.

B. Results of Specimen Testing

1. Results of Tensile Test

Specimen	Breaking Load (kN)	Specimen	Flexural Strength
Tensile Plain E-glass Specimen.	6.6	Flexure Plain E-glass Specimen.	32.26 MPa
Tensile E-glass + 10% Al ₂ O ₃ + 10%SiO ₂ Specimen.	11.6	Flexure E-glass + 10% Al ₂ O ₃ + 10%SiO ₂ Specimen.	61.58 MPa
Tensile E-glass + 20% Al ₂ O ₃ + 10%SiO ₂ Specimen.	14.9	Flexure E-glass + 20% Al ₂ O ₃ + 10%SiO ₂ Specimen.	13.24 MPa

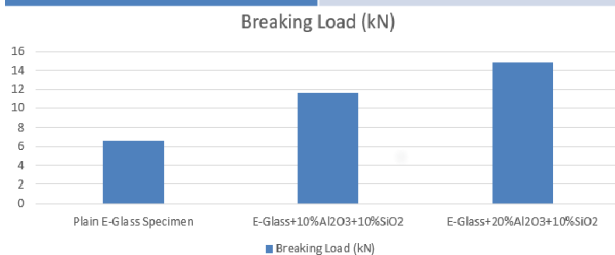

Fig. 10 Results of tensile test.

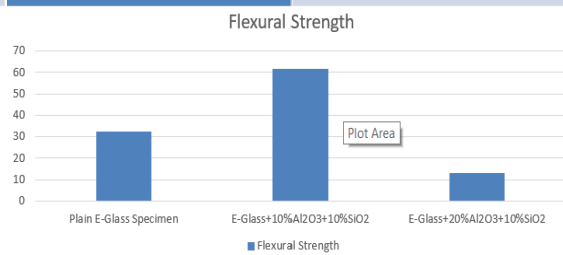

Fig. 11 Results of flexure test.

VI. CONCLUSION

- i. The E-glass fiber is a high quality glass, which is used as standard reinforcement fiber for all the present systems well complying with mechanical property requirements. Thus, E-glass fiber was found appropriate for this application and thus the tensile and flexure specimen have being prepared accordingly with varying composition of Al₂O₃ and SiO₂.
- ii. The design of the specimen geometry was done using CREO and the ACP analysis was done using ANSYS Workbench. The specimens were manufactured and tested using suitable methods, the results of same are in close agreement.
- iii. The flexural specimen with 10% Al₂O₃+10% SiO₂ were found to exhibit the highest Flexural Strength of 61.58 MPa.
- iv. The tensile specimen with 20% Al₂O₃+10% SiO₂ were found to exhibit the highest braking load of 14.9 KN.
- v. The results of the ACP analysis and theoretical analysis for both tensile and flexure specimen are in close agreement and thus the specimen design is validated.

ACKNOWLEDGMENT

The authors acknowledge the support for this work provided by the Pimpri Chinchwad College of Engineering & Research and the ELCA Quality Systems & Calibrations Pvt. Ltd. for their support throughout the research.

REFERENCES

- Rafiee R. On the mechanical performance of glass-fibre-reinforced thermosetting resin pipes: a review. *Compos Struct* 2016;143:151–64.
- Ma Y, Yan C, Xu H, Liu D, Shi P, Zhu Y, et al. Enhanced interfacial properties of carbon fiber reinforced polyamide 6 composites by grafting graphene oxide onto fiber surface. *Appl Surf Sci* 2018;452:286–98.
- Cuong Manh V, Thai Viet N, Liem Thanh N, Choi HJ. Fabrication of adduct filled glass fiber/epoxy resin laminate composites and their physical characteristics. *Polym Bull* 2016;73(5):1373–91.
- Wu Q, Zhao R, Liu Q, Jiao T, Zhu J, Wang F. Simultaneous improvement of interfacial strength and toughness between carbon fiber and epoxy by introducing amino functionalized ZrO₂ on fiber surface. *Mater Des* 2018;149:15–24.
- Zegaoui A, Derradji M, Ma R, Cai W-a, Medjahed A, Liu W-b, et al. Silane-modified carbon fibers reinforced cyanate ester/benzoxazine resin composites: morphological, mechanical and thermal degradation properties. *Vacuum* 2018; 150:12–23.
- A. Amaro, P. Reis, M. Neto, C. Louro, Effects of alkaline and acid solutions on glass/ epoxy composites, *Polym. Degrad. Stabil.* 98 (2013) 853–862.
- S.Y. Nayak, S.S. Heckadka, L.G. Thomas, A. Baby, Tensile and Flexural Properties of Chopped Strand E-Glass Fibre Mat Reinforced CNSL-Epoxy Composites, *MATEC Web of Conferences*, EDP Sciences, 2018, 02025.
- K. Imielinska, Environmental stress cracking in e-glass and aramid/glass epoxy composites, *Kompozyty (Composites)* 6 (2006) 4.
- N. Shuhaimen, N. Bonnia, A. Afina, M. Redzuan, M. Mohamed, Environmental Stress Cracking Resistance (ESCR) of Rubber-Toughened Polyester-Kenaf Composites under Active Environment, *Advanced Materials Research*, Trans Tech Publ, 2013, pp. 59–63.
- P.S. Rao, M.M. Hussain, Hydrothermal Ageing Effects on Flexural Properties of GFRP Composite Laminates, 2013.
- Chen Min-sun, Jiang Hou-man, Liu Ze-jin. Determination of thermal decomposition kinetic parameters of glassfiber/epoxy composite[J]. *High Power Laser and Particle Beams*, 2010, 22(9):1969-1972(in Chinese).
- Li Dong-mei, Guan Yi-sheng. Research on the tensile failure of notched unidirectional fiberglass[J]. *Journal of Mechanical Strength*, 2010, 32(5) : 781-784(in Chinese)
- Zhang Ying-jun, Zhu Xi, Mei Zhi-yuan, et al. Experimental study on natural aging of glass fiber reinforced plastic composites under marine environment[J]. *Journal of Huazhong University of Science and Technology (Natural Science Edition)*, 2011, 39(3):14-17(in Chinese)
- Liu Jian-xun, Zhu Jian-xun, Zu Qun. Study on preparation and properties of new high strength glass fibers[J]. *Journal of Functional Materials*, 2010, 41(7): 1290-1293(in Chinese)