

# Sustainable Environment in waste Management system on ODM using IOT

<sup>1</sup> R.Rakesh, <sup>2</sup>S.Rithik Rao, <sup>3</sup>M.G.Sunil Kumar

<sup>1,2,3</sup> VIII<sup>th</sup> Std, Bharathidhasanar Matriculation Higher Secondary School, Arakkonam

**Abstract :** Sustainable Environment from a change in perspective toward Internet of Things (IoT), investigates into IoT administrations have been led in an extensive variety of fields. The nonattendance of productive waste administration has caused genuine ecological issues and cost issues. Along these lines, in this proposed system, an IoT-based Outdoor air monitoring is proposed to diminish the measure of nourishment squander. Besides, the outdoor monitoring system incorporates different IoT strategies thinking about people comfort and expands the monitor the air. The examination demonstrated that the normal measure of sustenance waste could be examined and controlled. Benzene has been estimated all through the earth and is usually radiated in a few mechanical and transportation settings prompting across the board ecological and word related exposures. Discharges from waste disposal 0.005% and gas/petrochemical industry are its fundamental sources to the surrounding air, however a man's aggregate inward breath introduction can be raised from outflows from cigarettes, shopper items and gas fueled motors/apparatuses put away in carports joined to homes. While less dangerous solvents have been substituted for benzene, regardless it is a segment of oil based goods, including gas, and is a follow polluting influence in modern items bringing about proceeded with sub to low ppm word related exposures, however higher exposures exist in little, uncontrolled workshops in creating nations. Indoor air convergences of many ppb happen in microenvironments containing indoor sources mainly in homes and hospitals. Benzenes are creating cancer in human beings and also this can be easily monitored and controlled in outdoor and Indoor System using IOT by this proposed work.

## I. INTRODUCTION

The Internet of Things (IoT) is an idea in which encompassing items are associated through wired and remote systems without client intercession [4]. The term Internet of Things was presented by Kevin Ashton, who was the chief of the Auto-ID Centre of MIT in 1999. In the field of IoT, the articles impart and trade data to give progressed astute administrations to clients. The underlying specialized acknowledgment of IoT was accomplished by using RFID innovation for the recognizable proof and following of gadgets and putting away gadget data. For IoT applications playing out these capacities, an assortment of examines on IoT administrations including natural observing medicinal services and keen home innovation are being led [1]. Attributable to the ongoing advances in cell phones outfitted with different sensors and correspondence modules, together with correspondence arrange innovations, for example, Wi-Fi and LTE, the IoT has increased extensive scholarly interests. The current IoT performs detecting, activating, information assembling, putting away, and preparing by interfacing physical or virtual gadgets to the internet [5].

An aimless and unlawful release of waste, a nonappearance of waste transfer and administration frameworks, and wasteful waste administration strategies have caused genuine ecological issues and have brought about extensive expenses for waste transfer.

## II. Sustainable Environment

A state in which the requests set on nature can be met without decreasing its ability to enable all individuals to live well, now and in the future. Sustainable financial development while advancing occupations and more grounded economies. The majority of the abovementioned and progressively while handling the impacts of environmental change, contamination and other ecological components that can hurt and do hurt individuals' wellbeing, occupations and lives. Maintainability to incorporate soundness of the land, air and sea. The three logical standards of manageability are: (1) reliance on sun oriented vitality, (2) Biodiversity, and (3) concoction cycling. Sustainability is vital for some, reasons including: Environmental Quality – In request to have solid networks, we require clean air, normal assets, and a nontoxic domain. Development – UNTHSC's enlistment keeps on developing, so we require more assets, for example, vitality, water, and space.

Natural and supportability appraisals. Information territories: mechanical environment, financial examination and society. Natural and supportability evaluations are fortified through improvement of ICT-based demonstrating, computerized information accumulation, handling and spread. Natural manageability is the rates of inexhaustible asset collect, contamination creation, and non-sustainable asset consumption that can be proceeded inconclusively [3]. On the off chance that they can't be proceeded inconclusively then they are not sustainable. A economical city, or eco-city (additionally "ecocity") is a city outlined with thought of ecological effect, possessed by individuals committed to minimization of required contributions of vitality, water and nourishment, and waste yield of warmth, air contamination - CO<sub>2</sub>, methane, and water nonessential components of a supportable city

- 1) Access to open assets.
- 2) Urban reestablishment activities.
- 3) Reduction of CO<sub>2</sub> outflows.
- 4) Favouring moral utilization.
- 5) Reduce, reuse and recycle.

### III. Waste Management

While less dangerous solvents have been substituted for benzene, regardless it is a segment of oil based goods, including gas, and is a follow polluting influence in modern items bringing about proceeded with sub to low ppm word related exposures, however higher exposures exist in little, uncontrolled workshops in creating nations. Discharges from gas/petrochemical industry are its fundamental sources to the surrounding air, however a man's aggregate inward breath introduction can be raised from outflows from cigarettes, shopper items and gas fuelled motors/apparatuses put away in carports joined to homes. Air tests are gathered in canisters or on adsorbent with ensuing measurement by gas chromatography. Surrounding air fixations differ from sub-ppb run, low ppb, and several ppb in country/rural, urban, and source affected regions, separately. Here and now natural exposures of ppm happen amid vehicle energizing. Indoor air convergences of many ppb happen in microenvironments containing indoor sources. Word related and natural exposures have declined where controls restrain benzene in gas (<1%) and cigarette smoking has been restricted from open and work places. Comparable controls ought to be executed worldwide to decrease benzene introduction. The biomarker thinks about recommend benzene natural exposures are in the sub to low ppb extend however non-benzene hotspots for urinary metabolites, contrasts in metabolic rates contrasted with word related or creature dosages, and the nearness of polymorphisms should be viewed as while assessing dangers from ecological exposures to people or possibly helpless populaces.

### IV. Benzene in waste management

Benzene does not collect in creatures or plants. As a VOC, air-borne benzene can respond with other air contamination to frame ground levels ozone which can harm harvests and materials. It is anyway improbable that benzene has any natural impacts at a worldwide level. Benzene is a demonstrated carcinogen. IARC arranges benzene as "cancer-causing to people," in light of adequate proof that benzene causes intense myeloid leukemia (AML). IARC additionally takes note of that benzene presentation has been connected with intense lymphocytic leukaemia (ALL), ceaseless lymphocytic leukaemia (CLL), various myeloma, and non-Hodgkin lymphoma. It is discharged into the air by emitting volcanoes, from the smoke of woodland fires and, strangely, is likewise found in a few plants and creatures[2]. Benzene can rapidly dissipate into the air and be extended long separations. On the off chance that it is discharged into soil it can separate rapidly and may pollute groundwater. Benzene is shaped from both common procedures and human exercises. Regular wellsprings of benzene incorporate volcanoes and timberland fires. Benzene is additionally a characteristic piece of unrefined petroleum, fuel, and cigarette smoke. Benzene has a sweet, fragrant, gas like smell. Most people can start to smell benzene in air at 1.5 to 4.7 ppm. The scent edge by and large gives sufficient cautioning to intensely risky presentation fixations however is lacking for more interminable exposures. Smaller measures of benzene are utilized to make a few sorts of rubbers, oils, colours, cleansers, medications, explosives, and pesticides. Benzene is a generally utilized modern synthetic. Benzene is found in unrefined petroleum and is a noteworthy piece of gasoline. The Department of Health and Human Services has confirmed that benzene is a known cancer-causing agent (can cause tumour). Both the International Agency for Cancer Research and the EPA have discovered that benzene is cancer-causing to people. Introduction to benzene might be unsafe to the conceptive organs. Most of the metabolites of benzene leave the body in the pee inside 48 hours after exposure. The primary wellsprings of benzene are from vehicle deplete and other ignition forms and from industry creating or utilizing it. Benzene is additionally discharged normally from volcanoes and woodland fires, yet the sums discharged are inconsequential in contrast with those transmitted by man's activities. Benzene is a broadly utilized modern compound. Benzene is delivered normally by volcanoes and woodland fires.

#### Products Containing Benzene

- Paint, enamel, and varnish removers.
- Modern solvents.
- Gas and different powers.
- Pastes.
- Paints.
- Furniture wax.
- Cleansers.
- Thinners.

The six carbon molecules shape a superbly customary hexagon. The majority of the carbon-carbon bonds have the very same lengths - somewhere close to single and twofold bonds. There are delocalized electrons above and underneath the plane of the ring, which makes benzene especially steady.

## V. Benzene Properties

Benzene is a dreary fluid. Benzene is dissolvable in natural solvents however immiscible in water. It is a fragrant compound so it has an ordinary sweet-smelling scent. Benzene is profoundly inflammable and consumes with dingy fire.

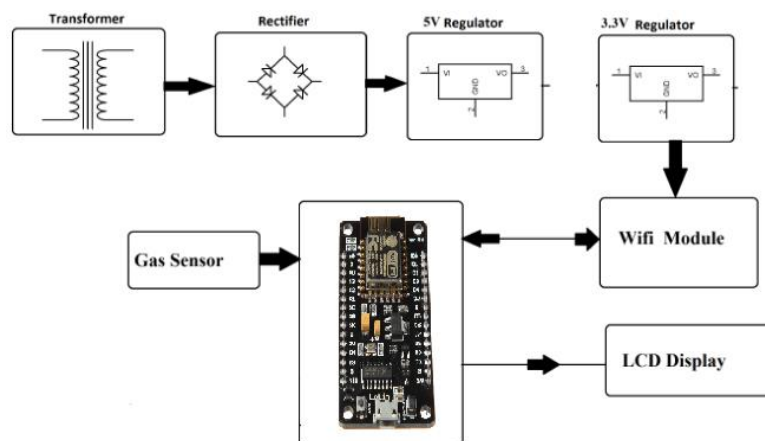

Fig.1. Architecture for the proposed system

Unsafe disposal, which might be in strong, fluid or vaporous shape, may make threat wellbeing or condition, either alone or when in contact with different squanders. Different offices have characterized risky squanders in various courses and thusly, there is no consistently acknowledged global definition up until now. It is assumed that around 10 to 15 percent of squanders delivered by enterprises are perilous and the age of risky squanders is expanding at the rate of 2 to 5 percent for each year.

## VI. Necessary to measure the benzene in Industrial Waste:

Introduction to benzene can happen in assembling, transport and utilization of benzene in the oil, concoction and petrochemical businesses. Introduction to this concoction might be essential or critical for restricted periods amid routine and non-routine activities (allude to your nearby administrative rules, organization, and hygienist). Benzene is a cancer-causing agent, which means it causes malignancy. Notwithstanding activating disease, introduction to this compound at high focuses in the 10,000 to 20,000 ppm range will result in passing.

At long last, Benzene is a presumed toxicant to various frameworks basic to life.

- Cardiovascular
- Endocrine
- Gastrointestinal
- Immunological
- Neurological
- Respiratory

Results from a National Occupational Exposure Survey that over 400,000 individuals who worked around Benzene. Benzene is positioned generally close to the highest priority on the rundown of around 12,000 introduction occasions. Consequently it is vital to avert introduction of workers to this compound through at least one of the pathways appeared in the realistic beneath. As appeared, Benzene has various passage courses into the body. A blend of administrative and expert offices or associations has set up introduction points of confinement to ensure labourers.

## VII. Expulsion of Benzene

Expulsion of benzene from a refinery waste air stream by water absorption and bio trickling filtration. Normal centralizations of the waste air stream entering the water scrubber were 10.61 mg Nm<sup>-3</sup> benzene Results demonstrate the advantages got from a blend of various evacuation advancements: water scrubbers to expel crest focuses and solvent mixes, and filter to expel mixes with lower dissolvability, because of the biodegradation performed by microorganisms. Resulting section through the BTF permitted a further decrease of normal fixations, which diminished to 2.10 mg Nm<sup>-3</sup> benzene, along this lines permitting generally speaking normal evacuation efficiencies of 80% benzene was removed.

Whenever benzene (C<sub>6</sub>H<sub>6</sub>) responds with oxygen, carbon dioxide and water are delivered. The fair condition for this response is:

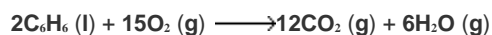

### VIII. Experimental analysis for the proposed system

The proposed setup clearly shows the monitoring and control of the benzene in the Industries mainly in petrochemical was carried out. The benzene sensor senses the C<sub>6</sub>H<sub>6</sub> and thus the signal is converter in to digital and the nodeMCU ESP8266 controller command the siren to indicate if the level of the benzene is increased or decreased in the air in the industries. When this benzene is increase the expulsion can be carried out by filtering or by sending the oxygen to the benzene thereby converting into carbon dioxide and water.

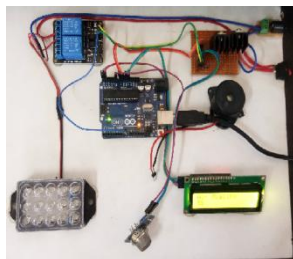

**Fig.2.Experimental setup for the proposed system**

### IX. Conclusion

Benzene exposures still regularly happen inside both indoor and outdoor settings, however they have been declining in the course of the most recent quite a few years. Word related exposures are presently ordinarily beneath the administrative standard of 1ppm and frequently underneath 0.1 ppm. In any case, recognizing higher exposures, surpassing 10's of ppm exist in little, unregulated work environments is an imperative information hole. Natural exposures among the all inclusive community are much lower than word related exposures, extending from <1 to 10 ppb with the essential ecological benzene sources being portable outflows and cigarette smoke. In this proposed system, a coordinated arrangement of Node MCU, sensors and LCD display using IOT is presented for proficient and monetary for the benzene formation in petrochemical Industries. The created system gives enhanced database to benzene gathering time furthermore, at every area of petrochemical industries. Using IOT mainly this system is easy to monitor and control the benzene in the outdoor air like petrochemical and leather industries. The advancements which are utilized in the proposed framework are adequate to guarantee the pragmatic what's more, ideal for monitor and control for providing the green condition to the workers and public.

### References

- [1]. Emily Gertz, Patrick Di Justo, "Environmental Monitoring with Arduino" Copyright © 2012 Emily Gertz and Patrick Di Justo. All rights reserved. Printed in the United States of America, ISBN: 978- 1-449-31056-1, January 20, 2012.
- [2]. WHO (2003). Benzene in drinking-water. Background document for development of WHO Guidelines for Drinking-water Quality. Geneva, World Health Organization (WHO/SDE/WSH/03.04/24)
- [3]. IARC (in preparation). A review of human carcinogens. F. Chemical agents and related occupations. Lyon, International Agency for Research on Cancer (IARC Monographs on the Evaluation of Carcinogenic Risks to Humans, Vol. 100) [summary in Baan R et al. (2009). A review of human carcinogens—Part F: Chemical agents and related occupations. The Lancet Oncology, 10(12):1143–1144
- [4]. HN Saha, A Mandal, S Abhirup, "Recent trends in the Internet of Things", 2017
- [5]. Sunilkumar S. Manvi, Gopal Kirshna Shyam, "Re-source management for IaaS in cloud computing: A Survey", Journal of Network and Computer Applications Elsevier, vol. 41, no. 1, pp. 424-440, 2014. CrossRef Google Scholar.