

Women's Security Jacket

¹Rama Gaikwad,²PranaliMahadik,

^{1,2}Assistant Professor,

^{1,2}Department of Computer Engineering,

^{1,2}Anantrao Pawar College of Engineering & Research, Pune, India.

Abstract :It is a well known fact that women's empowerment is the key for the world development. Now a day's women's are facing more troubles physically in countries like India. The main reason for this type of troubles is the lack of safety for women from the government. But can't provide safety to every woman. It can only provide some safety measures. It is the duty of every woman to prevent them. But they are not physically stronger than men. Hence additional equipments are needed for the women to protect themselves. The main aim of our project is to design a security system which is a wearable jacket. It has a control button that will be used by women to inform her parents and nearby police station when they are in distress. This jacket directly gets connected to the satellite through GPS when activated. Then the location is transferred through the GSM, it also contains a shock mechanism to produce non-lethal electric shock in emergency situations to deter the attacker

IndexTerms - Women safety, Automated SMS, electric shock, GPS, GSM, pressure sensor, panic switch.

I. INTRODUCTION

India is a country of peace-loving and law-abiding citizens. It is a safe destination for domestic and international tourists. However, like any other civil society, there are aberrations, and a few persons break the law now and then. In recent past, a few isolated incidents have been reported in India in which women travellers were sexually assaulted. There have been many cases where cab drivers, taxi drivers or auto rickshaw drivers have harassed, molested or tried to kidnap the women passengers. Many women are afraid to be alone in public places due to fear of being harmed. This fear has been caused by repeated cases of violence towards women. Women's empowerment in the country can be brought once their safety and security is ensure, either it may be at home, public places or during travelling. Many attempts are made to make women journey safer. This paper presents design and implementation of women safety system which will ensure women safety during travelling in public transport vehicles such as cabs, taxi, bus and auto rickshaw.

II. Existing System

Survey shows 10 best mobile applications which ensure safety in case of emergencies listed below:

- A) FIGHT BACK: ,the women safety application, sends SOS alerts from your phone. Fight back uses GPS, SMS, location maps, GPRS, email and your Face bookaccount to inform your loved ones in case you are in danger.
- B) GUARDLY: This application places phone calls to the predefined contacts along with the name, real time location, type of emergencies and enables to identify different locations.
- C) ON WATCH: This application is developed especially for college students. It allows the user to easily alert friends and emergency responders and police when needed with the GPS location.
- D) FAMILY LOCATOR: This application notifies about the near and dear ones about the trouble. It provides the useful information about the criminals in the neighbourhood, tracking the most visited locations and so on. It also keeps connected with the family members with the support of GPS. It informs others about the exact location through messages, calls, emails with the press of a button.
- E) SENTINEL: It is a smartphone application used to serve as a virtual security guard for women. The users can press a button once they feel they are being stalked or harassed. It sends out instant alerts to let friends, family or police know about the trouble and save them.
- F) STREET SAFE: This application has a feature called "WALK WITH ME" which gets the details of the situation and stays on line until they ensure the users gets back home safe. In case the call is cut, the safety advisor connects the user to the local police for further help and guidance. In case of emergency situations, a feature called "SILENT ALARM" enables to get local help from the real time location using the GPS and the physical description of the user.
- G) CIRCLE OF 6: This application intends to add 6 members to your circle which is developed for college students which lets 6 friends know when you are facing a troublesome situations. With two taps, the app sends one out of three predetermined alert messages to six contacts of your choice including a call for help connecting home that automatically includes the real-time location. The app also consists of pre-programmed hotline numbers and a local number that can be customized for police or 911.
- H) B SAFE: The b Safe app works as a guardian that sends an emergency message to the chosen contacts with a push of a single button and its slogan is "Never walk alone". This application offers two levels of safety; a Risk mode with real time GPS which tracks the position and a Timer mode with an automatic alarm activation. It's a user-friendly app which just needs a single tap to inform the chosen contacts.
- I) CAB 4 ME: Cab4me, as the name suggests, is a mobile cab finder app that helps get a cab anywhere at any time. It works based on the location. The phone's GPS shows the location on the map and one can choose the pickup destination or a nearby taxi stand based on the available stand. If in case the database has no cab company for the specific area, a local web search is performed to get a result.
- J) HOLLABACK: " Hollaback ! You have the power to end street harassment", is the tag line of this particular app. Here the users can take a photo of the harasser and upload it as „caught in the act“ and submit their story on ihollaback.org. It signals the perpetrator that his photo is shared on the website as well as warns others from doing this act. The app encourages users to submit stories along with photographs of street harassment at every level from catcalls to strangers groping hands or even individuals exposing themselves in public roads.

III. PROPOSED SYSTEM

The present and proposed work explains about an innovative idea for women security which has become mandatory now –a-days. In this system, women wearing a jacket on her body is embedded with some modules like microcontroller (AT89S52), pressure sensor, GSM/GPS modules, panic switch ,etc. When the threshold of the pressure sensor crosses, the device will get activated as soon as the victim turns on the panic switch and immediately the location of the victim will be sent and tracked with the help of GPS. With the help of GSM emergency messages will be also sent to the registered contacts and one to police control room also the location of the victim will be updated after every ten minutes. The system is also capable to generate an electric shock to harm the attacker which may help the victim to escape.

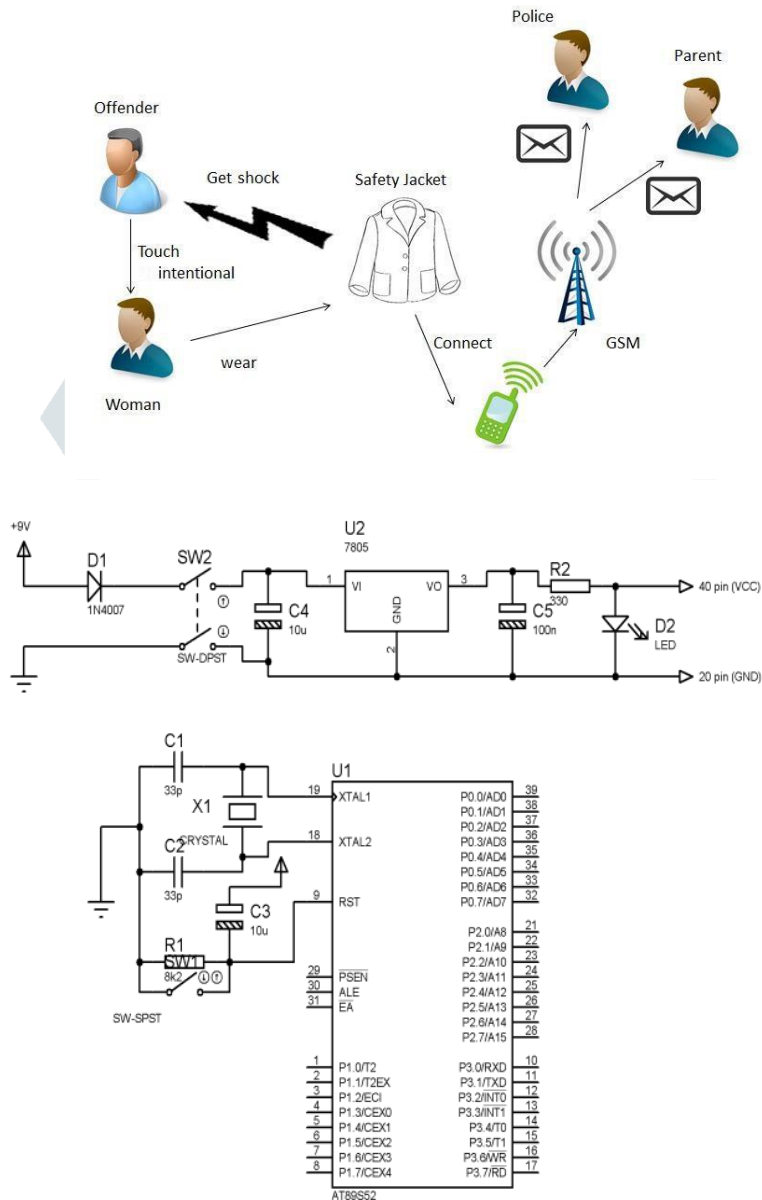

Figure 1: Architecture diagram.

Sr no.	Abbreviation	Component	Value	COST
1	D1	DIODE	1N4007	1
2	SW1	SWITCH	-	6
3	C1,C5	CAPACITOR	10Uf	2
4	C2	CAPACITOR	100uF	2
5	C3,C4	CAPACITOR	33Pf	2
6	X1	CRYSTAL	11.0592MHz	12
7	RT1	REGULATOR	7805	15
8	IC1	40 PINS SOCKET(89S52)	-	20
9	L1	LED	3mm	1
10	R1	RESISTOR	270Ω	1
11	R5	RESISTOR	8.2KΩ	1
12	RST1	RESET SWITCH	-	
13	B1	BUG STRIP	-	
14	89S52	MICROCONTROLLER	-	135
15	89V51RD2	MICROCONTROLLER	-	195

Figure 2: Component List

IV. EQUATIONS

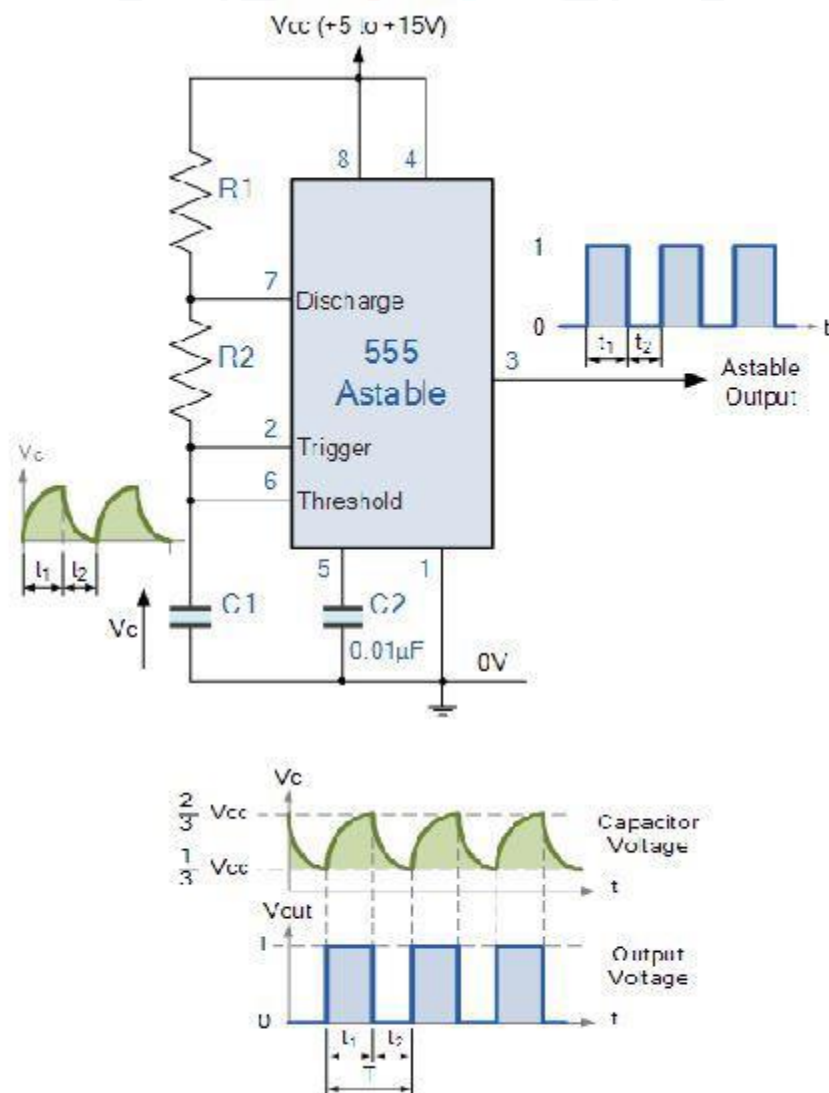

Figure 3: Basic Oscillator Circuit

In the 555 Oscillator circuit above, pin 2 and pin 6 are connected together allowing the circuit to re-trigger itself on each and every cycle allowing it to operate as a free running oscillator. During each cycle capacitor, C charges up through both timing resistors, R1 and R2 but discharges itself only through resistor, R2 as the other side of R2 is connected to the discharge terminal, pin 7. Then the capacitor charges up to $\frac{2}{3}V_{cc}$ (the upper comparator limit) which is determined by the $0.693(R_1+R_2)C$ combination and discharges itself down to $\frac{1}{3}V_{cc}$ (the lower comparator limit) determined by the $0.693(R_2.C)$ combination. This results in an output waveform whose voltage level is approximately equal to $V_{cc} \approx 1.5V$ and whose output ON and OFF time periods are determined by the capacitor and resistors combinations. The individual times required to complete one charge and discharge cycle of the output is therefore given as:

Astable 555 Oscillator Charge and Discharge Times

$$t_1 = 0.693(R_1 + R_2).C$$

and

$$t_2 = 0.693 \times R_2 \times C$$

Where, R is in Ω 's and C in Farads.

When connected as an astable multivibrator, the output from the 555 Oscillator will continue indefinitely charging and discharging between $\frac{2}{3}V_{cc}$ and $\frac{1}{3}V_{cc}$ until the power supply is removed. As with the monostable multivibrator these charge and discharge times and therefore the frequency are independent on the supply voltage. The duration of one full timing cycle is therefore equal to the sum of the two individual times that the capacitor charges and discharges added together and is given as:

555 Oscillator Cycle Time

$$T = t_1 + t_2 = 0.693(R_1 + 2R_2).C$$

The output frequency of oscillations can be found by inverting the equation above for the total cycle time giving a final equation for the output frequency of an Astable 555 Oscillator as

555 Oscillator Frequency Equation

$$f = \frac{1}{T} = \frac{1.44}{(R_1 + 2R_2).C}$$

By altering the time constant of just one of the RC combinations, the Duty Cycle better known as the mark to space ratio of the output waveform can be accurately set and is given as the ratio of resistor R2 to resistor R1. The Duty Cycle for the 555 Oscillator, which is the ratio of the ON time divided by the OFF time is given by:

$$\text{Duty Cycle} = \frac{T_{ON}}{T_{OFF} + T_{ON}} = \frac{R_1 + R_2}{(R_1 + 2R_2)} \%$$

The duty cycle has no units as it is a ratio but can be expressed as a percentage (%). If both timing resistors, R1 and R2 are equal in value, then the output duty cycle will be 2:1 that is, 66% ON time and 33% OFF time with respect to the period.

V. ADVANTAGES

This system can overcome the fear that scares every woman about her safety and security.

- Cost effective as it is controller based.
- Low power consumption.
- Small in size.
- Different modules used for security purpose are easily available and are not so expensive.
- Even if the GSM and GPS system does not catch the network the other two modules i.e. electric shock and buzzer will still help the victim to rescue.

VI. LIMITATIONS

- GPS and GSM reliability: The GPS and GSM system are not reliable. These modules suffer problems during overcast, also the GPS is unable to initialize quickly when kept under extreme indoors. However if the GPS system locates the location sometimes the GSM module does not have coverage and hence the messages are not sent to the stored contacts.
- Battery consumption and weight: The modules used in the system need 12V supply which makes the battery heavy also we require high mAh battery to keep system working for longer time. This can be avoided simply by using LiPo battery which solves the weight problem but increases cost of system.
- Mobile Network: The system sends emergency message to stored contacts but however it would not be helpful if the receiver mobile is out of coverage area.

VII. CONCLUSION

In this paper we have described a device, a security jacket for the safety of women. This application helps in providing security for women by providing an electric shock to the suspect. This security system allows immediate response in case of any harassment by sending alert message to registered number with location to prevent unfortunate incidents. The proposed design will deal with critical issues faced by women in the recent past and will help solve them through technologically sound gadgets. With further research and innovation, this project can be implemented in different areas of security and surveillance. The system can perform the real time monitoring of desired area and detect the violence with a good accuracy. Thus, this application can help the women in a big way from unsafe conditions.

VIII. REFERENCES

- [1]. Report of the Fourth World Conference on Women. New York, United Nations, 1995 (A/CONF.177/20/Rev.1) (<http://www.un.org/womenwatch/confer/beijing/reports/>, accessed 1 April 2013).
- [2]. World Health Organization, "Global and regional estimates of violence against women: prevalence and health effects of intimate partner violence and non-partner sexual violence, Geneva: World Health Organization (2013).
- [3] "Real time location systems", clarinox .Retreived 2010-08-04.
- [4] Bhaskar Kamal Baishya, —Mobile Phone Embedded With Medical and Security Applications||, , e-ISSN: 2278-0661 p-ISSN: 2278-8727 IOSR Journal of Computer Engg (IOSR-JCE) www.iosrjournals.org, Volume 16, Issue 3 (Version IX), PP 30-3, May-Jun. 2014
- [5] Nishant Bhardwaj and Nitish Aggarwal, —Design and Development of —Suraksha||-A Women Safety Device||, ISSN 0974-2239 International Journal of Information & Computation Technology online available at <http://www.irphouse.com>, Volume 4, pp. 787-792, November 2014.
- [6] R. George, A. Cherian., A. Antony, H. Sebastian, M. Antony, B.T. Rosemary "An Intelligent Security System for Violence against Women in Public Places", International Journal of Engineering and Advanced Technology (IJEAT) ISSN: 2249 – 8958, Volume-3, Issue-4, April 2014.
- [7] Palve Pramod, "GPS Based Advanced Soldier Tracking With Emergency Messages & Communication System," International Journal of Advance Research in Computer Science and Management Studies Research Article, Volume 2, Issue 6, June 2014.
- [8] J. Whipple, W. Arensman, M. S. Boler, A public safety application of GPS-enabled smartphones and the Android Operating System, IEEE International Conference on Systems, Man, and Cybernetics 2009, 11-14 Oct. 2009, pp. 2059-2061.
- [9] "Using wearable technology to answer women's safety" by Tuman Poddar, Ritesh C, Nagaraja B-harath Department Of Telecommunication Engineering, Cmr Institute Of Technology, International Journal of Science, Technology & Management Vol-ume No.04, Issue No. 05, May 2015
- [10] <http://www.engineersgarage.com/contribution/how-to-interface-GSM-SIM-300-modem-with-atmega32-to-send-and-receive-SMS>