

Renewable Energy as a FACTS device

¹Kanunje Meghana

¹Assistant professor

¹Electrical Engineering Department,

¹Anantrao Pawar College of Engineering, Parvati,Pune,India.

Abstract : The demand by load side results poor voltage regulation, poor voltage stability and reduced power transfer limits are observed. Therefore reactive power compensation is necessary, this is achieved by PV solar controller as a STATCOM, which is used to improve the stability and power transfer limits by improving load side power factor (Hence the reactive power), which further minimizes additional cost of.

IndexTerms - reactive power, STATCOM, PV solar controller

I. INTRODUCTION

The reactive power flow in electrical system causes the power factor reduction hence the large size conductor is required to transmit the same power as compared to conductor operating at high power factor. This causes voltage drop at the load side, which further results poor voltage regulation. The reactive power in system directly affects KVA rating of the equipment carrying the reactive power and hence affects the size and cost of the equipment directly. In an AC electrical power system, most of the loads are inductive loads absorbing reactive power and resulting in low lagging power factor. To order to minimize this effect of reactive power flow, nowadays FACT devices are preferred, which involves shunt compensation and Series compensation. In both cases, the line reactive power can be effectively controlled and thereby improving the performance of the overall electric power system. But this requires additional expenditure, which would raise the overall system cost.

1.1 Different sources of Renewable Energy

1.1.1 Wind power

Wind turbines can be used to harness the energy available in airflows. Current day turbines range from around 600 kW to 5 MW of rated power. Since the power output is a function of the cube of the wind speed, it increases rapidly with an increase in available wind velocity.

1.1.2 Solar power

Solar energy can be utilized in two major ways. Firstly, the captured heat can be used as solar thermal energy, with applications in space heating. Another alternative is the conversion of incident solar radiation to electrical energy, which is the most usable form of energy. This can be achieved with the help of solar photovoltaic cells or with concentrating solar power plants. Solar plants ranges from several watts to mega watts. It is non - polluting, reliable and can produce energy anywhere that there is sun shining, so its resources are not going to run out anytime. As the solar panel efficiency is just about 15 to 25 % but this parameter is neglected, because sun energy is available free of cost.

1.1.3 Small hydropower

Hydropower installations up to 10MW are considered as small hydropower and counted as renewable energy sources. These involve converting the potential energy of water stored in dams into usable electrical energy through the use of water turbines. Runof-the-river hydroelectricity aims to utilize the kinetic energy of water without the need of building reservoirs or dams.

1.1.4 Biomass

Plants capture the energy of the sun through the process of photosynthesis. On combustion, these plants release the trapped energy. This way, biomass works as a natural battery to store the sun's energy and yield it on requirement.

1.1.5 Geothermal

Geothermal energy is the thermal energy which is generated and stored within the layers of the Earth. The gradient thus developed gives rise to a continuous conduction of heat from the core to the surface of the earth. This gradient can be utilized to heat water to produce superheated steam and use it to run steam turbines to generate electricity. The main disadvantage of geothermal energy is that it is usually limited to regions near tectonic plate boundaries, though recent advancements have led to the propagation of this technology.

1.2 Renewable Energy in India: Progress, Vision and Strategy:

India's need to increase energy provision for its population and fast growing economy poses a challenge which is perceived as both a great opportunity as well as a necessity for the country to increase the share of renewable in the overall energy mix. At the same time there is a need to provide energy access to rural areas and reduce import dependence on fossil fuels. India's approach is to meet its energy needs in a responsible, sustainable and eco-friendly manner. As it does not pollute and eco friendly as far as global warming and environment part as concerned and freely available, therefore attracts to install and generates maximum power as possible. The central and state government provides subsidies on it.

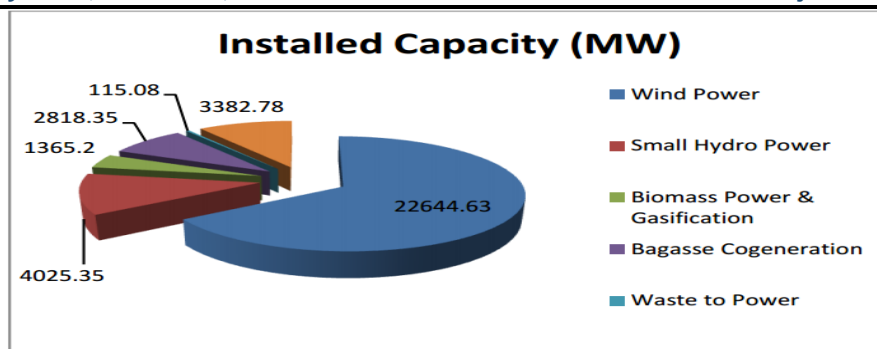

FIG. 1- RENEWABLE ENERGY SOURCES –INSTALLED CAPACITY

II. BLOCK DIAGRAM FOR SOLAR CONTROLLER AS STATCOM

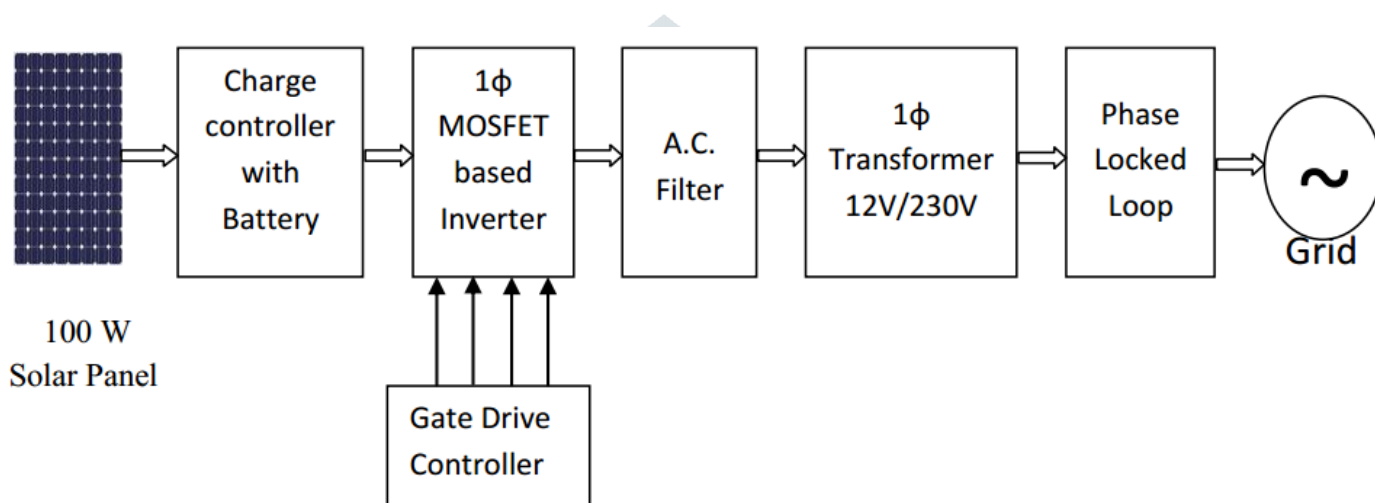

FIG. 2- BLOCK DIAGRAM FOR SOLAR CONTROLLER AS STATCOM

2.1 PV Solar controller as a STATCOM

PV Solar farms are equipped with grid tied inverters to facilitate the transfer of DC power generated from photovoltaic modules to the power grid. These inverters consist of voltage sourced converters with sinusoidal pulse width modulated (SPWM) switching and necessary filter and/or interconnection transformer between the converter and the grid. PV solar farms are absolutely idle in the nighttime and only partially utilized during early morning and late evening hours. The PV-STATCOM can provide dynamic reactive power compensation utilizing the entire inverter capacity during nighttime and the inverter capacity remaining after real power generation during daytime.

2.2 Battery with charge controller

A 12 volt, 10Ah battery is selected to work as a source at night time and transient power source during day time. The charge controller matches the PV Solar module voltage and battery voltage for smooth and safe battery charging.

2.3 PV Solar module

A 100 watt PV Solar module produces its rated dc power under a sunny day condition, which has a terminal voltage of 18 volt with maximum current delivery of 6 ampere at full load. The real power generation made by the PV Solar module is affected as the sun radiation changes.

2.4 Inverter Transformer

PV inverters uses inverter transformer (12-0-12 / 230V) to convert DC to AC along with the MOSFET's, which also matches the voltage on AC grid side. It also helps to maintain electrical isolation between the PV system and the grid.

III. Analysis of Total Harmonic Distortion, Voltage, Current

3.1 Analysis of Total Harmonic Distortion (THD)

The third and fifth order harmonics are observed and analyzed by the power analyzer. And it is to be noted that, third order harmonic for voltage is 1% and that of fifth order is 2.4%. The Total Harmonic Distortion (THD) is 4%. Similarly for the current THD is analyzed and found zero. The change in current for with and without PV solar controller as a STATCOM also shows that the compensation is made. The supply current with compensation is less than without compensation, which further minimizes losses and increases power handling capability.

3.2 Analysis voltage and current

The voltage without compensation contains harmonic due to reactive power demand, which distorts the fundamental sine wave. After injecting real and reactive power by PV solar controller as a STATCOM to grid, most of the harmonic order like seventh onwards is get compensated and the voltage wave appears closer to fundamental sine wave with 2 % third and fifth harmonic in it.

IV. Application of PV solar controller as a STATCOM

1. Both side real and Reactive power flow: The controller with inverter can generate and absorb reactive power so that it can be used to compensate reactive power at load side and improve the power factor of system during night time. Also injects real power, when load demand increases during day time.
2. Voltage regulation: PV solar controller as a STATCOM can be used to improve the voltage regulation in order to increase the power handling capability. Thus maintains the system voltage within its limit.
3. Minimizing harmonics: Due to voltage source inverter with capacitor, the reactive power compensation can be used for the filtering out the load harmonic current in order to form a nearly sinusoidal supply current.
4. Power factor improvement: Reactive power compensation of load can be done by PV solar controller as a STATCOM, which further improves system power factor nearly to unity.

V. RESULTS AND DISCUSSION

5.1 Results

The power factor noted before compensation is in the range between 0.35 to 0.77 with respect to different load. While on the other hand power factor after compensation is between 0.82 to 0.99 which is a improvement after the reactive power compensation.

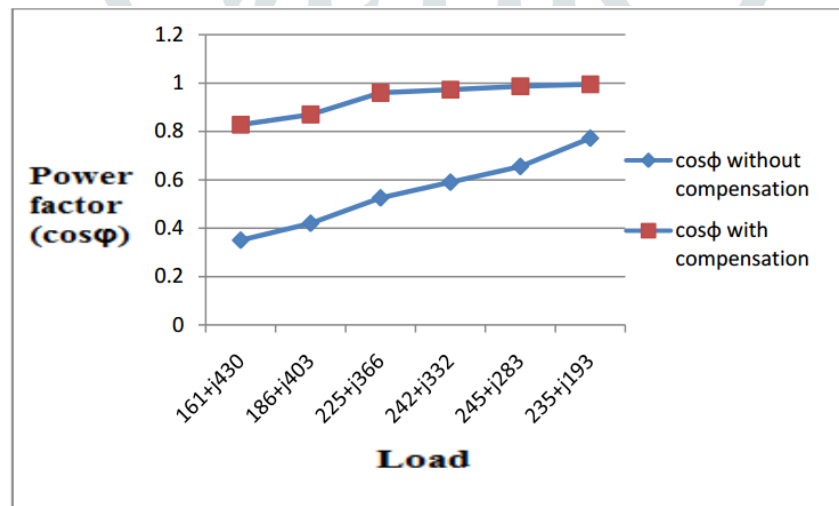

FIG.3- POWER FACTOR IMPROVEMENT USING COMPENSATOR

VI. ACKNOWLEDGMENT

The reactive power demand by load side results poor voltage regulation, poor voltage stability and reduced power transfer limits are observed. Therefore reactive power compensation is necessary, this is achieved by PV solar controller as a STATCOM, which is used to improve the stability and power transfer limits by improving load side power factor (Hence the reactive power), which further minimizes additional cost of STATCOM.

VII. REFERENCES

- [1] Rajiv K. Varma, Vinod Khadkikar, and Ravi Seethapathy, "Nighttime application of PV solar farm as a STATCOM to regulate grid voltage", IEEE Trans. On Energy Conversion, vol. 24, no. 4 Dec. 2009.
2. Rajiv K. Varma, Shriram S. Rangarajan, Iurie Axente and Vinay Sharma, —Novel application of a PV Solar Plant as a STATCOM during Night and Day in a distribution Utility Network, Power system conference and Exposition(PSCE), 2011 IEEE.
3. Rajiv K. Varma and Vinod Khadkikar, —Utilization of Solar Farm Inverter as STATCOM, US Provisional Patent application filed 15 Sept. 2009
4. Rajiv K. Varma, Shah Arifur Rahman and Ravi Seethapathy, "Novel Control of Grid connected Photovoltaic Solar Farm for improving transient stability and transmission limits both during Night and Day".
5. R. M. Mathur and R. K. Varma Thyristor Based FACTS controllers for electrical transmission system, New York: Wiley-IEEE press, 2001
6. N. G. Hingorani and L. Gyugyi, Understanding FACTS, IEEE Press, 1996. ISBN:978-81-265-3040-3
7. S. B. Kjaer, J. K. Pederson, and F. Blaabjerg, —A review of single-phase grid connected inverters for photovoltaic modules, IEEE Trans. Ind. Appl., vol. 41, no. 5, pp. 1292–1306, Sep. 2005.
8. Mohammad H. Rashid, Power Electronics-Circuit devices and applications, 3rd edition, Pearson, ISBN 978-81-317-0246-8, 2009, INDIA.

9. Sachin Jain and Vivek Agarwal, —A Single Stage Grid Connected Inverter Topology For Solar PV systems With Maximum Power Point Tracking, IEEE Transaction on Power Electronics, Vol.22, No.5, September 2007.
10. Adil Sarwar, Mohammad S. J. Asghar, —Simulation and Analysis of a Multilevel Converter Topology for Solar PV Based Grid Connected Inverter, Smart Grid and Design of PV Solar controller as a STATCOM in a distribution utility network Department of Electrical Engg. 54 Government College of Engineering, Karad Renewable Energy, 2011, 2, 56-62 doi:10.4236/sgre.2011.21007 Published Online February 2011.
11. Hinz, H.; Mutschler, P. —Voltage Source Inverters for Grid Connected Photovoltaic Systems, Darmstadt University of Technology, Institute for Power Electronics and Drives.
12. T. J. Miller, —Reactive power Control in Electric Systems, John Wiley & Sons, 1982.
13. Dixon, L. Moran, J. Rodriguez, R. Domke, "Reactive Power Compensation Technologies: State-of-the-Art Review", IEEE/JPROC, Vol.93, No.2, pp.2144-2164, Dec. 2005.
14. Ahmed, M.R. ; Electr. & Electron. Eng. Dept., Dhaka Univ. of Eng. & Technol., Gazipur ; Alam, M.J. Power factor improvement by pulse width modulated switched single capacitor, Power Electronics, 2006. IICPE 2006. India International Conference on 19-21 Dec. 2006, Chennai, IEEE
15. M. Calais, J. Myrzik, T. Spooner, and V. G. Agelidis, —Inverters for single phase grid connected photovoltaic systems—An overview, in Proc. IEEE PESC, Jun. 23–27, 2002, vol. 4, pp. 1995–2000.
16. Mohamed A. Eltawil , Zhengming Zhao, —Grid-connected photovoltaic power systems: Technical and potential problems—A review, Contents lists available at Science Direct Renewable and Sustainable Energy Reviews 14 (2010) 112-129.
17. Zheng Zhao, —High Efficiency Single-stage Grid-tied PV Inverter for Renewable Energy System, Bradley Department of Electrical and Computer Engineering. The Virginia Polytechnic Institute and State University April , 2012 Blacksburg, VA.
18. S.K.Parida, R.K.Behera and G.Saikrishna— Hardware Implementaion of 10w PV Panel as STATCOM Voltage Compensation in a Daytime Distribution Utility. IEEE press, 2015. ISBN: 978-1-4799-1823-2.

