

Channel Estimation in OFDM Mobile Wireless Channel Using Least Square Method

¹Nidhi Jaiswal, ²Richa Shrivastava, ³Shivam Khare

¹Mtech 4th Sem (Communication System), ^{2,3}Assistant Professor
Electronic and Communication Department
VITS, Jabalpur, India

Abstract - Error free transmission is one of the main aims in wireless communications. With the increase in multimedia application, large amount of data is being transmitted over wireless communications. Due to the channel fading and the Doppler shifts caused by user mobility, a common problem in wireless systems, additional technologies are needed to combat multipath propagation fading and Doppler shifts. Time-variant channel estimation is one such crucial technique used to improve the performance of the modern wireless systems with Doppler spread and multipath spread. Channel estimation is done by estimating the time-varying channel frequency response for the OFDM symbols. . The Least Square (LS) method is used for channel estimation technique using the block type pilot sequences. Time-variant channel estimation using pilot Sequences technique is a useful channel estimation technique in mobile wireless communication for accurately estimating transmitted information. The main advantage of pilot sequence is allowing more accurate representation of high mobility mobile wireless channels with low complexity. The main goal is to test the recently proposed method, time-variant channel estimation using pilot sequence.

Keywords - Doppler Diversity, OFDM, Pilot Sequences, Channel estimation, Least Square.

I. INTRODUCTION

Channel estimation is an important technique especially in mobile wireless network systems where the wireless channel changes over time, usually caused by transmitter and/or receiver being in motion at vehicular speed. Mobile wireless communication is adversely affected by the multipath interference resulting from reflections from surroundings, such as hills, buildings and other obstacles. In order to provide reliability and high data rates at the receiver, the system needs an accurate estimate of the time-varying channel. Furthermore, mobile wireless systems are one of the main technologies which used to provide services such as data communication, voice, and video with quality of service (QoS) for both mobile users and nomadic. The knowledge of the impulse response of mobile wireless propagation channels in the estimator is an aid in acquiring important information for testing, designing or planning wireless communication systems.

Channel estimation is based on the training sequence of bits and which is unique for a certain transmitter and which is repeated in every transmitted burst [3]. The channel estimator gives the knowledge on the channel impulse response (CIR) to the detector and it estimates separately the CIR for each burst by exploiting transmitted bits and corresponding received bits. Signal detectors must have knowledge concerning the channel impulse response (CIR) of the radio link with known transmitted sequences, which can be done by a separate channel estimator. The channel estimator is shown in fig 1.

The channel estimation method based on OFDM technique. Orthogonal frequency division multiplexing can accommodate high data rate in the mobile wireless systems in order to handle multimedia services. It is important to understand the OFDM technology because the channel estimation is an integral part of OFDM system.

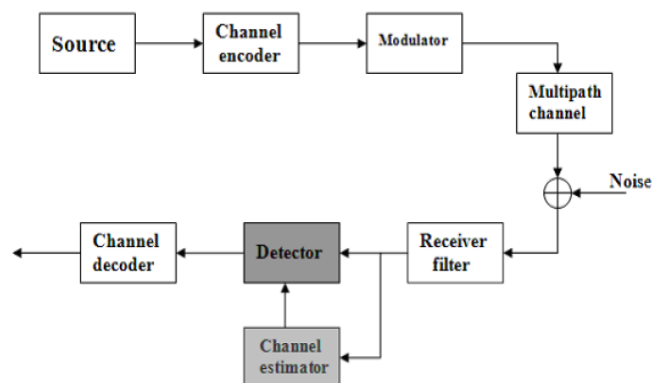

Figure 1. The block diagram of the channel estimator

OFDM technology can be used effectively to avoid the effect of frequency-selective fading and narrowband interference from parallel closely spaced frequencies in mobile networks. One of the desirable features of OFDM is its robustness to the multipath induced intersymbol interference. On the other hand due to the frequency selective fading of the dispersive wireless channel, some

sub channels may face deep fades and degrade the overall system performance. In order to compensate the frequency selectivity, techniques such as error correcting code and diversity have to be used [4]-[6].

Doppler shift is caused by the relative motion between the transmitter and receiver. It is considered as Doppler shift in the environment of single-path while Doppler spread in the environment of multipath. For OFDM system, the orthogonality between subcarriers is destroyed by Doppler spread. The greater the relative motion is the stronger the orthogonality is destroyed. Doppler Spread cannot ignore in the scenario [7]. So it is increasingly important to solve the Doppler frequency-spread in high-mobility environment.

II. ORTHOGONAL FREQUENCY DIVISION MULTIPLEXING (OFDM)

Orthogonal frequency division multiplexing can accommodate high data rate in the mobile wireless systems in order to handle multimedia services. It is important to understand the OFDM technology because the channel estimation is an integral part of OFDM system. OFDM technology can be used effectively to avoid the effect of frequency-selective fading and narrowband interference from parallel closely spaced frequencies in mobile networks. If there is no orthogonality in the channel, inter-channel interference (ICI) can be experienced. With these vital advantages, OFDM technology has been widely used by many wireless standards such as WLAN, WMAN, and DVB [8]. In OFDM scheme, complex filters are not required and time-spreading can be used without any complications in OFDM scheme.

Orthogonal Frequency Division Multiplexing (OFDM) is one of the promising applications, which reduces the multipath fading and makes complex equalizers unnecessary [9]. The concept of using parallel-data transmission and frequency division multiplexing (FDM) was first published in the mid of 1960s. The basic idea was to use parallel data and FDM with overlapping subchannel to avoid the use of high-speed equalization to combat impulsive noise and multipath distortion and fully utilize bandwidth.

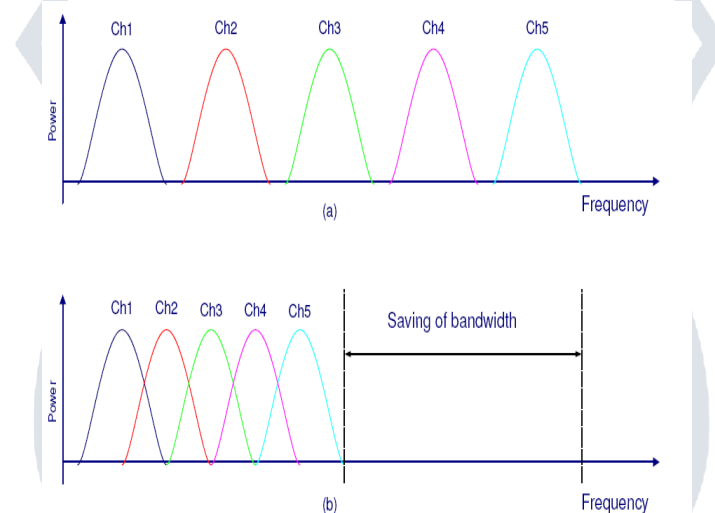

Figure 2 : Concept of OFDM Signal: (a) conventional multicarrier technique (FDM) , and (b) orthogonal frequency division multiplexing technique.

In Figure 2, we can observe the difference between non-overlapping multicarrier modulation technique and overlapping modulation technique. From figure 2(b) it is very clear that by using overlapping modulation technique we can save much more bandwidth than the non-overlapping one [9]. Weinstein and Ebert [10] applied the discrete Fourier transform (DFT) to parallel data transmission system as part of the modulation and demodulation process. In multicarrier transmission, bandwidth divided in many non-overlapping subcarriers but not essential that all subcarriers are orthogonal to each other as shown in figure 3 [9].

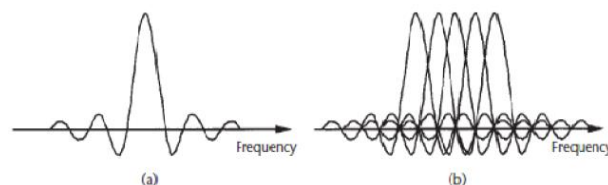

Figure 3: Spectra of (a) an OFDM subchannel, and (b) an OFDM signal

Orthogonal frequency-division multiplexing (OFDM) is a key technique in the mobile applications of 3G/4G system due to its capability of high rate transmission and robustness to inter-symbol-interference (ISI). It could combat the frequency selective fading effectively because of narrow bandwidth of each subcarrier. Furthermore, its implementation is low-complexity because the signal processing architectures need only IFFT, FFT and simple frequency-domain equalization. However, these advantages no longer exist when the channel response varies rapidly in time-domain because of the mobility of user equipment.

III. METHODOLOGY

In OFDM the concept of parallel data and FDM with overlapping sub channels to avoid the use of high-speed equalization to combat impulsive noise and multipath distortion and fully utilize bandwidth. The working of OFDM is shown in figure 4.

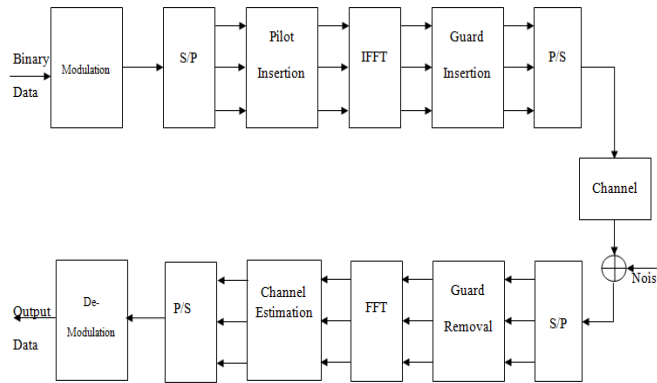

Figure 4: Block diagram of noise-corrupted LS Estimator

Least Square Channel Estimation

The Least Square (LS) estimation technique is preferred among many channel estimation technique. A modified and improved Least Square (LS) based channel estimation is designed on pilot sequence arrangement, shown in figure 5.

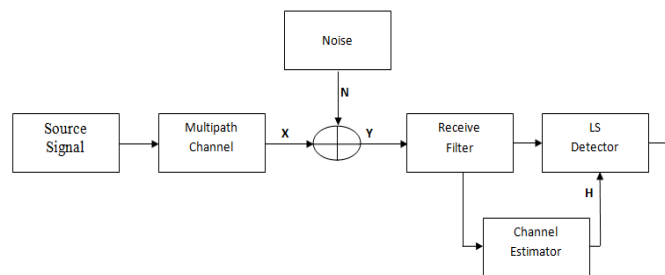

Figure 5: Block diagram of noise-corrupted LS Estimator

Channel and Signal Model

The method of channel estimation in which the Pilot Sequence are added after the signal is modulated and before the signal is transmitted. At the receiver pilot sequences are removed and the signal is extracted from the received signal.

The multipath time-varying channel model is considered in which the impulse response is expressed as:

$$H(n) = \frac{1}{\sqrt{N_p}} \sum_{p=0}^{N_p-1} \alpha_p e^{j \frac{2\pi}{N} f_{D_p} n} \delta(n-\tau_p)$$

Where, α_p , f_{D_p} and τ_p are the complex amplitude, normalized Doppler shift and time delay for the p th multipath arrival respectively.

For an OFDM signal the transmitted signal is expressed as:

$$X(n) = \frac{1}{N} \sum_{i=0}^{N-1} d_i e^{j \frac{2\pi}{N} i n}$$

Where, d_i is BPSK-modulated signal carried by the i th subcarrier, N is the number of subcarriers. After the modulation of OFDM, the pilot sequences are added to the signal and then transmitted.

The received signal can be expressed as:

$$Y(n) = H(n) X(n) + W(n)$$

Where, $Y(n)$ is the received signal, $X(n)$ is the transmitted signal, $H(n)$ is the impulse response and $W(n)$ is the additive white Gaussian noise (AWGN).

The received signal is derived from the convolution of the input signal and channel impulse response. After removing the pilot sequences, the received signal can be expressed as:

$$Y(n) = \frac{1}{N\sqrt{N_p}} \sum_{p=0}^{N_p-1} \alpha_p e^{j \frac{2\pi}{N} f_{D_p} n} \sum_{i=0}^{N-1} d_i e^{j \frac{2\pi}{N} i (n-\tau_p)} + W(n)$$

IV. EXPECTED RESULTS

The MATLAB/SIMULINK Communication tool box is used for implement the proposed model. In the channel estimation technique, the modified and improved Least Square (LS) method is designed on pilot sequence arrangement. The received signal which is receive at the receiver end which contain the pilot sequences, in which the number of bits are changed is estimated and detect the error in the signal. By which the Doppler diversity and the intersymbol interferences is reduced and the estimation could improve the BER performance.

V. CONCLUSION

The channel estimation method in which the OFDM transmission technique has emerged as a promising candidate for high data rate and reliable wireless communication systems. Due to channel interference, the accuracy of channel estimation is an essential factor for a good receiver design in order to exploit the full potential capacity of the OFDM systems. The modified and improved LS method has to be proposed for the better performance of the system.

REFERENCES

- [1] Jing Xue, Tao Luo, Dan Shan, and Weidong Xiang “Doppler Diversity Technique Based On Pilot-Aided Channel Estimation For OFDM Wireless Mobile Communication” IEEE Trans. Communication Technology and Application (ICCTA 2011), IET International Conference on 14-16 Oct. 2011.
- [2] C.Venkatesh and M.Madheswaran “A Novel Scheme for Least Square based Channel Estimation in OFDM Transmission System” IEEE Proceedings of International Conference 2008.
- [3] Markku Pukkila Channel estimation Modeling, Nokia research center HUT 19.12.2000.
- [4] Y. Li, N. Seshadri, and S. Ariyavisitak “Channel estimation for OFDM systems with transmitter diversity in mobile wireless channels,” IEEE J. Select. Areas Commun, vol. 17, pp. 461–470, Mar. 1999.
- [5] L. J. Cimini, Jr. B. Daneshrad, and N. R. Sollenberger, “Clustered OFDM with transmitter diversity and coding”, IEEE Global Telecommun. Conf., pp. 703–707, Nov. 1996.
- [6] L. J. Cimini and N. R. Sollenberger, “OFDM with diversity and coding for high-bit-rate mobile data applications,” in IEEE Global Telecommun. Conf., Phoenix, AZ, Nov. 1997, pp. 305–309.
- [7] Tao LUO, “Saturation throughput analysis of networks in Doppler spread scenarios”. IET Communications, vol 4, is s.7,p p.817-825,2010.
- [8] Israel Koffman and Vincentio Roman Broadband Wireless Access Solutions Based on OFDM Access in IEEE 802.16, IEEE Commun. Mag., vol. 40, no. 4, April 2002, pp. 96-103.
- [9] R. Prasad, “Introduction” in OFDM for Wireless Communications Systems, London, United Kingdom: Artech House, 2004, pp. 11-14.
- [10] S. B. Weinstein and P. M. Ebert, “Data Transmission by Frequency-Division Multiplexing Using the Discrete Fourier Transform,” in IEEE Trans. Commun. Technol., vol. COM-19, pp. 628-s634, Oct. 1971.