

A review on grid power quality improvement in wind energy system using STATCOM with BESS

¹Amitkumar Verma, ²Prof. P. L. Kamani, ³Prof.(Mrs.) R. R. Kapadia

¹P. G. Scholar, ²Associet Professor, ³Associet Professor(H.O.D.)

¹Masters in Electrical Engineering (Power System),

¹Government Engineering College, Bhuj, India

Abstract—The sources such as wind power and solar power are expected to be promising energy sources when it is connected to the power grid. The wind generators have a significant impact on the power quality, voltage profile and the power flow for customers and electricity suppliers. The power exhausted from above energy sources varies due to environmental conditions. Due to the fluctuation in nature of the wind, the wind power injection into an electric grid affects the power quality. The influence of the wind sources in the grid system concerns the power quality such as the reactive power, active power, voltage variation, harmonics and electrical behaviour in switching operation[1]. Demonstration of a grid side connected wind turbine is considered here with the problem arise due to the above system. At the point of common coupling a Static Synchronous Compensator with Battery Energy Storage System-STATCOM/BESS, can regulate four-quadrant active and reactive power, which is an ideal scheme to solve problems of wind power generation. As the power from wind generation varies with time so the battery energy storage used to maintain constant real power comprehensively from varying wind power. The power generated through wind generator can be stored in the batteries at low power demand hours[2-4]. The combination of battery storage with wind energy generation system will synthesize the output waveform by absorbing or injecting reactive power and enable the real power flow required by the load. The control strategy can coordinate charge or discharge of batteries with reactive power compensation of STATCOM, and balance the batteries capacity. If required, amount of energy consumed or given to the grid can be observed through an online smart meter connected in the circuit.

Index Terms—Power Quality, Statcom, Wind Energy, BESS

I. INTRODUCTION

Recently a rapid development of wind power generation has been experiencing in a global scale. As with increasing the size of wind turbines and wind farms, a large amount of wind power is injected into the power system. Due to random nature of wind energy a huge penetration of power may cause important problems and also affect the characteristics of the wind generators[1]. The integration of wind energy into existing power system presents a technical challenges and that requires consideration of voltage regulation, stability, power quality problems.

The power quality issues can be viewed with respect to the wind generation, transmission and distribution network, such as voltage sag, swells, flickers, harmonics etc. The voltage variation, flicker, harmonics causes the malfunction of equipments namely microprocessor based control system, programmable logic controller; adjustable speed drives, flickering of light and screen[2-4]. It may leads to tripping of contractors, tripping of protection devices, stoppage of sensitive equipments like personal computer, programmable logic control system and may stop the process and even can damage of sensitive equipments. The power quality is an essential measure and is greatly affected by the operation of a distribution and transmission network. So as the power quality problem is of great importance to the wind turbine generation.

To reduce the disturbances produced by variation in wind flow, we use the induction generator connected directly to the grid system. The induction generator is simple and robust having reactive power for excitation. However; induction generators require reactive power for magnetization. The active, reactive power and terminal voltage varies due to fluctuating wind[5-7]. A proper control scheme in wind energy generation system is required under normal operating condition to allow the proper control over the active power production. A STATCOM based control technology has been used for improving the power quality which can technically manages the power level associates with the commercial wind turbines. In the event of increasing grid disturbance, a battery energy storage system for wind energy generating system is generally required to compensate the fluctuation generated by wind turbine.

II. POWER QUALITY PROBLEMS

Perfect power quality means that the voltage is continuous and sinusoidal having a constant amplitude and frequency. Power quality can be expressed in terms of physical characteristics and properties of electricity. It is most often described in terms of voltage, frequency and interruptions. The quality of the voltage must fulfil requirements stipulated in national and international standards. In these standards, voltage disturbances are subdivided into voltage variations, flicker, transients and harmonic distortion.

A. Voltage Variation and Voltage Deep

The voltage variation can occur in specific situation, as a result of load changes, and power produce from turbine. These can expected in particular in the case of generator connected to the grid at fixed speed. The large turbine can achieve significantly better output smoothing using variable speed operation, particularly in the short time range[1]. The speed regulation range is also contributory factor to the degree of smoothing with the large speed variation capable of suppressing output variations. The start up of wind turbine causes a sudden reduction of voltage. Voltage sag is a phenomenon in which grid voltage amplitude goes below and then returns to the normal level after a very short time period. Generally, the characteristic quantity of voltage sag is described by the amplitude and the duration of the sags.

B. Switching Operation and Harmonics

Switching operations of wind turbine generating system can cause voltage fluctuations and thus voltage sag, voltage swell that may cause significant voltage variation. The acceptances of switching operation depend not only on grid voltage but also on how often this may occur. The harmonics distortion caused by non-linear load such as electric arc furnaces, variable speed drives, large concentrations of arc discharge lamps, saturation of magnetization of transformer and a distorted line current. The current generated by such load interact with power system impedance and gives rise to harmonics. The effect of harmonics in the power system can lead to degradation of power quality at the consumer's terminal, increase of power losses, and malfunction in communication system. The harmonics voltage and current should be limited to acceptable level at the point of wind turbine connection in the system.

C. Flickers and Reactive Power

Flicker is the one of the important power quality aspects in wind turbine generating system. Flicker has widely been considered as a serious drawback and may limit for the maximum amount of wind power generation that can be connected to the grid. Flicker is induced by voltage fluctuations, which are caused by load flow changes in the grid. The flicker emission produced by grid-connected variable-speed wind turbines with full-scale back-to-back converters during continuous operation and mainly caused by fluctuations in the output power due to wind speed variations, the wind shear, and the tower shadow effects. As a consequence, an output power drop will appear three times per revolution for a three bladed wind turbine. There are many factors that affect flicker emission of grid connected wind turbines during continuous operation, such as wind characteristics and grid conditions. Variable-speed wind turbines have shown better performance related to flicker emission in comparison with fixed-speed wind turbines.

Traditional wind turbines are equipped with induction generators. Induction generator is preferred because they are inexpensive, rugged and requires little maintenance. Unfortunately induction generators require reactive power from the grid to operate. The interactions between wind turbine and power system network are important aspect of wind generation system. When wind turbine is equipped with an induction generator and fixed capacitor are used for reactive compensation then the risk of self excitation may occur during off grid operation.

III. STATCOM AND BESS OVERVIEW

The principal benefit of the STATCOM for transient stability enhancement is direct through rapid bus voltage control. In particular, the STATCOM may be used to enhance power transfer during low-voltage conditions, which typically predominate during faults, decreasing the acceleration of local generators. An additional benefit is the reduction of the demagnetizing effects of faults on local generation. STATCOMs behave analogously to synchronous compensators, except that STATCOMs have no mechanical inertia and are therefore capable of responding much more rapidly to changing system conditions. When compared to synchronous machines, they do not contribute to short circuit currents and have no moving parts. However, the system has a symmetric lead-lag capability and can theoretically go from full lag to full lead in fraction of cycles.

A STATCOM, connected in shunt, with the system is capable of improving transient stability by compensating the reactive power at the point of common connection. The ultimate objective of applying reactive shunt compensation in a transmission system is to increase the transmittable power during transients. This is achieved by increasing (decreasing) the power transfer capability when the machine angle increases (decreases). In Figure 1, which shows the single line diagram of a STATCOM, if the DC capacitor voltage, V_{dc} , is increased from its nominal value, the STATCOM is "overexcited" (capacitive mode) and generates reactive power. If the voltage of the DC capacitor bank is decreased below the nominal value, the STATCOM is "under excited" (inductive mode) and absorbs reactive power from the system. This is completely analogous to increasing or decreasing the field voltage of a synchronous compensator.

The proposed STATCOM control scheme for grid connected wind energy generation for power quality improvement has current injection in such a way that it reduces the current harmonics as well as makes the source voltage at its desired value by adjusting the phase angle. The injected current will cancel out the reactive part and harmonic part of the load and induction generator current, thus it improves the power factor and the power quality. The grid connected system consists of wind energy generation system and battery energy storage system with STATCOM.

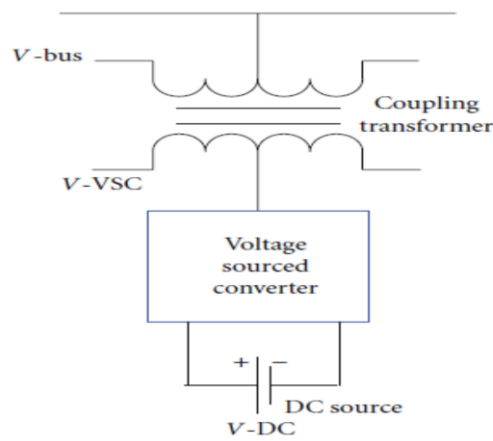

Figure – 1

Renewable energy sources often produce power and voltage varying with natural conditions (wind speed, sun light, etc). However, electric utility grid systems cannot readily accept connection of new generation plant without strict conditions placed on voltage regulation due to real power fluctuation and reactive power generation or absorption, and on voltage waveform distortion resulting from harmonic currents injected by nonlinear elements of the plant. Fluctuating wind speed also causes the system frequency to deviate from the 50 Hz standard, as many protection relays have the frequency margin of 1%, which causes the malfunction of the power system protection equipment.

As a result, it has become the major concern for the Transmission System Operators (TSO) or the utility companies to resolve the wind power smoothing issue. Energy Storage System (ESS) is needed to smooth the intermittent output power fluctuations of the wind farm. A lot of choices for the ESS are present nowadays in the market e.g. Pumped Hydro Energy Storage (PHES), Compressed Air Energy Storage (CAES), Flywheel, Super capacitors Energy Storage (SES), Superconducting Magnetic Energy Storage (SMES), Hydrogen Energy Storage System (HESS), Batteries Energy Storage System (BESS), etc, which are used to overcome the fluctuated wind farm output power.

The choice of the ESS in the electric system network depends upon the desired application. To meet the electric power quality problems, energy storage with fast response rate and ability to charged/discharged many times is needed. For the time scale of seconds-to minutes, a suitable energy storage system is needed to have a good ramp rates, as discussed earlier, flywheel, super capacitors, batteries might be a good option. Besides that, the chosen energy storage system should be able to provide rated power for longer periods.

However, for the longer time scales, the charging/discharging rate becomes less important and the choice of the ESS depends upon the amount of stored energy and the power capacity. Currently, the Pumped Hydro Storage System (PHSS) is the most common storage technology for longer time scales applications. Different types of batteries are presented as the substantial choice for the ESSs which are Sodium Sulfur (NaS), Lithium-Ion (Li-ion), Nickel Metal, Nickel Cadmium and Lead Acid type's batteries. Among different types of batteries, Lead Acid is the most popular and oldest technology. It has low capital investment and has the vast experience of usage. Lead-acid batteries requires frequent maintenance, they have short life (often 3-5 years), risk of explosions, acid leaking and are not environment friendly. They are majorly used as backup sources nowadays. Nickel Cadmium type battery appears as an alternative for the lead-acid battery. They have longer life time, less temperature dependent and high charge rates. They have a disadvantage of crystallization; it decreases the capacity of the battery when the battery is idled. Nickel metal type hybrid battery has higher energy density as compared to the lead acid and nickel cadmium, but they need a special charging control.

Sodium-Sulfur (NaS) type battery system has a modular structure. It is the most recent technology among other technologies of the batteries. NaS uses the molten metal and operates at temperature above 250° C. They have very high power densities and works good for storing bulk amount of power. They have longer life time i.e. 15 years and they are relatively inexpensive.

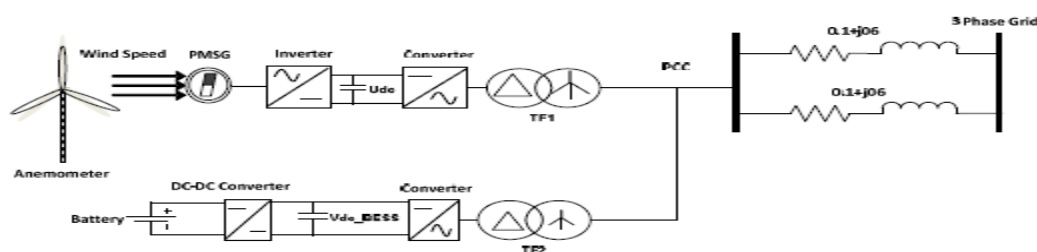

Figure – 2

The BESS has non-linear characteristics therefore the proper representation of BESS and its controllers is challenge. The simplest and most commonly used model of a battery consists of the constant internal resistance in series with the variable DC voltage source. Previous studies of the STATCOM are limited only up to the reactive power compensation, but with the recent advancement of the BESS, it is possible to control the real power as well using BESS integrated with STATCOM system on the DC side. Thus allows us the controlling of the real and reactive power independently. Studies shows that the BESS integrated with STATCOM could solve the power fluctuation problems besides that it also improves the stability of the wind farms during the short circuit disturbances by supplying the adequate reactive power support to the system. Besides that, it also has other possible applications, e.g. voltage control, frequency regulation, and power oscillation damping.

IV. STATCOM WITH BESS CONFIGURATION

Voltage or current source inverter based flexible AC transmission systems (FACTS) devices such as static var compensator (SVC), static synchronous compensator (STATCOM), dynamic voltage restorer (DVR), solid state transfer switch (SSTS) and unified power flow controller (UPFC) have been used for flexible power flow control, secure loading and damping of power system oscillation. But FACTS/ESS, i.e., FACTS with energy storage system (ESS) have recently emerged as more promising devices for power system applications. This work focuses on STATCOM incorporated with battery energy storage system (BESS), i.e., STATCOM/BESS topology for wind power application.

Figure-3 presents typical architecture of connected STATCOM with BESS to electric utility system. The static synchronous compensator, or STATCOM, is a shunt-connected power electronic converter-based FACTS device. Unlike static var compensator (SVC), the STATCOM does not employ capacitor or reactor banks to produce reactive power. The major disadvantage of a traditional STATCOM (with no energy storage) is that it has only two possible steady-state operating modes, namely, inductive (lagging) and capacitive (leading).

Even though both the traditional STATCOM output voltage magnitude and phase angle can be controlled, they cannot be independently adjusted in steady state due to the lack of significant active power capability of STATCOM. Typically, the STATCOM converter voltage is maintained in phase with the PCC voltage, thus ensuring that only reactive power flows from the STATCOM to the system.

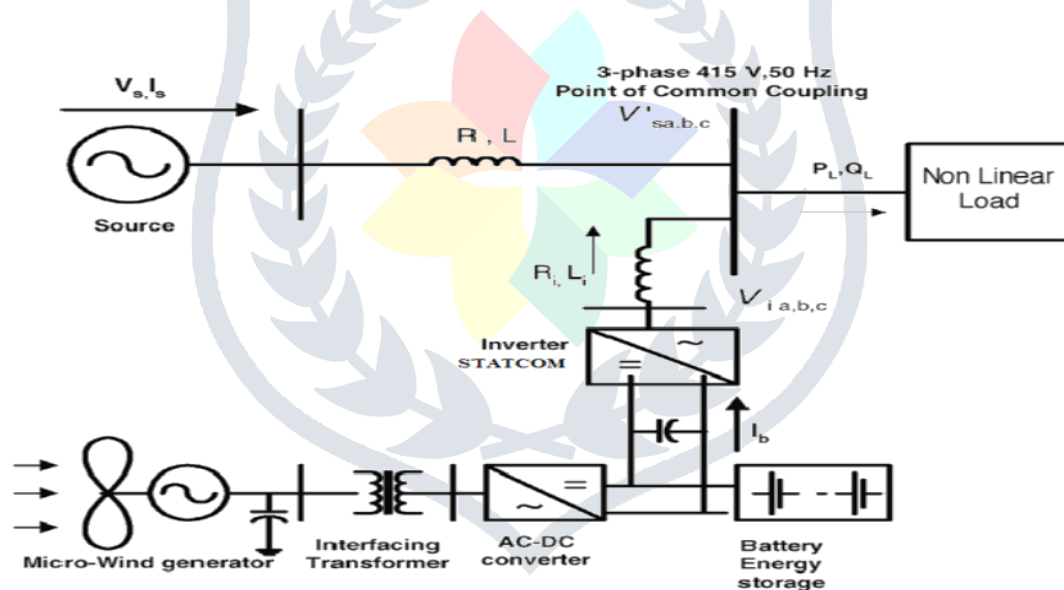

Figure – 3

However, the real power capability of the STATCOM is very limited due to the absence of any energy storage at DC bus. Compared with the traditional STATCOM, the STATCOM + BESS offer more flexibility. In case of STATCOM + BESS, the number of steady-state operating modes is extended to various situations such as inductive mode with DC charge and DC discharge, capacitive mode with DC charge and discharge. Thus, in steady state, the STATCOM + BESS has four operating modes and can operate at every point in the steady-state characteristic circle. In addition, depending on the energy output of the battery or other ESS, the discharge/charge profile is generally sufficient to provide enough energy to stabilize the power regulation in the system and maintain operation until other long-term energy sources are brought into operation. One of the drawbacks of FACTS + ESS is that for FACTS integration, the size of the storage systems, particularly battery energy storage (BESS), may be too large for practical use in large-scale transmission-level applications.

On certain occasions, large battery systems tend to exhibit voltage instability when numerous cells are placed in series. However, typically it is seen that even large oscillations can be mitigated with modest power injection from a storage system. The ability to independently control both active and reactive powers in STATCOM + BESS makes them ideal controllers for various types of power regulation system applications, including voltage fluctuation mitigation and oscillation damping. Among them, the most important use of the STATCOM + BESS is to stabilize any disturbances occurring in the power system.

V. CONTROL STRATEGY

The control scheme with battery storage and micro wind generation system utilizes the dc link to extract the energy from the wind. The wind generator is connected through a step up interfacing transformer and to the rectifier bridge so as to obtain the dc voltage. Also a lead acid cell battery is used for maintaining the dc bus voltage constant. Thus the inverter is implemented successfully in the distributed system. The control scheme approach is based on injecting the current into the grid using hysteresis band current controller. Using such techniques controller keeps the control system variables between the boundaries of hysteresis area and thus gives correct switching signals for the inverter operation. Fig. 4 shows the control scheme for generating the switching signals to the inverter.

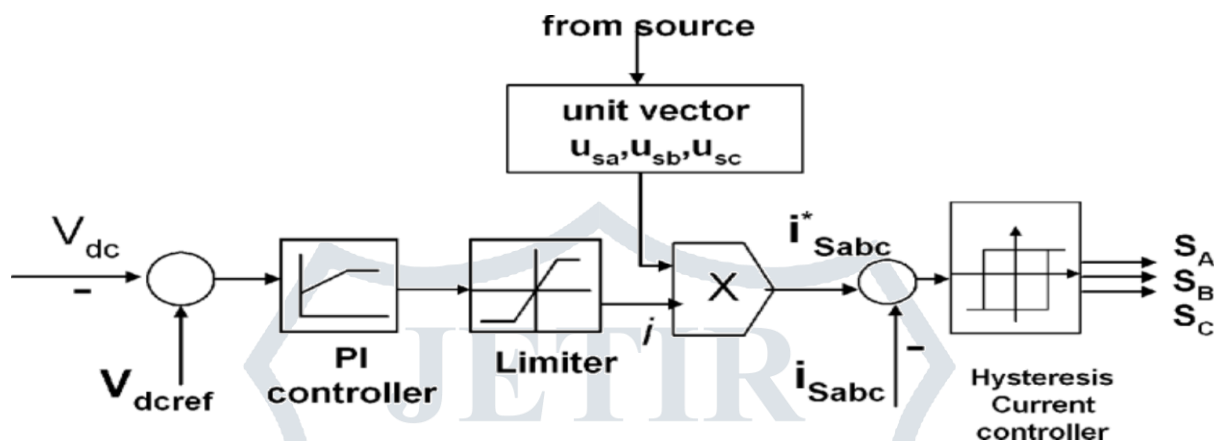

Figure – 4

The control algorithm needs the measurement of several variables such as three-phase source current i_{Sabc} for each phases, dc bus voltage V_{dc} , and inverter current i_{iabc} with the help of measurement sensors. The current control unit receives an input of reference current i^*_{Sabc} and actual current i_{Sabc} is measured from each phases respectively, which are subtracted so as to activate the operation of the inverter in current control mode.

VI. ACKNOWLEDGMENT

The completion of any project brings with it a sense of satisfaction, but it is never complete without thanking those people who made it possible and whose constant support has crowned our efforts with success. One cannot even imagine the power of the force that guides us all and neither can I succeed without acknowledging it. My deepest gratitude to Almighty God for holding my hands and guiding me throughout our lives.

I wish to express my deep sense of gratitude to my Guide, **Prof. Piyush Kamani**, Associate Professor in Electrical Engineering Department of Government Engineering College, Bhuj for his able guidance and useful suggestions, which helped me in completing the seminar work, in time. I would also like to extend my gratitude to **Prof. (Mrs.) R. R. Kapadia**, Head of Electrical Department in Government Engineering College, Bhuj and all the faculty members of Electrical Department for their invaluable and precious guidance and continuous encouragement and motivation. I would also like to thank my family and my friends at Government Engineering College, Bhuj for their support and help during the course of seminar work.

REFERENCES

- [1] Mundackal, J.; Varghese, A.C.; Sreekala, P.; Reshmi, V., "Grid power quality improvement and battery energy storage in wind energy systems," *Emerging Research Areas and 2013 International Conference on Microelectronics, Communications and Renewable Energy (AICERA/ICMiCR)*, 2013 Annual International Conference on , vol., no., pp.1,6, 4-6 June 2013
- [2] Nirmala, N.; Kumar, V.S., "A STATCOM-control scheme for wind energy system to improve power quality," *Information Communication and Embedded Systems (ICICES)*, 2013 International Conference on , vol., no., pp.1108,1113, 21-22 Feb. 2013
- [3] Shanthini, K.; Verappan, N., "Power quality enhancement of wind generators connected to grid," *Emerging Trends in Electrical Engineering and Energy management (ICETEEEM)*, 2012 International Conference on , vol., no., pp.398,403, 13-15 Dec. 2012
- [4] Sattar, A.; Al Durra, A.; Caruana, C.; Muyeen, S.M.; Tamura, J., "Real time implementation of the BESS to smoothen the output power fluctuation of the variable speed wind turbine generator," *Electrical Machines and Systems (ICEMS)*, 2012 15th International Conference on , vol., no., pp.1,6, 21-24 Oct. 2012
- [5] Mohod, S.W.; Aware, M.V., "A STATCOM-Control Scheme for Grid Connected Wind Energy System for Power Quality Improvement," *Systems Journal, IEEE* , vol.4, no.3, pp.346,352, Sept. 2010

- [6] Muyeen, S.M.; Takahashi, R.; Murata, T.; Tamura, J.; Ali, M.H., "Stabilization of wind farms connected with multi-machine power system by using STATCOM/BESS," *Electrical Machines and Systems, 2007. ICEMS. International Conference on*, vol., no., pp.232,237, 8-11 Oct. 2007
- [7] Francisco Diaz Gonzalez¹, Marcela Martinez-Rojas (2011) "Strategies for Reactive Power Control in Wind Farms with STATCOM" IREC Catalonia Institute for Energy Research.
- [8] Yuvaraj,Dr.S.N.Deepa N.D. (2011) "Improving grid power quality with FACTS device on integration of wind energy system" student pulse | april 2011 | vol.3, issue 4 ,www.studentpulse.com
- [9] Ganesh.Harimanikyam,S.V.R.Lakshmi Kumari (2012) _Power quality improvement of grid connected wind energy system by STATCOM for balanced and unbalanced linear and nonlinear loads| International Journal of Engineering Research and Development e- ISSN: 2278-067X, ISSN: 2278- 800X,www.ijerd.com Volume 3, Issue 1 (August 2012)
- [10] A. Arulampalam, M. Barnes, N. Jenkins and J.B. Ekanayake, "Power quality and stability improvement of a wind farm using STATCOM supported with hybrid battery energy storage" IEE Proc.-Gener. Transm. Distrib., Vol. 153, No. 6, November 2006.
- [11] A. Chakraborty, S. K.Musunuri, A. Srivastava, A. Kondabathini, "Integrating STATCOM and Battery Energy Storage System for Power System Transient Stability: A Review and Application," Hindawi Publishing Corporation, Advances in Power Electronics, Volume 2012, Article ID 676010
- [12] V.Suresh Kumar,Ahmed F.Zobaa, R.Dinesh Kannan and K.Kalaiselvi (2010) "Power quality and stability improvement in wind park system using STATCOM" JJMIE Volume 4, Number 1, Jan. 2010 ,ISSN 1995-6665 Jordan Journal of Mechanical and Industrial Engineering
- [13] M.Chiranjeevi, O.Venkatanatha Reddy (2012) "A Bess-STATCOM based control scheme for grid connected wind Energy system for power quality improvement" International Journal of Engineering Research and Applications (IJERA) ISSN: 2248-9622 www.ijera.com Vol. 2, Issue 2,Mar-Apr 2012
- [14] Meera Shareef Shaik,Ratna Raju (2012) "Effective integration of wind generating station to power grid with STATCOM" issn: 2250-3676 [ijesat] international journal of engineering science & advanced technology volume-2, issue-3.
- [15] Y. Chauhan, S. Jain, and B. Sing (2008)—Static volt-ampere reactive compensator for self-excited induction generator feeding dynamic load,| Electric Power Compon. Syst. J., vol. 36, no. 10, pp. 1080–1101.p

