

An Adaptive Hand-free Design Technique for Mobile Communication in Vehicle

Ms.Surya T,Mr.Ramesh K
M.tech-Embedded System SRM university , Asst.Professor SRM University
Department of Electronics and Communication,
SRM University ,Chennai, India

Abstract— Nowadays Using mobile phone has increased worldwide at the same time we have to consider the risk associated with it. Using a mobile phone while driving can affect the cognitive functions of persons, distract his or her visual concentration and also the speed of processing information. The theme of the project is to make the driver to attend only the emergency calls. Initially when a call is made to driver then he will receive a message intimating that he is in driving. If once again the person makes a calls to the driver then the driver will understood that it is emergency. So the driver will get an intimation regarding the emergency call in voice and automatically the car speed need to be reduced using PWM in order to prevent accidents due to mobile phone

Keywords — Mobile Phone, GSM Modem, Ultrasonic, Heart Beat Sensor, PWM Technique.

I. INTRODUCTION

Using a mobile phone while driving can affect the cognitive functions of persons, distract his or her visual concentration and also the speed of processing information Though many hand free device like Bluetooth, ear phones are there but still no improvements for avoiding accidents. If we are using these hand free devices we will lose our concentration these may leads to accidents . Some of the figures which will show the procedures to avoid accidents by using an hand free device.

The predicament is there are so many diversions when we drive already that are identical to talking over the phone, and not automatically from within the car. In the end, safety is our target. The predicament is there are so many diversions when we drive already that are identical to talking over the phone, and not automatically from within the car. Hands free phone kits are considered to increase safety due to the fact operators no longer have to hold the mobile phone to have a conversation. The driver's hands stay put on the wheel and eyes on the road. Actually the process is the same as talking to someone next to you.

II. TRANSMITTER SECTION

Here we will be using an GSM Modem through this GSM Modem the driver will get a call then in UART using max 232 ic will receive the digital information and transmit it to the microcontroller through a single wire. If the driver didn't get any call these 4 bit digital information will be transmitted to the receiver,. for the first time if he gets call then the dialer will receive a message that he is in driving, then the transmitting 4 bit data will be encoded and given to the RF transmitter. It is more difficult to drive safely and have a complex conversation in light traffic .Complex conversation needs more attention and takes your mind off the road. When your mind is not on the road, someone could die.

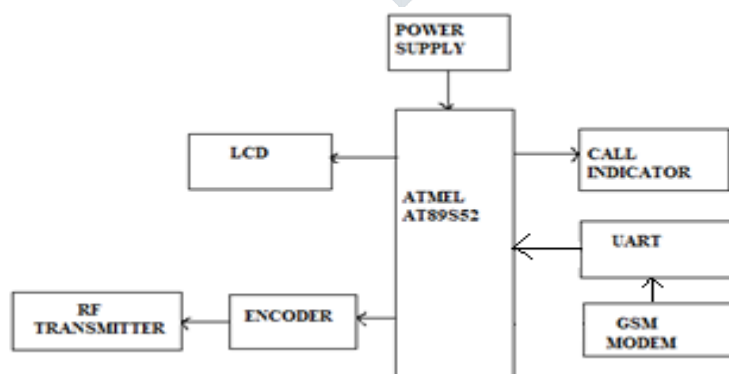

Figure1: Transmitter section

III RECEIVER SECTION

In this receiver section the 4 bit digital data will be decoded and it will be given to the microcontroller this will check with the data that are encoded . if once again the driver will gets a call from the same number, then the driver will get an intimation in voice that it's an emergency call then that message will be displayed in LCD at the same time the call indicator will also blink. Ultrasonic sensor is used to measure the distance between an moving object or stationary object. Heart beat sensor which is used to measure the heart beat rate of the driver.

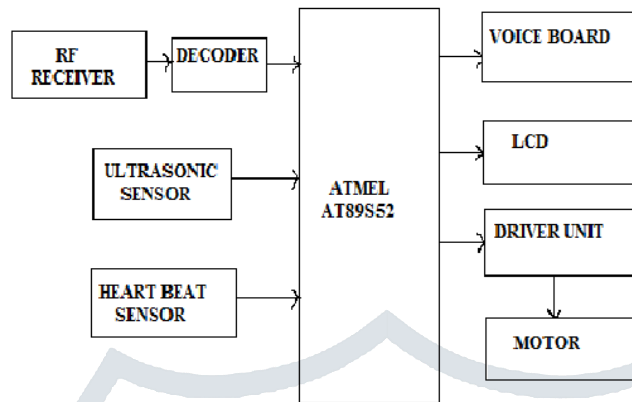

Figure2: Receiver section

There are some few steps to follow after entering into the vehicle



Figure3: Setting Profile,Time

(1) we have to set the profile as driving then set the time taken to reach the destination .(2) If we get an emergency call means we will get a call from the same number for 2 or more times continuously then automatically a message will be send to the dialer that the user is in driving .The user cannot be able to make an outgoing call.

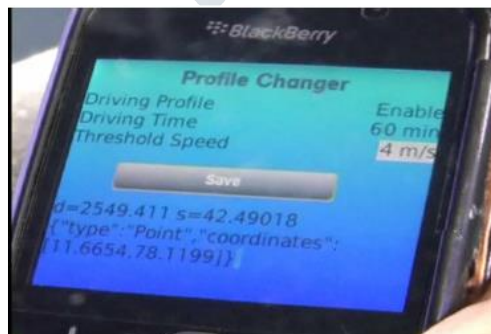

Figure4: Profile changer

If the dialer makes an call to the user who is in driving will receive an message that the “User is in driving” so please call back after some XX minutes if it is an emergency call make call 2 or more times continuously,here XX is the time interval between the total journey.



Figure5: Message received

The RF module is always used along with an encoder in transmitter and a decoder in the receiver section. The encoder is used for encoding the parallel data for transmission and in receiver it is decoded by a decoder.

UART is used to convert the transmitted information from serial or sequential to parallel form at each end of the link. These messages will be displayed in the LCD display.

“Ultrasonic sensor” which will detect if any vehicle is going to hit or not this will measure the distance between our front and rear side vehicle. Ultrasonic sensors will generate a high frequency sound waves Sensors will calculate the time interval between sending the signal and the echo which is coming back from the sensor from that it will determine the distance to an object.

Heart beat sensor which will measures the person’s BPM(Beat per minute). Heart beat sensor is designed to give digital output of heart beat when a finger is placed on it. When the heart beat detector is working, the beat LED flashes in union with each heart beat this digital output can be connected to microcontroller directly to measure the beat pre minute(BPM)rate.

These are all will be displayed in the LCD display.

LCD doesn’t know about the content that are transmitted into the data bus,so we have to specify whether it’s a data or command .

If it’s command then, RS=0, R\W=0, E=1\0

Then for Data :RS=1, R\W=0, E=1\0

These emergency call can be displayed in LCD as well as in an call indicator and in Voice board these message will be indicated and ultrasonic sensor which will measure the distance between the vehicle and if any vehicle is going to hit means then in voice board it will be indicated that the vehicle is going to hit . This voice board consists of an Auto rewind mode which has an application that it configures the device to automatically rewind the message .Using this voice board we can store upto 8 messages.

Mainly accidents are happening due to usage of mobile phone or consumption of alcohol while driving which will cause road accidents. Though many hand free devices are introduced but still these devices does not give any improvements to avoid road accidents.

IV GSM MODULE

The GSM Modem supports popular "AT" command set so that users can develop applications quickly. This GSM Modem consists of an SIM Card holder in which we have to insert an activated SIM card for normal use. The power to this unit can be given from UPS to provide uninterrupted operation. Through this AT command we can control the GSM Modem then the sample codings are below

To invoke the C51 or CX51 compiler, enter **C51** or **CX51** at the command prompt. On this command line, you must include the name of the C source file to be compiled,

These are some format for the **Cx51** command line :

C51 source file_directives..._

CX51 source file _directives..._

or:

C51 @command file

CX51 @command file

where:

source file is the name of the source program you want to compile.

directives are used to control the function of the compiler.

V SAMPLE CODING

Initially if we want send a character then we have to store that character in SBUF until if the transmitter is transmitting that character to the receiver this TI will be 0 after transmitting this will become 1, similarly for receiver also until the character is received from the transmitter this RI will be 0 after receiving this will become 1. If we want to send a string then the str(string value) will be incremented after that we have to give some delay then here AT commands are used to control the modem it uses an separate command for each operation.

```
serialtxstr("VEHICLE SECTION\n");
while(1)
{
while(RI==1)
{
RI=0;
serialtxstr("AT\n");seriatTx(0x0d);
delay(65000);

serialtxstr("AT+CMGF=1\n");seriatTx(0x0d);
delay(65000);

serialtxstr("AT+CMGS=\n");seriatTx("");serialtxstr("9459646496\n");seriatTx("");seriatTx(0x0d);
delay(65000);

serialtxstr("USER IS IN DRIVING...\n");seriatTx(0x1a);
delay(65000);
}
}
```

The output for the coding done for GSM-UART in Embedded C programming language and using KEIL C compiler for simulating the program. In this above program GSM is interfaced with AT89S51 microcontroller and the output will be like sending message to the dialer stating that the user is in driving, stating that the user is in driving.

The programs of the microcontroller have been written in Embedded C language and were compiled using KEIL, a compiler used for microcontroller programming. The communication between PC and the microcontroller was established using an MAX 232 standard and those programs were also done in C language.

Some of the applications we have included to enhance our safety such as ,Ultrasonic sensor which is used to measure the distance of the object which is coming from front and rear sides on the road[8]. This sensor will measure the distance of an object upto 8 meters[9].

$$\text{Distance in cm} = (\text{Echo pulse width high time} * \text{Sound Velocity}(340\text{M/S})/2)$$

or

$$\text{Distance in cm} = (\text{Echo pulse width high time (in uS)}*0.017)$$

Heart beat sensor which will measures the person's BPM (Beat per minute)[10]. The normal heart beat rate for a person when he is in rest is 60-100 BPM. However, the rate will be increased when there is a change in their physical activity.

The maximum heart rate depends on the person's age and this HBR decreases when the age of the person increases. The contraction and relaxation will causes blood to flow in and out of the heart[10]. During each cardiac cycle, a certain group of tissues in the heart which will generate pulse to spread to the heart for contraction and relaxation of the heart muscles[10]. During each cardiac cycle, the blood vessels will generate a pulse in order to carry blood to different parts of the human body[11]. The beat per minute can be calculated by using this formula,

$$\text{BPM}=60*f$$

Heart beat sensor is designed to produce output in digital when a finger is placed on the LED. When the heart beat detector is working ,then the beat LED will be blinking for each heart beat[10]. This digital output can be connected to microcontroller directly to measure the beat per minute(BPM)rate[11].

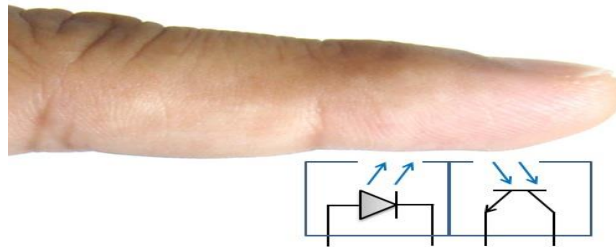

Figure6: Heart Beat sensor

We can use any of the photo diode or LED which will emit light to the tissue of our finger and the received light will be transmitted to the photo transistor then[11], the pulse will be like this as below when our BPM is normal if it is abnormal the pulse width will be varied.

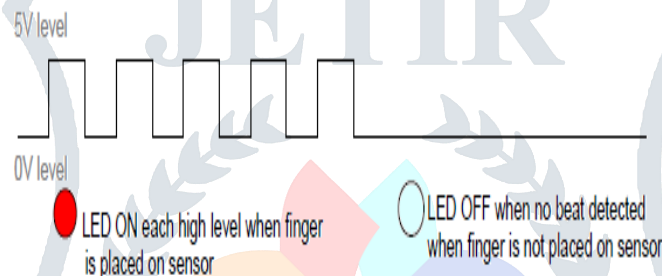

Figure7: Output pulse generated by heart beat sensor

VI PWM TECHNIQUE

If we get an emergency call means we will get a call from the same number for 2 or more times continuously. Using this PWM technique[12]. we can reduce the speed of the vehicle after receiving an emergency call. These are some sample code to reduce the speed of the motor.

```

sbit rf=P1^0;
sbit motor=P1^1;
sbit call=P1^2;

void delay(unsigned int t)
{ while(t--);}

void main()
{
rf=0;motor=1;call=0;
while(1)
{
if(rf==1)
{
call=1;
motor=1;
delay(10000);
motor=0;
delay(5000);
}
else

```



```
{  
call=0;motor=1;  
}  
}  
}
```

We have to initialize port 1 for rf, call, motor and after some delay we have to check if emergency call occur then call indicator, motor, rf will be 1.

VII RESULTS

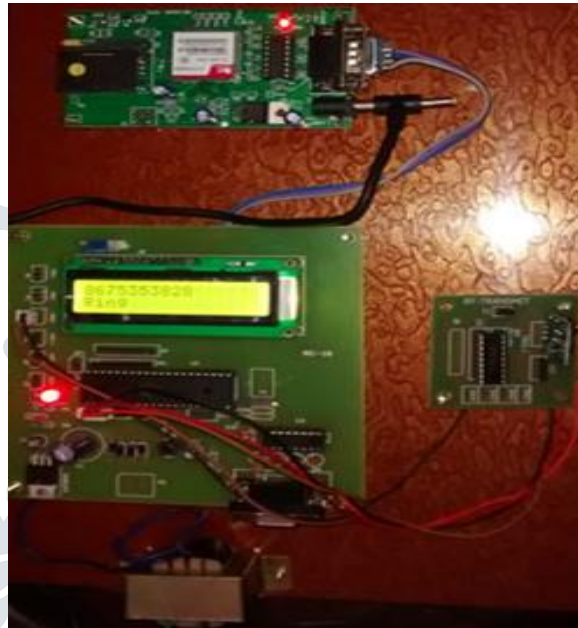

Figure8: Transmitter section

Through this GSM Modem we are going to send message to the dialer stating that the person is driving[1].Using AT Commands we can control the GSM modem and as well as this will check whether microcontroller and GSM modem are communicating.If it not communicating properly an error message will be shown in LCD.

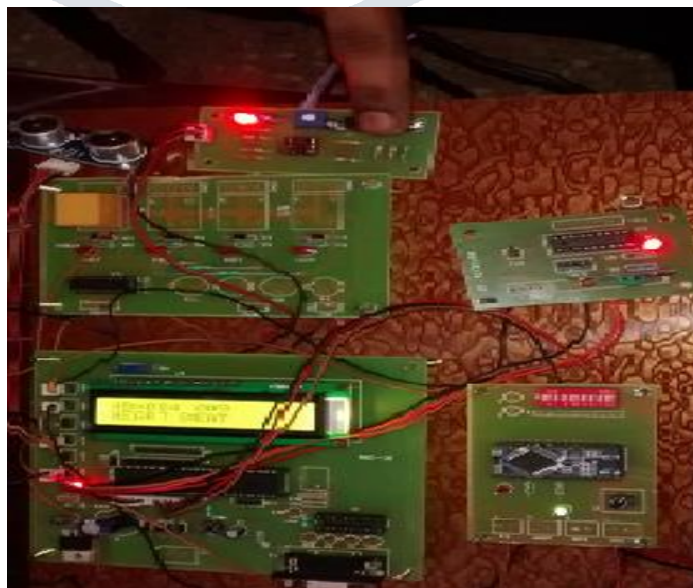

Figure9: Receiver section

In the receiver section an Ultrasonic sensor is connected to determine the distance of the vehicle which is coming beside of our vehicle[7].If any vehicle is going to hit then we will get a message in voice that an obstacle detected using voice board[6]. Heartbeat sensor is used to measure the driving person heart beat per minute that will displayed in LCD.

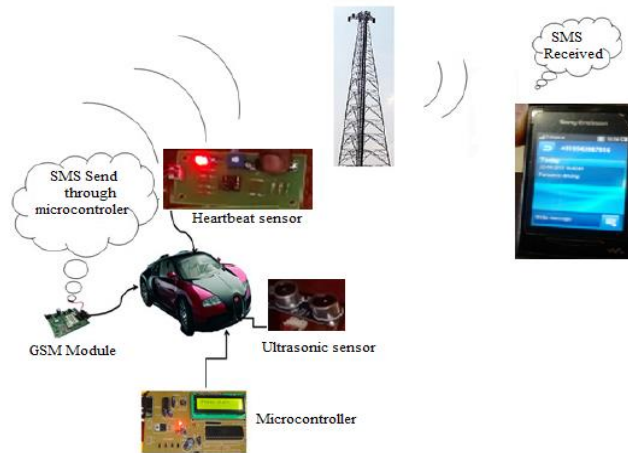

Figure10: System Architecture for Accident free driving

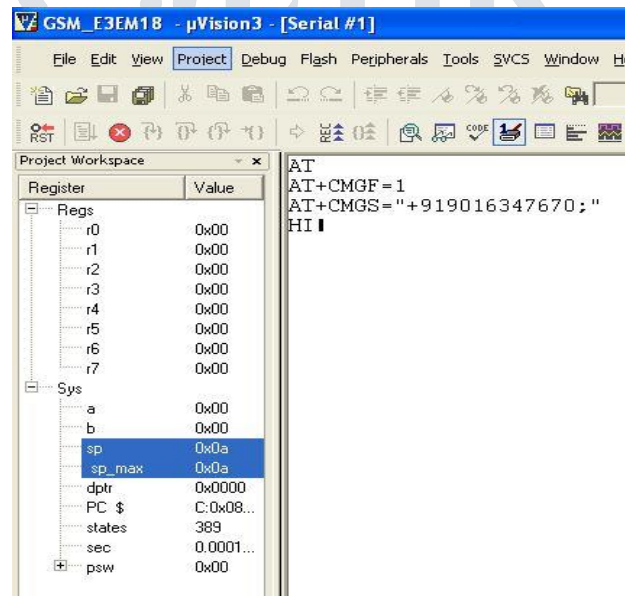

Figure11: Output for sending message using GSM Modem

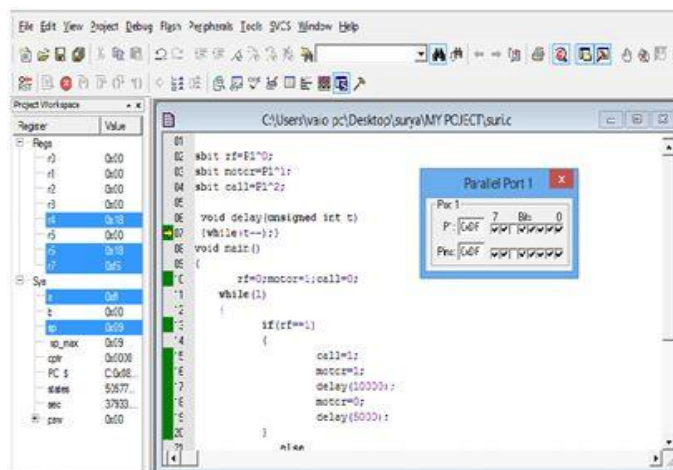

Figure12:Output for motor speed control using PWM technique**VIII CONCLUSION**

We concluded that the implementation of the above invention helps in reducing the risk of using mobile phone while driving. First of all we have to negligible almost all calls and messages our government have enacted many laws but still this road accidents are happening for that they have taken many precautionary measures for avoiding road accidents because of using mobile phone. By using this method we can reduce the road accidents.

IX ACKNOWLEDGEMENT

I submit my gratitude and sincere thanks to my guide Mr.K.Ramesh, Department of electronics and communication For his motivation and support during the course of my work.I truly appreciate and value his esteemed guidance and encouragement from the beginning to the end of this thesis.I would not able to do justice to this paper of mine, if I do not express my heartiest thanks to our coordinator Prof.V.Natarajan providing a solid background for my studies and research thereafter .They have been great source of inspiration and I thank them from the bottom of my heart.

REFERENCES

- [1] An analysis ,design and precautionary measure for mobile phone accidents while driving and cost effective fatalities. H .abdul shabeer/Ph.d Research scholar, Department of Electronics and Communication,Anna university,IEEE 2011.
- [2] J. Jansson and F. Gustafsson, "A framework and automotive application of collision avoidance decision making," *Automatica*, vol. 44, no. 9, pp. 2347–2351, Sep. 2008
- [3] J. Hillenbrand, A. Spieker, and K. Kroschel, "A multilevel collision mitigation approach—Its situation assessment, decision making, and performance tradeoffs," *IEEE Trans. Intell. Transp. Syst.*, vol. 7, no.4, pp. 528–540, Dec. 2006
- [4] A.Broadhurst, S. Baker, and T. Kanade, "A prediction and planning framework for road safety analysis, obstacle avoidance and driver information," in *Proc.11th World Congr. Intell. Transp. Syst.*, Oct 2004.
- [5] Kai-Tai song ,"Design and experimental study of an ultrasonic sensor system for lateral collision avoidance at low speeds"IEEE jun 2004.
- [6] Muhaiyiddin.F,"Development of digital vehicle Distance monitoring system"IEEE Apr 2009.
- [7] R.G.Landaeta,O.Class,and R.P.Areny,"heart rate Detection from plantar bioimpedance measurements",28th IEEE EMBS. Annual International Conference,USA,2006,pp5113-5116.
- [8] Y.Chen."Wireless heart beat rate monitor with infrared detection module,"US2005075577-A1,2005.
- [9] K. K. Wong and T. K. Ho, "Dwell-time and run-time control for DC mass rapid transit railways," *IET Electr. Power Appl.*, vol. 1, pp. 956–966, Nov 2007.
- [10] N. Kaempchen, B. Schiele, and K. Dietmayer, "Situation assessment of an autonomous emergency brake for arbitrary vehicle-to-vehicle collision scenarios," *IEEE Trans. Intell. Transp. Syst.*, vol. 10, no. 4,Dec. 2009.