

Design and Implementation of Automatic Fire Alarm System based on Wireless Sensor Networks

Mr. Santosh P. Patange

M.E. Student, Aditya College of Engineering, Beed

Mr. Sagar V. Yadav

M.E. Student, Aditya College of Engineering, Beed

Abstract –Fire disaster is a great threat to lives and property. Automatic fire alarm system provides real-time surveillance, monitoring and automatic alarm. It sends early alarm when the fire occurs and helps to reduce the fire damage. Wireless sensor network has become the most important technology in environmental monitoring and home or factory automation in recent years. In this paper, an automatic fire alarm system based on wireless sensor networks is developed, which is designed for high-rise buildings. In order to provide early extinguishing of a fire disaster, large numbers of detectors which periodically measure smoke concentration or temperature are deployed in buildings. Those scattered detectors report their monitoring information to the surveillance center via the self-organizing hierarchical wireless sensor networks. Test results from the prototype system show that the automatic fire alarm system achieves the design requirements.

I. INTRODUCTION

Fire disaster is a great threat to lives and property. Automatic fire alarm system provides real-time surveillance, monitoring and automatic alarm. It sends early alarm when the fire occurs and helps to reduce the fire damage. Wireless sensor network has become the most important technology in environmental monitoring and home or factory automation in recent years. In this paper, an automatic fire alarm system based on wireless sensor networks is developed, which is designed for high-rise buildings. In order to provide early extinguishing of a fire disaster, large numbers of detectors which periodically measure smoke concentration or temperature are deployed in buildings. Those scattered detectors report their monitoring information to the surveillance center via the self-organizing hierarchical wireless sensor networks. Test results from the prototype system show that the automatic fire alarm system achieves the design requirements.

Nowadays, securing one's property and business against fire is becoming more and more important. Monitoring commercial

and residential areas all-round is an effective method to reduce personal and property losses due to fire disasters. Automatic fire alarm system is widely deployed in those sites recent years. Large numbers of small fire detectors should report their information to the control center of a building or a block. But the cost of wiring is very high in traditional wired fire alarm systems.

Networking without pre-exist infrastructure reduces the wiring cost greatly. In recent years, wireless sensor networks (WSNs) are widely deployed in environmental monitoring, structural health monitoring and industrial monitoring. It provides low cost solutions for such applications. It consists of small size, low-power, and low-cost devices that integrated with limited computation, sensing, and radio communication capabilities. So WSN is very suitable for communication between detectors in fire alarm system.

II. LITERATURE REVIEW

[1] Building Fire Emergency Detection and Response Using Wireless Sensor Networks Yuanyuan Zeng, Seán Óg Murphy, Lanny Sitanayah, Tatiana Maria Tabirca, Thuy Truong, Ken Brown, Cormac J. Sreenan Department of Computer Science, University College Cork :

Wireless sensor networks (WSNs) provide a low cost solution with respect maintenance and installation and in particular, building refurbishment and retrofitting are easily accomplished via wireless technologies. Fire emergency detection and response for building environments is a novel application area for the deployment of wireless sensor networks. In such a critical environment, timely data acquisition, detection and response are needed for successful building automation. This paper presents an overview of our recent research activity in this area. Firstly we explain research on communication protocols that are suitable for this problem. Then we describe work on the use of WSNs to improve fire evacuation and navigation

[2]Avoidance of Fire Accident on Running Train Using ZigBee Wireless Sensor Network R. Pitchai Ramasamy¹ , M. Praveen Kumar¹ , S. Sarath Kumar² and R. Raghu Raman³:-

The main objective of our proposed system is to safeguard people's life and government property. This paper will focus on the system that will detect and control the fire accidents on running train. In-house parameters such as temperature and humidity in the each coach can be monitored in real time. From the information collected by the sensor system, decisions for firefighting, alarming, and automatic water sprinkler system can be made more quickly by the relevant system or engine driver. After receiving the signal, the engine driver will stop the train and take necessary action. Key Terms: Fire alarm system, Fire protection systems, Wireless sensor network, Automatic sprinklers, Signal transmission.

The trains are moderate vehicles used for transporting people and goods. Mostly, the people prefer the train journey for longer distance as it is cheaper. Since induction of train for public transportation, the fire accidents are not catered seriously by the Indian Railways. The notices showing "Do not smoke", "Do not carry inflammable material" are the only precautionary warnings about the fire in each compartment. However, because of failure in routine maintenance system or by the activities of illegal social elements, the fire accidents in train occur frequently

[3]AUTOMATIC FIRE DETECTION: A SURVEY FROM WIRELESS SENSOR NETWORK PERSPECTIVE Majid Bahrepour, Nirvana Meratnia, Paul Havinga Pervasive Systems Group, University of Twente:-

Automatic fire detection is important for early detection and promptly extinguishing fire. There are ample studies investigating the best sensor combinations and appropriate techniques for early fire detection. In the previous studies fire detection has either been considered as an application of a certain field (e.g., event detection for wireless sensor networks) or the main concern for which techniques have been specifically designed (e.g., fire detection using remote sensing techniques). These different approaches stem from different backgrounds of researchers dealing with fire, such as computer science, geography and earth observation, and fire safety. In this report we survey previous studies from three perspectives: (1) fire detection techniques for residential areas, (2) fire detection techniques for forests, and (3) contributions of sensor networks to early fire detection

There are many concerns in automatic fire detection, of which the most important ones are about different sensor combinations and appropriate techniques for quick and noise-tolerant fire detection. Researchers have been studying fires taking place in various places such as residential area (Milke

and McAvoy 1995), forest (Yu, Wang et al. 2005; Bagheri 2007) and mines (Tan, Wang et al. 2007) to find some solutions for fire monitoring.

III. PROBLEM STATEMENT

1. Due to use of R.F. transmitter / receiver pair, communication between nodes is only unidirectional.
2. Due to use of microcontroller limitations in use of multiple nodes.
3. Range limitation in fire detection to use of fire detector
4. Need of repeaters for long range.

IV. METHODOLOGY

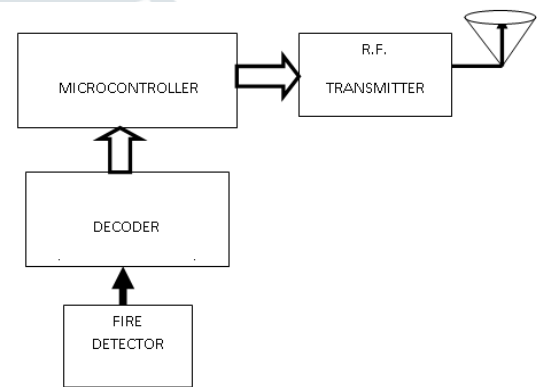

Fig. 4.1 FIRST & SECOND NODE:

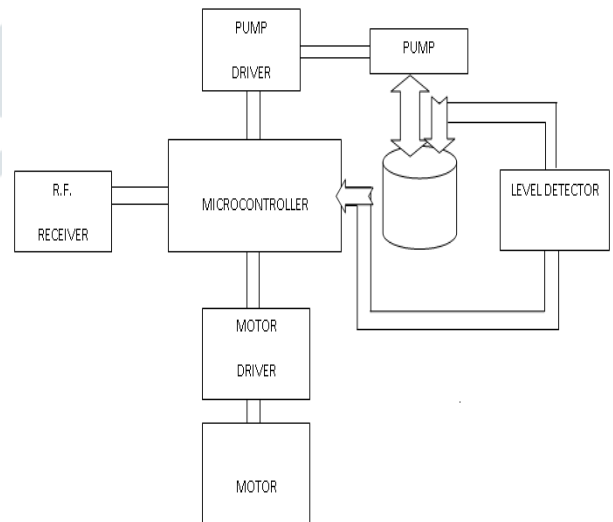

Fig. 4.2 THIRD & FOURTH NODE:

V. Conclusion and Future Scope

An automatic fire alarm system based on wireless sensor networks is designed and developed with emphasis on the network architecture and communication protocol. Prototype system tests show that the system provides early extinguishing of a fire disaster so that damages will be reduced effectively. We must pre-arrange the installing location of each detector in this system due to localization mechanism is not considered. In order to reduce the installation workload and make the system more convenient, automatic localization mechanism is the focus of our future work.

VI. REFERENCES

- [1] M. Tubaishat and S. Madria, Sensor Networks: An Overview, IEEE Potentials, 2003, 22(2):20-23.
- [2] Osterlind, F.; Pramsten, E.; Roberthson, D.; Eriksson, J.; Finne, N.; Voigt, T. Integrating building automation systems and wireless sensor networks. Proceedings of Emerging Technologies and Factory Automation, 2007. 1376-1379.
- [3] Faouzi Derbel. Reliable wireless communication for fire detection systems in commercial and residential areas. Proceedings of Wireless Communications and Networking, 2003. 654-659.
- [4] Kewei Sha, Weisong Shi, Watkins, O. Wayne State Univ., Detroit, MI; Using Wireless Sensor Networks for Fire Rescue Applications: Requirements and Challenges, IEEE International Conference on Electro/information Technology, 2006. 239-244.
- [5] Yeon-sup Lim, Sangsoon Lim, Jaehyuk Choi, et.al. A Fire Detection and Rescue Support Framework with Wireless Sensor Networks. Proceedings of International Conference on Convergence Information Technology, 2007. 135-138.
- [6] Byungrak Son, Yong-sork Her, and Jung-Gyu Kim. A Design and Implementation of Forest-Fires Surveillance System based on Wireless Sensor Networks for South Korea Mountains. International Journal of Computer Science and Network Security. 2006, 6(9B):124-130.